

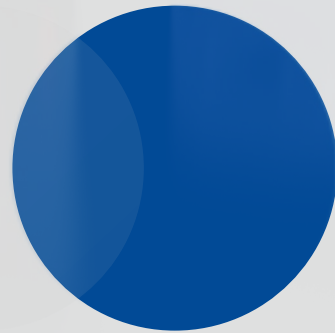

Leadshine

Stock Code: 002979

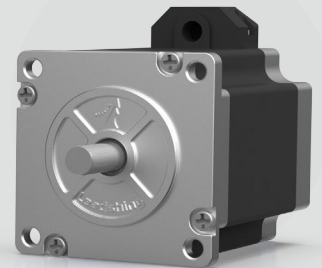
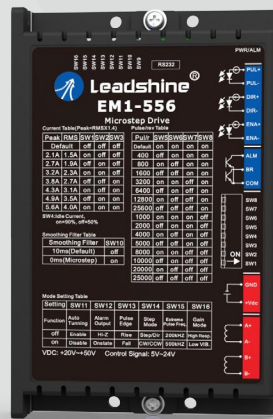
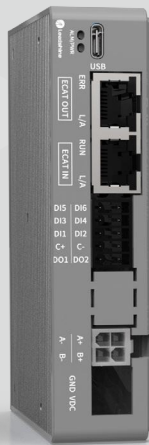
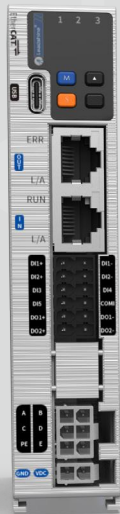

Stepper Products

Product Catalogue

www.leadshine.com

Reliable Motion Control Partner

Contents

- **Page Index** 01-19
 - Company Profile
 - Product System
 - Product Quick Selection
 - Typical Industry Applications
 - Product Overview
- **Digital Stepper Motors and Drives** 20-63
 - Part Numbers
 - Fieldbus Stepper Drives
 - 2EM3EIP / 2EM3E Dual-axis Series 21
 - EM3E Series 25
 - EM2RS Series 29
 - Pulse Control Stepper Drives
 - EM-S/DM-E Series 31
 - EM1 Series 37
 - CM Series Stepper Motors 41
 - 5-phase Stepper Drives 53
- **Closed Loop Stepper Motors and Drives** 64-86
 - Part Numbers
 - Fieldbus Closed Loop Stepper Drives
 - 2CS3EIP / 2CS3E Dual-axis Series 65
 - CS3E Series 69
 - CS2RS Series 73
 - Pulse Control Closed Loop Stepper Drives
 - CS1/CS Series 75
 - CS-M Series Closed Loop Stepper Motors 79
- **Integrated Stepper Motors** 87-90
 - Integrated Stepper Motors
- **Other Products** 91-92
 - LSP Series Power Supplies
 - PLF Series Gearboxes



Headquarters in Shenzhen



Shanghai Intelligent Industry Park



Production base in Shenzhen

- **Founded in 1997**
- **Public Listed Company in China (002979.SZ)**
- **Dedication in Motion Control**
Stepper/Servo systems, Motion Controllers, PLC
Control systems, I/O Modules, Encoders
- **A leading supplier of motion control products and solutions in the world**
- **Customer Oriented, Technology Oriented, Forever Improving, Sharing of Success**

25+ Experience 400+ R&D Engineers 5 Subsidiaries 60+ Countries Clients 10000+ Global Partners 30million+ Installed Axes

Leadshine Motion Control Total Product System

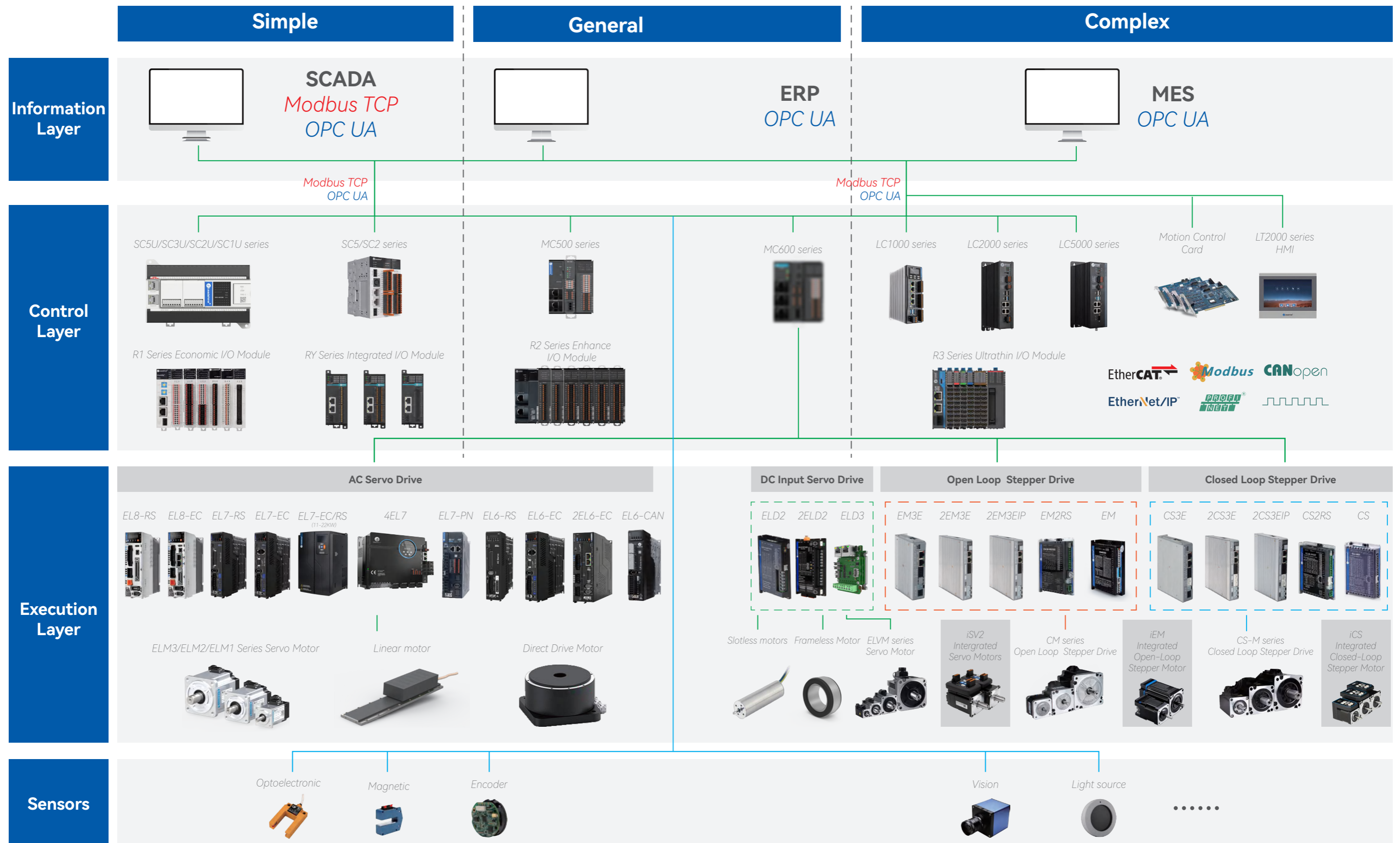

Leadshine Stepper Systems Quick Selection

Stepper Motors

Below matched drive is default Pulse & Direction type, other control types of drive also can be matched;

3-phase stepper motors still keep selling 3S series, others recommend CM series;

Contact Leadshine for other customized model such as inch shaft diameters, modified cable, etc.

Phase/ Series	Frame Size	Length (mm)	Model	Rate Current (A)	Holding Torque (N.m)	Matched Drives	Remark	
2- Phase/CM	NEMA 8	33	20CM003	0.6	0.03	EM415S		
		45	20CM005	0.6	0.05	EM415S		
	NEMA 11	32	20CM006	1.2	0.06	EM415S		
		41	20CM0010	1.2	0.1	EM415S		
		51	20CM0013	1.2	0.13	EM415S		
	NEMA 14	31	35CM015	2.0	0.15	EM422S		
		47	35CM04	2.0	0.4	EM422S		
	NEMA 17	33	42CM02-1A	1.0	0.2	EM415S		
			42CM02	1.5	0.2	EM422S		
		40	42CM04-1A	1.0	0.4	EM415S		
			42CM04	1.5	0.4	EM422S		
		47	42CM06-1A	1.5	0.6	EM422S		
			42CM06	2.5	0.6	EM422S/EM542S	Performance in high-speed	
			42CM06-SZ	2.5	0.8	EM422S/EM542S	Motor with dual shaft	
		60	42CM08-1A	1.5	0.8	EM422S		
			42CM08	2.5	0.8	EM422S/EM542S	Performance in high-speed	
			42CM08-SZ	2.5	0.8	EM422S/EM542S	Motor with dual shaft	
		NEMA 23	41	57CM06	3.0	0.6	EM542S	
				57CM13-3A	3.0	1.3	EM542S	
	56		57CM13	4.0	1.3	EM556S	Performance in high-speed	
			57CM13-SZ	4.0	1.3	EM556S	Motor with dual shaft	
	96		57CM13-BZ	4.0	1.3	EM556S	Motor with brake	
	65		57CM13-FS	4.0	1.3	EM556S	IP65 waterproof	
	76		57CM23-3A	3.0	2.3	EM542S		
			57CM23-4A	4.0	2.3	EM556S		
			57CM23	5.0	2.3	EM556S/EM870S	Performance in high-speed	
	NEMA 23		57CM23-SZ	57CM23-SZ	5.0	2.3	EM556S/EM870S	Motor with dual shaft
		116		57CM23-BZ	5.0	2.3	EM556S/EM870S	Motor with brake
		90	57CM23-FS	5.0	2.3	EM556S/EM870S	Motor with waterproof	
		84	57CM26-4A	4.0	2.6	EM556S		
			57CM26	5.0	2.6	EM556S/EM870S	Performance in high-speed	
		57CM26-SZ	57CM26-SZ	5.0	2.6	EM556S/EM870S	Motor with dual shaft	
			67	D57CM21-4A	4.0	2.1	EM556S	
		D57CM21		5.0	2.1	EM556S/EM870S	Performance in high-speed	
		D57CM21-SZ		5.0	2.1	EM556S/EM870S	Motor with dual shaft	
		88	D57CM31-4A	4.0	3.1	EM556S		
	D57CM31		5.0	3.1	EM556S/EM870S	Performance in high-speed		
	D57CM31-SZ	5.0	3.1	EM556S/EM870S	Motor with dual shaft			

Phase/ Series	Frame Size	Length (mm)	Model	Rate Current (A)	Holding Torque (N.m)	Matched Drives	Remark	
2-Phase/CM	NEMA 24	67	60CM22X	5.0	2.2	EM556S/EM870S	Motor with dual shaft	
			60CM22X-SZ	5.0	2.2	EM556S/EM870S	Motor with brake	
		110	60CM35X-FS	5.0	2.2	EM556S/EM870S		
		85	60CM30X	5.0	3.0	EM556S/EM870S		
			60CM30X-SZ	5.0	3.0	EM556S/EM870S	Motor with dual shaft	
		124	60CM30X-BZ	5.0	3.0	EM556S/EM870S	Motor with brake	
	NEMA 34	65	86CM35	4.0	3.5	EM882S		
			86CM45B	6.0	4.5	EM882S		
		80	86CM45B-I14	6.0	4.5	EM882S		
			86CM45-SZ	6.0	4.5	EM882S	Motor with dual shaft	
		114	86CM45-BZ	6.0	4.5	EM882S	Motor with brake	
		90	86CM45-FS	6.0	4.5	EM882S	Motor with waterproof	
		98	86CM80	6.0	8.0	EM882S		
			86CM85B	6.0	8.5	EM882S		
		118	86CM85B-I14	6.0	8.5	EM882S		
			86CM85-SZ	6.0	8.5	EM882S	Motor with dual shaft	
		152	86CM85-BZ	6.0	8.5	EM882S	Motor with brake	
		130	86CM85-FS	6.0	8.5	EM882S	Motor with waterproof	
		129	86CM120	6.0	12	EM882S/DM1182		
		NEMA 23	115	110CM12	3.0	0.6	DM2282	
	150		110CM20	3.0	1.3	DM2282		
	201		110CM28	4.0	1.3	DM2282		
	NEMA 51	283	130HS45	4.0	1.3	DM2282		
	3-Phase/3S	NEMA 23	50	573S09	3.5	0.9	3DM580S	
			76	573S15	5.8	1.5	3DM580S	
			80	573S20-LS	5.8	1.5	3DM580S	
		NEMA 34	71	863S22	5.0	2.2	3DM883	
			103	863S42	5.0	4.2	3DM883	
			135	863S68H	2.3	6.8	3DM2283	

Phase/ Series	Frame Size	Length (mm)	Model	Rate Current (A)	Holding Torque (N.m)	Matched Drives	Remark	
2-Phase/CM	NEMA 11	51	28CM013-ZK	1.2	0.13	EM415S	Hollow shaft	
		40	42CM04-ZK	2.5	0.4	EM422S	Hollow shaft	
		79	42CM06-BZ	2.0	0.6	EM422S	Brake	
	NEMA 17	88	42CM06-RD05	2.5	0.6	EM422S/EM542S	Gearbox	
		88	42CM06-RD10	2.5	-	EM422S/EM542S	Gearbox	
		95	42CM06-RD20	2.5	-	EM422S/EM542S	Gearbox	
		92	42CM08-BZ	2.0	0.8	EM422S/EM542S	Brake	
		101	42CM08-RD05	2.5	-	EM422S/EM542S	Gearbox	
		101	42CM08-RD10	2.5	-	EM422S/EM542S	Gearbox	
		108	42CM08-RD20	2.5	-	EM422S/EM542S	Gearbox	
		60	42CM08-SZ-ZK	2.5	0.8	EM422S/EM542S	Hollow shaft	
		NEMA 23	55	57CM12C-3A-CZ	3.0	1.2	EM542S	Plug-in terminals
			55	57CM12C-ZK	4.0	1.2	EM542S/EM556S	Hollow shaft
	110		57CM12C-RD05	4.0	-	EM542S/EM556S	Gearbox	
	110		57CM12C-RD10	4.0	-	EM542S/EM556S	Gearbox	
	76		57CM22C-4A-I6-CZ	4.0	2.2	EM556S	Plug-in terminals	
	131		57CM22C-RD05	5.0	-	EM556S	Gearbox	
	NEMA 34	131	57CM22C-RD10	5.0	-	EM556S	Gearbox	
		98	86CM80-ZK	6.0	8.0	EM556S	Hollow shaft	

Close Loop Stepper Drives

Series	Model	Matched Motor Series	Command Source					Electrical Parameters			Motion Function Features					I/O		Others			
			EtherNet/IP	EtherCAT	RS485 Modbus	Pul&Dir	CW&CCW	Power Voltage	Output Current	Logical Voltage	Alarm Output	Brake Output	Self Test	Anti-resonance	Auto-tuning Disable	Digital Input	Digital Output	Mechanical Size (mm)	Tuning Cable	Tuning Software	
2EM3EIP	2EM3EIP-522	CM Series	√					20-50VDC	0.5-2.2A	12-24V		√	√	√	√	√	2*4	2*2	155*116.5*28	CABLE-USB1M5	Motion Studio
	2EM3EIP-556		√					20-50VDC	1.0-5.6A	12-24V		√	√	√	√	√	2*4	2*2	155*116.5*28		
	2EM3EIP-870		√					20-80VDC	1.0-7.0A	12-24V		√	√	√	√	√	2*4	2*2	155*116.5*28		
2EM3E	2EM3E-522			√				20-50VDC	0.5-2.2A	12-24V		√	√	√	√	√	2*4	2*2	155*116.5*28		
	2EM3E-556			√				20-50VDC	1.0-5.6A	12-24V		√	√	√	√	√	2*4	2*2	155*116.5*28		
	2EM3E-870			√				20-80VDC	1.0-7.0A	12-24V		√	√	√	√	√	2*4	2*2	155*116.5*28		
EM3E	EM3E-522B			√				20-50VDC	0.3-2.2A	12-24V		√	√	√	√	√	6	2	118*90*28	CABLE-TYPEC2M0	
	EM3E-556B			√				20-50VDC	1.0-5.6A	12-24V		√	√	√	√	√	6	2	118*90*28		
	EM3E-570B			√				20-50VDC	1.0-7.0A	12-24V		√	√	√	√	√	6	2	118*90*28		
	EM3E-A882			√				18-80VAC 30-110VDC	2.1-8.2A	12-24V		√	√		√	√	7	7	151*113*40	CABLE-USB1M5	Standard ProTuner
EM2RS	EM2RS-522				√			20-50VDC	0.3-2.2A	12-24V		√	√		√	√	7	3	118*79.5*25.5		Motion Studio
	EM2RS-556				√			20-50VDC	0.5-5.6A	12-24V		√	√		√	√	7	3	118*79.5*25.5		
	EM2RS-870				√			20-80VDC	0.5-7.0A	12-24V		√	√		√	√	7	3	118*79.5*25.5		
	EM2RS-A882				√			18-80VAC 30-110VDC	0.5-8.2A	12-24V		√	√		√	√	7	3	151*97*53		
EM-S	EM415S (V2.0)					√	√	12-40VDC	0.3-1.5A	5V		√		√	√	√	3	1	86*55*20	CABLE-PC-1	Standard ProTuner
	EM422S (V2.0)					√	√	12-40VDC	0.3-2.2A	5V		√		√	√	√	3	1	86*55*20		
	EM532MINI					√		18-50VDC	0.3-3.2A	5V		√		√		√	3	1	62*50*26		
	EM542S (V3.0)					√	√	20-50VDC	0.5-4.2A	5/24V		√	√	√	√	√	3	2	118*75.5*25.5		
	EM556S (V3.0)				√	√	20-50VDC	0.5-5.6A	5/24V		√	√	√	√	√	3	2	118*75.5*34			
	EM870S (V3.0)				√	√	20-80VDC	0.5-7.0A	5/24V		√	√	√	√	√	3	2	118*75.5*34			
	EM882S				√	√	20-80VDC	0.5-8.2A	5V		√		√	√	√	3	1	151*97*48	CABLE-PC		
EM1	EM1-422				√	√	20-36VDC	0.3-2.2A	5~24V		√	√	√	√	√	3	2	86*55.5*20.5	CABLE-PC-1	Motion Studio	
	EM1-432				√	√	20-36VDC	0.3-3.2A	5~24V		√	√	√	√	√	3	2	86*55.5*20.5			
	EM1-542				√	√	24-50VDC	0.5-4.2A	5~24V		√	√	√	√	√	3	2	118*75.5*25.5			
	EM1-556				√	√	24-50VDC	0.5-5.6A	5~24V		√	√	√	√	√	3	2	118*75.5*34			
	EM1-870				√	√	24-80VDC	0.5--7.0A	5~24V		√	√	√	√	√	3	2	118*75.5*34			
	EM1-882AC				√	√	20-70VAC 30-100VDC	0.5-8.2A	5~24V		√	√	√	√	√	3	2	151*97*52			
DM-E	DM322E				√		12-30VDC	0.3-2.2A	5V				√			3	0	86*55*20	/		
	DM332E				√		12-30VDC	1.0-3.2A	5V				√			3	0	86*55*20	/		
	DM542E (V3.0)				√		20-50VDC	1.0-4.2A	5/24V		√		√			3	0	118*75.5*25.5	CABLE-PC-1	Standard ProTuner	
	DM556E (V3.0)				√		20-50VDC	1.7-5.6A	5/24V		√		√			3	0	118*75.5*34	CABLE-PC-1	Standard ProTuner	
	DM860E				√	√	20-80VDC	2.4-7.2A	5V				√			3	0	151*97*42.5	/		
	DMA860E(V3.0)				√	√	18-80VAC 30-110VDC	2.4-7.2A	5/24V		√	√		√	√	3	2	151*97*57	CABLE-PC-1	Standard ProTuner	
DM (AC input / 3 phase)	DMA860H				√	√	18-80VAC 30-110VDC	2.4-7.2A	5V				√	√		3	0	151*97*53	/		
	DMA882S				√	√	18-80VAC 30-110VDC	0.5-8.2A	5V		√		√	√		3	1	151*97*53	CABLE-PC	Standard ProTuner	
	DM1182	HS&CM Series				√	√	70-130VAC	0.5-8.2A	5V		√		√	√	3	1	200*145*83	CABLE-PC	DMSeries ProTuner	
	DM2282				√	√	180-240VAC	0.5-8.2A	5V		√		√	√		3	1	200*145*83			
	3DM580S	3S Series				√	√	20-50VDC	0.5-8.2A	5/24V		√		√	√		3	1	118*75.5*34	CABLE-PC-1	Standard ProTuner
	3DM883					√	√	20-80VDC	2.2-8.3A	5/24V		√	√	√	√		3	2	151*97*57	CABLE-PC-1	Standard ProTuner
	3DM2283					√	√	180-240VAC	2.2-11.7A	5V		√		√	√		3	1	200*145*83	CABLE-PC	DMSeries ProTuner

Closed Loop Stepper Motors

Below matched drives are Pulse Control type, EtherCAT and Modbus RS485 types are also available;
 3-phase high voltage closed loop stepper motors are ES2-MH series, others are CS-M series;
 Maximum speed up to 3000 rpm, but depends on power voltage, current and load;

Phase/Series	Frame Size	Length (mm)	Model	Holding Torque (N.m)	Matching Drives	Remark
2-phase/CS-M	NEMA 17	56	CS-M21702	0.2	CS-D507E/CS1-D507S	
		63	CS-M21704	0.4	CS-D507E/CS1-D507S	
		70	CS-M21706	0.6	CS-D507E/CS1-D507S	
		83	CS-M21708	0.8	CS-D507E/CS1-D507S	
	NEMA 23	60	CS-M22306	0.6	CS-D507E/CS1-D507S	
		75	CS-M22313	1.3	CS-D507E/CS1-D507S	Replace ES-M22310
		109	CS-M22313B	1.3	CS-D507E/CS1-D507S	Motor with brake
		94	CS-M22313WP	1.3	CS-D507E/CS1-D507S	Motor with waterproof
		95	CS-M22323	2.3	CS-D507E/CS1-D507S	Replace ES-M22320
		131	CS-M22323B	2.3	CS-D507E/CS1-D507S	Motor with brake
		115	CS-M22323WP	2.3	CS-D507E/CS1-D507S	Motor with waterproof
		103	CS-M22326	2.6	CS-D507E/CS1-D507S	
		86	CS-M22321-L	2.1	CS-D507E/CS1-D507S	NEMA23 motor with large body
		105	CS-M22331-L	3.1	CS-D507E/CS1-D507S	NEMA23 motor with large body
	NEMA 24	89	CS-M22422	2.2	CS-D507E/CS1-D507S	
		129	CS-M22422B	2.2	CS-D507E/CS1-D507S	Motor with brake
		113	CS-M22422WP	2.2	CS-D507E/CS1-D507S	Motor with waterproof
		107	CS-M22430	3.0	CS-D507E/CS1-D507S	
		143	CS-M22430B	3.0	CS-D507E/CS1-D507S	Motor with brake
		130	CS-M22430WP	3.0	CS-D507E/CS1-D507S	Motor with waterproof
	NEMA 34	95	CS-M23435	3.5	CS-D1008E	
		109	CS-M23445	4.5	CS-D1008E	
		144	CS-M23445B	4.5	CS-D1008E	Motor with brake
		115	CS-M23445WP	4.5	CS-D1008E	Motor with waterproof
		127	CS-M23480	8.0	CS-D1008E	
		152	CS-M23480B	8.0	CS-D1008E	Motor with brake
		133	CS-M23480WP	8.0	CS-D1008E	Motor with waterproof
		147	CS-M23485	8.5	CS-D1008E	
		182	CS-M23485B	8.5	CS-D1008E	Motor with brake
		153	CS-M23485WP	8.5	CS-D1008E	Motor with waterproof
		158	CS-M234120	12	CS-D1008E	
		193	CS-M234120B	12	CS-D1008E	Motor with brake
164	CS-M234120WP	12	CS-D1008E	Motor with waterproof		

Phase/Series	Frame Size	Length (mm)	Model	Holding Torque (N.m)	Matching Drives	Remark
3-phase/ES2-MH	NEMA 17	157	ES2-MH33480	8.0	ES-DH2306	
		190	ES2-MH33480B	8.0	ES-DH2306	Motor with brake
		162	ES2-MH33480WP	8.0	ES-DH2306	Motor with waterproof
		184	ES2-MH334100	10	ES-DH2306	
	NEMA 23	218	ES2-MH334100B	10	ES-DH2306	Motor with brake
		191	ES2-MH334100WP	10	ES-DH2306	Motor with waterproof
		162	ES2-MH342120	12	ES-DH2306	
		207	ES2-MH342120B	12	ES-DH2306	Motor with brake
		167	ES2-MH342120WP	12	ES-DH2306	Motor with waterproof
		244	ES2-MH342200	20	ES-DH2306	

Phase/Series	Frame Size	Length (mm)	Model	Holding Torque (N.m)	Matching Drives	Remark
2-phase/CS-M	NEMA 8	51	CS-M208003	0.03	CS-D507E	-
	NEMA 11	62	CS-M211013	0.13	CS-D507E	-
	NEMA 17	93	CS-M21704B	0.4	CS-D507E	Brake
		101	CS-M21706B	0.6	CS-D507E	Brake
		113	CS-M21708B	0.8	CS-D507E	Brake
	NEMA 23	96	CS-M22323-S	2.3	CS-D507E	1/4-inch shaft diameter
		104	CS-M22326-S	2.6	CS-D507E	1/4-inch shaft diameter
		105	CS-M22331-L-S	3.1	CS-D507E	3/8-inch shaft diameter
	NEMA 24	107	CS-M22430-I14	3.0	CS-D507E	AC servo flange
		147	CS-M22430B-I14	3.0	CS-D507E	AC servo flange, Brake
	NEMA 34	109	CS-M22445-S	4.5	CS-D1008E	1/2-inch shaft diameter
		127	CS-M23480-S	8.0	CS-D1008E	1/2-inch shaft diameter
		147	CS-M23485-S	8.5	CS-D1008E	1/2-inch shaft diameter

Stepper Drives

Series	Model	Matched Motor Series	Command Source					Electrical Parameters			Motion Function Features						I/O		Encoder Resolution (ppr)	Others		
			EtherNet/IP	EtherCAT	RS485 Modbus	Pul&Dir	CW&CCW	Power Voltage	Output Current	Logical Voltage	Alarm Output	Brake Output	Self Test	Fault Reset	Z Signal	Open/Closed Loop Selection	Digital Input	Digital Output		Mechanical Size (mm)	Tuning Cable	Tuning Software
2CS3EIP	2CS3EIP-D503	CM Series	√					20-50VDC	0.5-2.2A	12-24V		√	√		√	√	√	2*4	2*2	155*116.5*28	CABLE-USB1M5	Motion Studio
	2CS3EIP-D507		√					20-50VDC	1.0-7.0A	12-24V		√	√		√	√	√	2*4	2*2	155*116.5*28		
2CS3E	2CS3E-D503			√				20-50VDC	0.5-2.2A	12-24V		√	√		√	√	√	2*4	2*2	155*116.5*28		
	2CS3E-D507			√				20-50VDC	1.0-7.0A	12-24V		√	√		√	√	√	2*4	2*2	155*116.5*28		
CS3E	CS3E-D503B			√				20-50VDC	0.1-3.0A	12-24V		√	√		√	√	√	6	2	118*90*28	CABLE-TYPEC2M0	
	CS3E-D507B			√				20-50VDC	0.1-7.0A	12-24V		√	√		√	√	√	6	2	118*90*28		
	CS3E-D1008			√				18-80VAC 30-110VDC	0.5-8.0A	12-24V		√	√		√	√	√	7	7	151*113*40	CABLE-MUSB1M5	
CS2RS	CS2RS-D503					√		20-50VDC	0.3-3.0A	12-24V		√	√		√	√	√	7	3	118*79.5*25.5	CABLE-PC-1	
	CS2RS-D507					√		20-50VDC	0.5-7.0A	12-24V		√	√		√	√	√	7	3	118*79.5*25.5		
	CS2RS-D1008					√		18-80VAC 30-110VDC	0.5-8.0A	12-24V		√	√		√	√	√	7	3	151*97*53		
CS1	CS1-D503S					√	√	20-50VDC	0.5-3.0A	5/24V		√	√	√	√	√	√	4	6	118*79.5*25.5		
	CS1-D507S					√	√	20-50VDC	0.5-7.0A	5/24V		√	√	√	√	√	√	4	6	118*79.5*25.5		
	CS1-D728S				√	√	20-72VDC	0.5-8.0A	5/24V		√	√	√	√	√	√	4	6	118*79.5*25.5			
CS	CS-D403				√	√	20-50VDC	0.3-3.0A	5V		√	√		√		√	3	1	116*69.2*26.5	CABLE-PC	ProTuner CS_V3.0	
	CS-D508				√	√	20-50VDC	0.5-7.0A	5V		√	√		√		√	3	1	116*69.2*26.5			
	CS-D808				√	√	20-80VDC	0.5-8.0A	5V		√	√		√		√	3	1	151*97*53			
	CS-D1008				√	√	18-80VAC 30-110VDC	0.5-8.0A	5V		√	√		√		√	3	1	151*97*53			
	CS-D507E				√	√	20-50VDC	0.5-7.0A	5/24V		√	√		√		√	3	2	116*69.2*26.5	CABLE-PC-1		
	CS-D1008E				√	√	18-80VAC 30-110VDC	0.5-8.0A	5/24V		√	√		√		√	3	2	151*97*53			

Integrated Stepper Motors

Series	Model	Frame Size	Motor Type	Length (mm)	Holding Torque (mm)	Control Type				Electrical Parameters			Motion Function Features			I/O		Others	
						RS485 Modbus	Pulse&Dir	CW&CCW		Power Voltage	Output Current	Logical Voltage	Alarm Output	PR Mode	I/O Configurable	Digital Input	Digital Output	Tuning Cable	Tuning Software
iEM	iEM-1703	NEMA17	Open Loop	64	0.3		√			20-36VDC	0.3-3.0A	5V	√			3	1	CABLE-PC-1	Motion Studio
	iEM-1706			72	0.6		√			20-36VDC	0.3-3.0A	5V	√			3	1		
	iEM-1708			85	0.8		√			20-36VDC	0.3-3.0A	5V	√			3	1		
	iEM-RS1706			73	0.6	√				20-36VDC	0.3-3.0A	12-24V	√	√		3	1		
	iEM-RS1708			86	0.8	√				20-36VDC	0.3-3.0A	12-24V	√	√		3	1		
	iEM-2313	NEMA23		75	1.3		√	√		20-50VDC	0.5-6.0A	5V	√			3	1		
	iEM-2323			96	2.3		√	√		20-50VDC	0.5-7.0A	5V	√			3	1		
	iEM-2321-L			89	2.1		√	√		20-50VDC	0.5-7.0A	5V	√			3	1		
	iEM-2331-L			109	3.1		√	√		20-50VDC	0.5-7.0A	5V	√			3	1		
	iEM-RS2313			78	1.3	√				20-50VDC	0.5-6.0A	12-24V	√	√		3	1		
	iEM-RS2323	99		2.3	√				20-50VDC	0.5-7.0A	12-24V	√	√		3	1			
	iEM-2430	NEMA24		109	3.0		√	√		20-50VDC	0.5-7.0A	5V	√			3	1		
	iEM-2435			122	3.5		√	√		20-50VDC	0.5-7.0A	5V	√			3	1		
	iCS	iCS-1703		NEMA17	Closed Loop (14-bit magnetic encoder)	64	0.3		√			20-36VDC	0.3-3.0A	5V	√		√		
iCS-1706		72	0.6				√			20-36VDC	0.3-3.0A	5V	√		√	3	1		
iCS-1708		85	0.8				√			20-36VDC	0.3-3.0A	5V	√		√	3	1		
iCS-RS1706		73	0.6			√				20-36VDC	0.3-3.0A	12/24V	√	√	√	3	1		
iCS-RS1708		86	0.8			√				20-36VDC	0.3-3.0A	12/24V	√	√	√	3	1		
iCS-2313		NEMA23	75	1.3			√	√		20-50VDC	0.5-6.0A	5V	√		√	3	1		
iCS-2323			96	2.3			√	√		20-50VDC	0.5-7.0A	5V	√		√	3	1		
iCS-2321-L			89	2.1			√	√		20-50VDC	0.5-7.0A	5V	√		√	3	1		
iCS-2331-L			109	3.1			√	√		20-50VDC	0.5-7.0A	5V	√		√	3	1		
iCS-RS2313			78	1.3		√				20-50VDC	0.5-7.0A	12/24V	√	√	√	3	1		
iCS-RS2323		99	2.3	√					20-50VDC	0.5-7.0A	12/24V	√	√	√	3	1			
iCS-2430		NEMA24	109	3.0			√	√		20-50VDC	0.5-7.0A	5V	√		√	3	1		
iCS-2435			122	3.5			√	√		20-50VDC	0.5-7.0A	5V	√		√	3	1		

Typical Industry Application

Electronic Manufacturing Equipment

We provide accurate bus-based and intelligent motion control solutions for electronic equipment to help customers improve production efficiency and reduce costs

- Dispensing machine
- SMT
- Screw locking machine
- Wire stripping machine
- Lithium battery equipment



Dispensing machine

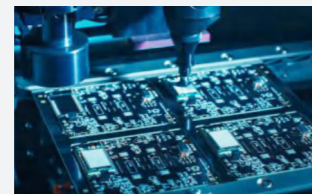

SMT

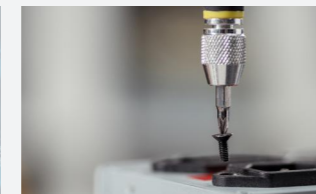

Screw locking machine



Wire stripping machine

Textile and Garment Equipment

We support multi-variety production and high quality demands in the textile and garment industry, contributing to the consistency of quality and high production efficiency of textile and garment.

- Computer cutting plotter
- Template cutting machine
- Garment proofing machines
- Pattern cutting machine
- Vertical cutting machine



Textile Equipment

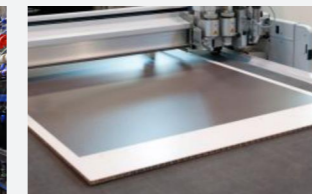

Template cutting machine



Garment proofing machines

Laser Engraving Equipment

For engraving equipment, especially for non-linear multi-dimensional plane processing, we can improve the responsiveness of feedback through large bandwidth response frequency, no horizontal and vertical stripes are produced, the chamfer is more flexible, and the processing surface is smoother.

- Laser cutting machine
- Laser marking machine
- Jade carving machine
- Wood carving machine



Laser cutting machine



Wood carving machine

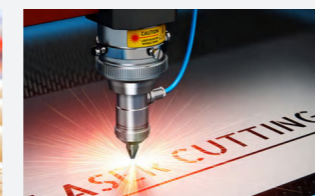

Laser marking machine

Medical and Health Equipment

Excellent low vibration, low noise and low heat generation make the medical equipment run quietly and smoothly.

- Biochemical analyzer
- Peristaltic pump
- Mask machine
- Blood sample analyzer
- Urine analyzer



Blood sample analyzer



Biochemical analyzer

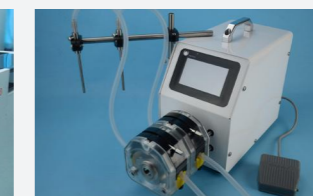

Peristaltic pump



Mask machine

Renewable Energy Equipment

Through the high-speed and high-response servo stepper system to drive silicon wafers, batteries and other automatic production and inspection modules, it contributes to improving the production efficiency of the whole line of new energy equipment and reducing production costs for customers.

- Sorter
- Stack welding machine
- Liquid injection machine



Stack welding machine



Sorter



Liquid injection machine

Product Overview

Fieldbus Stepper Drives

2EM3EIP Series (NEW)
2EM3E Series (NEW)
EM3E Series
EM2RS Series

EtherNet/IP **EtherCAT** **Modbus**

Power Voltage:
20-50VDC, 20-80VDC
30-110VDC or 20-80VAC

Command Source:
EtherCAT, EtherNet/IP, Modbus RTU

Inputs and Outputs:
EM3E-522E/556E/870E: 5 DI, 2 DO
EM3E-A882: 7 DI, 6 DO
2EM3E Series: Dual-axis, 4 DI, 2 DO
2EM3EIP Series: Dual-axis, 4 DI, 2 DO

Pulse Control Stepper Drives

EM Series
DM Series
EM1 Series (NEW)



Power Voltage:
12-40VDC, 20-50VDC, 20-80VDC, 30-110VDC or
20-80VAC, 110VAC+10% 220VAC+10%

Command Source:
EM-S: Pulse&Direction, CW&CCW
DM-E: Pulse&Direction
EM1: Pulse&Direction, CW&CCW

Inputs and Outputs:
DM332E/322E: 3 DI
DM542E/556E: 3 DI, 1 DO
DMA860E: 3 DI, 2 DO
EM1: 3 DI, 2 DO
DM1182/DM2282: 3 DI
3DM580S/883/2283: 3 DI
EM-S: 3 DI, 1 DO

5-phase Stepper Drives

DM5 Series
DM5-EC series (NEW)



EtherCAT

Power Voltage:
24-36VDC
20-50VDC

Command Source:
DM5: Pulse&Direction
DM5-EC: EtherCAT

Inputs and Outputs:
DM5: 4 DI, 3 DO
DM5-EC: 5 DI, 2 DO

Standard Stepper Motors

CM Series
5-phase stepper motor

Frame Size:
From NEMA 08(20mm) to NEMA 51(130mm)
2-phase: 20mm, 28mm, 35mm, 42mm, 57mm, 60mm, 86mm, 110mm, 130mm
3-phase: 57mm, 86mm, 110mm

Options:
Dual shaft
Encoder
Brake
IP65 waterproof
Gearbox

Fieldbus Closed Loop Stepper Drives

2CS3EIP Series (NEW)
2CS3E Series (NEW)
CS3E Series
CS2RS Series

EtherNet/IP **EtherCAT** **Modbus**

Power Voltage:
20-50VDC
30-110VDC or 20-80VAC

Command Source:
EtherCAT, EtherNet/IP, Modbus RTU

Inputs and Outputs:
CS3E-D503/507/1008: 7 DI / 7 DO
CS2RS-D503/507/1008: 7 DI, 3 DO
2CS3E series: Dual-axis, 4 DI, 2 DO
2CS3EIP series: Dual-axis, 4 DI, 2 DO

Pulse Control Closed Loop Stepper Drives

CS1 Series
CS Series



Power Voltage:
20-50VDC
20-72VDC
20-80VAC or 30-110VDC

Command Source:
Pulse&Direction, CW&CCW

Inputs and Outputs:
CS1-D507S: 4 DI, 3 DO encoder outputs
CS1-D728S: 4 DI, 3 DO
CS-D507E: 3 DI, 2 DO
CS-D1008E: 3 DI, 2 DO

Closed Loop Stepper Motors

CS-M Series & ES2-MH Series

Frame Size and Encoder:
20mm: 1000 line
28mm: 1000 line
42mm: 1000/5000 line
57mm: 1000/5000 line
60mm: 1000/5000 line
86mm: 1000/5000 line
110mm: 1000/5000 line

Options:
Brake
IP65 waterproof

Integrated Stepper Motors



Open loop: IEM Series, IEM-RS Series

Closed loop: iCS Series, iCS-RS Series



Power Voltage:

20-36VDC
20-50VDC

Command Source:

iEM/iCS: Pulse&Direction
iEM-RS/iCS-RS: Modbus RS485

Inputs and Outputs:

3 DI, 1 DO

Power Supplies



LSP Series

Power Voltage:

220VAC±10% or 110VAC±10% input
260W: 24VDC output
360W: 24VDC/36VDC/48VDC output
400W: 60VDC output

Gearboxes



PLF Series

Gearboxes:

60mm: 3:1, 5:1, 7:1, 10:1
90mm: 3:1, 5:1, 7:1, 10:1
NEMA 23 and 34
1 to 2 stages
High precision
Low noise

Stepper Drive Part Numbers

EM □□ 5 56 S - □

Series Name	
EM	New Series
DM	Classical Series
3DM	3-phase Drive Series

Control Mode	
3E-	EtherCAT Control
2RS-	RS485 Modbus RTU
Blank	Pulse Control

AC or DC	
Blank	DC
A	AC (except DM1182 and DM2282)

Max Power Voltage	
4	40V
5	50V
8	80V
11	110V±10%
8	120V±10%

Special Control	
IO	5-24V Digital Input Control
IO-24	24V Digital Input Control
V-24	0-10V Analog and 24V Digital Input Control
AI	0-5V Analog Input Control or Pulse Control
500	Max Pulse Frequency 500KHz
CAN	CANopen Control

Grade	
Blank	Standard
E	Economic
S	High Performance

Max Peak Current	
15:1.5A	56:5.6A
22:2.2A	70:7.0A
32:3.2A	82:8.2A
42:4.2A	83:8.3A

Stepper Motor Part Numbers

57 CM 23 - 4A - □□

Series Name			
20	20mm (NEMA 8)	28	28mm (NEMA 11)
35	35mm (NEMA 14)	39	39mm (NEMA 16)
42	42mm (NEMA 17)	57/D57	57mm (NEMA 23)
60	60mm (NEMA 51)	86	86mm (NEMA 34)
110	110mm (NEMA 17)	130	130mm (NEMA 42)

Series Name	
CM	New 2-phase Motor Series
HS	Classical 2-phase Motor Series
3S	3-phase Motor Series

Holding Torque	
013:0.13N.m	30:3.0N.m
02:0.2N.m	45:4.5N.m
06:0.6N.m	80:8.0N.m
08:0.8N.m	85:8.5N.m
13:1.3N.m	120:12N.m
23:2.3N.m	
For NEMA 42&51	
12:12N.m	28:28N.m
20:20N.m	45:45N.m
27:27N.m	

Rated Current	
Blank	Standard Rated Current
1A	1.5A
3A	3.0A
4A	4.0A

Customized	
Customized Model	

Standard Customized Specification	
Blank	Standard
BZ	Brake
SZ	Dual Shaft
FS	Waterproof (Rate IP65)
I	Shaft Diameter
K	NEMA23 Motor Shaft with Key
S30	Shaft Length 30mm
CZ	Plug-in Type Motor
ZK	Hollow Shaft Motor
Rd05	Integrated 1:5 Gearbox
Rd10	Integrated 1:10 Gearbox
Rd20	Integrated 1:20 Gearbox



2EM3EIP Series \ 2EM3E Series

Fieldbus Stepper Drives

- Support EtherCAT(EtherNet/IP) fieldbus
- Matching most of master controller

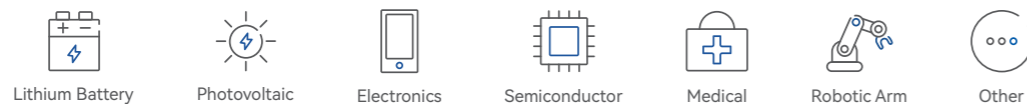

Overview

○ EtherCAT(EtherNet/IP) Communication

- Support EtherNet/IP(EtherCAT) communication.
- Support great majority of master station such as Beckhoff, Omron, KEYENCE, Panasonic etc.
- Support position, velocity, and homing control mode.

○ More Efficient by Dual-axis Control

- One drive controls two axes via one IP address, highly reduce communication load rate.
- Two axes are independently controlled.

○ STO Optional

- Safe torque off (STO) ensure the safety system.

○ Saving Cost

- One dual-axis drive is more economic than two single-axis drives.

○ Saving Mounting Space

- 10% thickness reducing compared to one single-axis drive.
- 50% at least mounting space saving compared to two single-axis drives.

Specifications

Models	Operating Voltage	Output Current (A)	Matching Motor	Weight (kg)	Dimension (mm)
2EM3EIP-522	20-50VDC	0.5-2.2	NEMA8/11/14/17	0.4	155*116.5*28
2EM3EIP-556	20-50VDC	1.0-5.6	NEMA17/23/24	0.4	155*116.5*28
2EM3EIP-870	20-80VDC	1.0-7.0	NEMA23/24/34	0.4	155*116.5*28
2EM3E-522	20-50VDC	0.5-2.2	NEMA8/11/14/17	0.4	155*116.5*28
2EM3E-556	20-50VDC	1.0-5.6	NEMA17/23/24	0.4	155*116.5*28
2EM3E-870	20-80VDC	1.0-7.0	NEMA23/24/34	0.4	155*116.5*28
Termination Resistor	The last node needs to add the terminal resistance generally				
Tuning cable	CABLE-USB1M5				
CABLE-TX*M*-BUS	Network Cable: 0.1m, 0.2m, 0.3m, 0.4m, 1m, 1.5m, 2m, 3m,5m,7m, 10m,15m, 20m				

2EM3EIP Series \ 2EM3E Series

Unit: mm

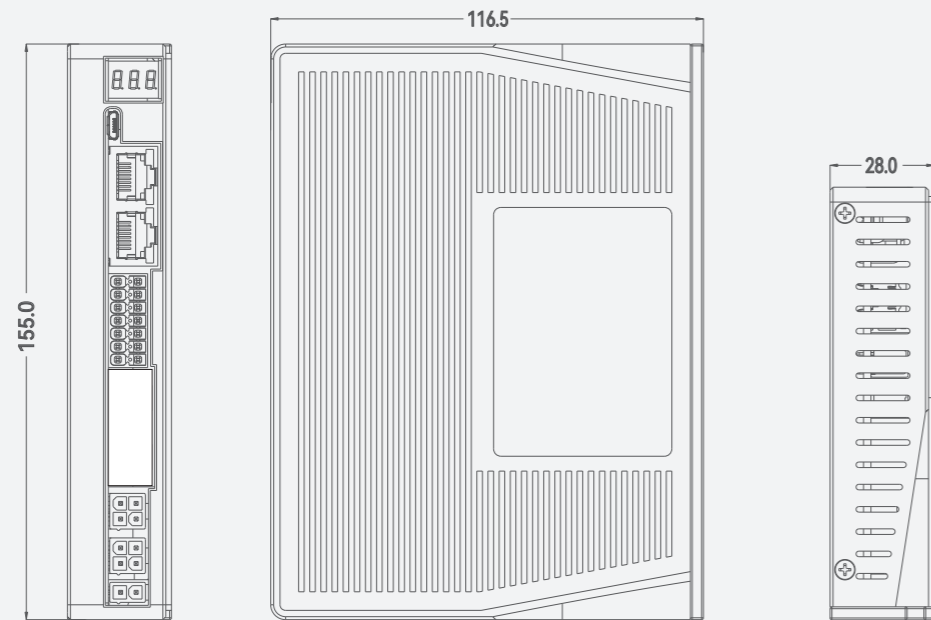

Drive Wiring Diagram

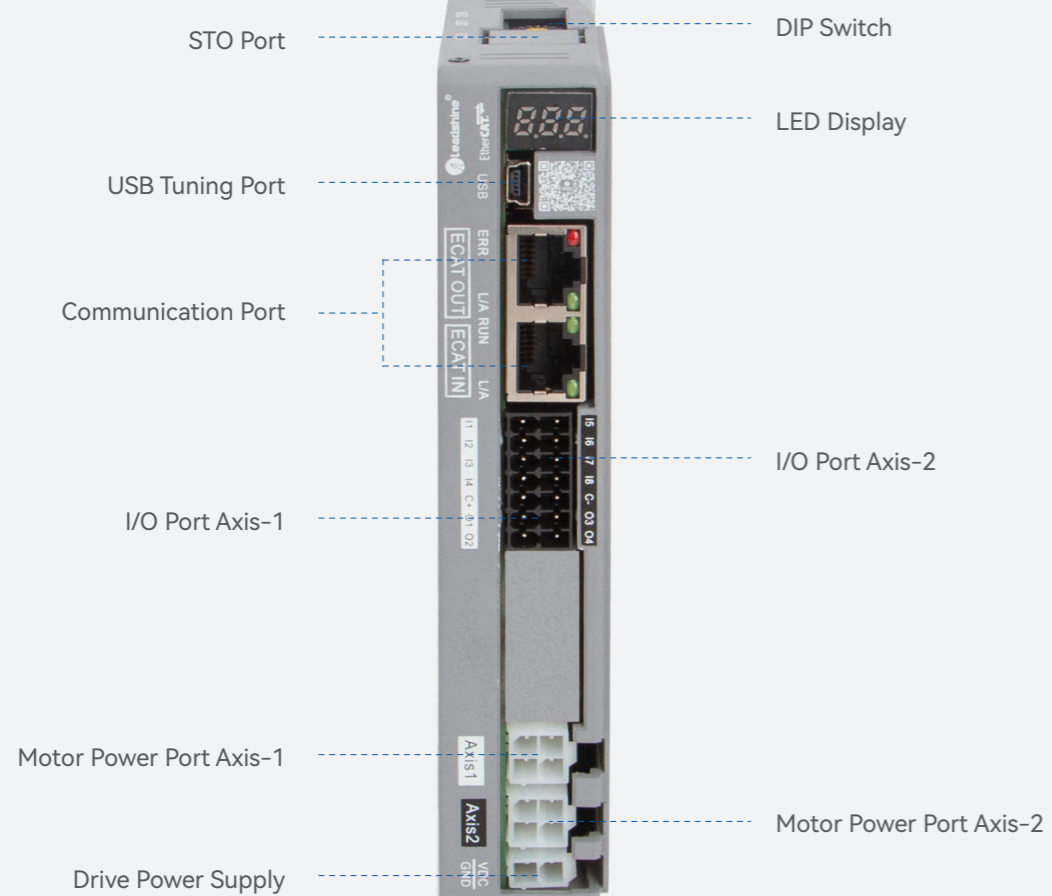
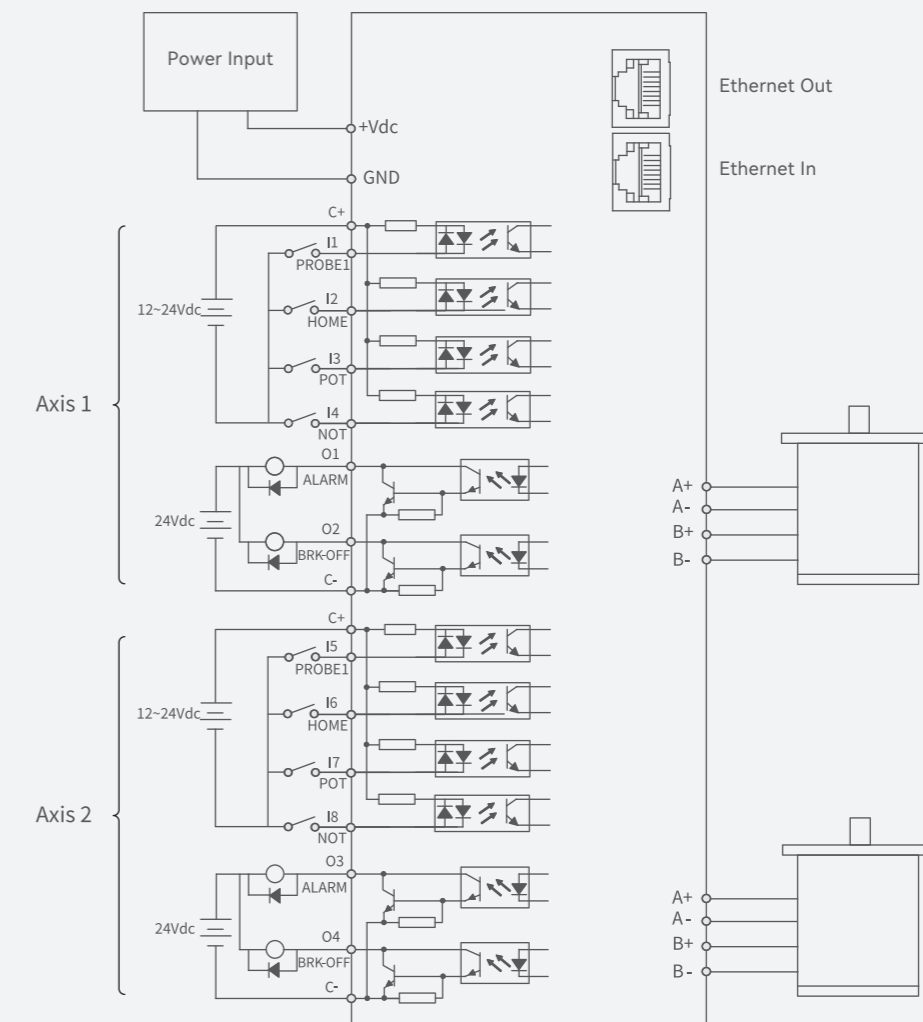



EM3E Series

Fieldbus Stepper Drives

EM3E series drives support operating modes: Profile Position (PP), Profile Velocity (PV), Homing(HM) , Cyclic Synchronous Position (CSP). The products can be matched with most of EtherCAT controller/PLC such as Beckhoff, Omron, Trio, etc.

- Support CoE control and CiA 402 protocol
- Matching most of master controller
- Conformance tested by ETG

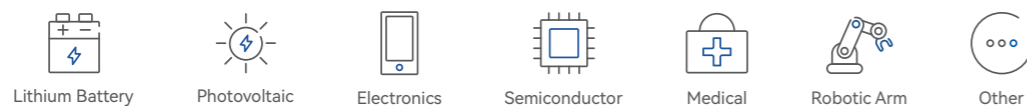

Overview

- Thickness reduce to 28mm, more benefit for mounting.
- Friendly type-C tuning port
Improve network anti-interference ability.
- Low noise and vibration, smooth motion.
- EM3E support standard EtherCAT with operation modes of PP, PV, CSP, HM.
- Configurable I/O features: limit switch, alarm, brake, etc.
- Optically coupled isolated input, strong anti-interference ability.
- Auto-tuning of motor parameters.
- Protections for over voltage, over current etc.

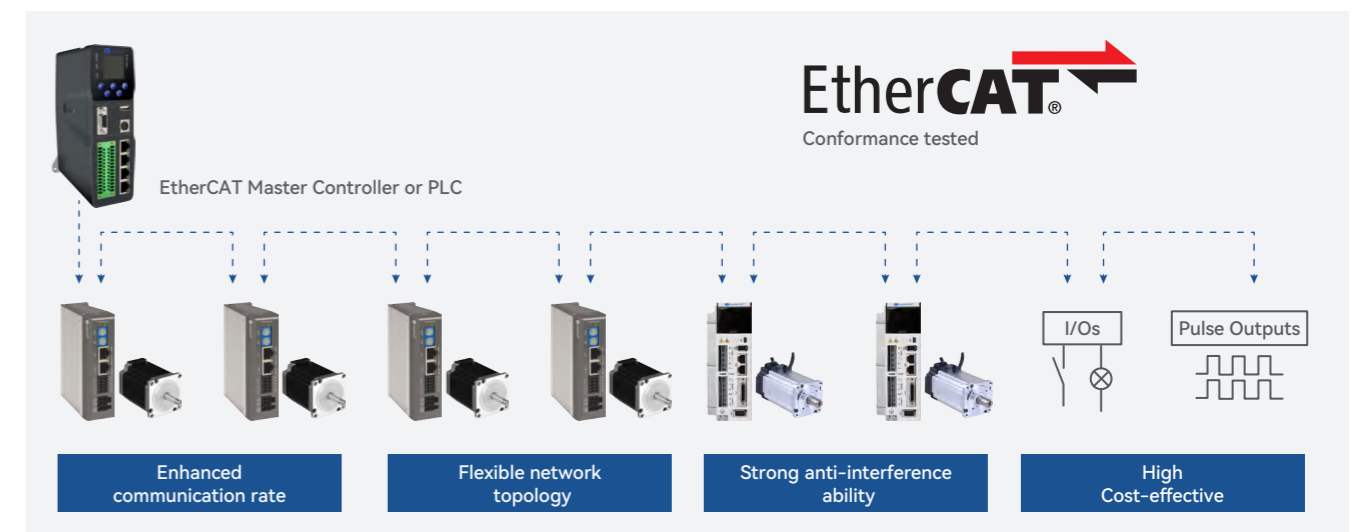

Specifications

Models	Operating Voltage	Output Current (A)	Matching Motor	Weight (kg)	Dimension (mm)
EM3E-522B	20-50VDC	0.3-2.2A	NEMA8/11/14/17	0.57	118*90*28
EM3E-556B	20-50VDC	1.0-5.6A	NEMA17/23/24	0.57	118*90*28
EM3E-570B	20-50VDC	1.0-7.0A	NEMA23/24/34	0.57	118*90*28
EM3E-A882	20-80VAC or 30-100VDC	2.1-8.0A	NEMA34	0.85	151*113*20
Tuning Cable	CABLE-TYPEC2M0				
CABLE-TX*M*-BUS	Network Cable: 0.1m, 0.2m, 0.3m, 0.4m, 1m, 1.5m, 2m, 3m,5m,7m, 10m,15m, 20m				

EM3E Series

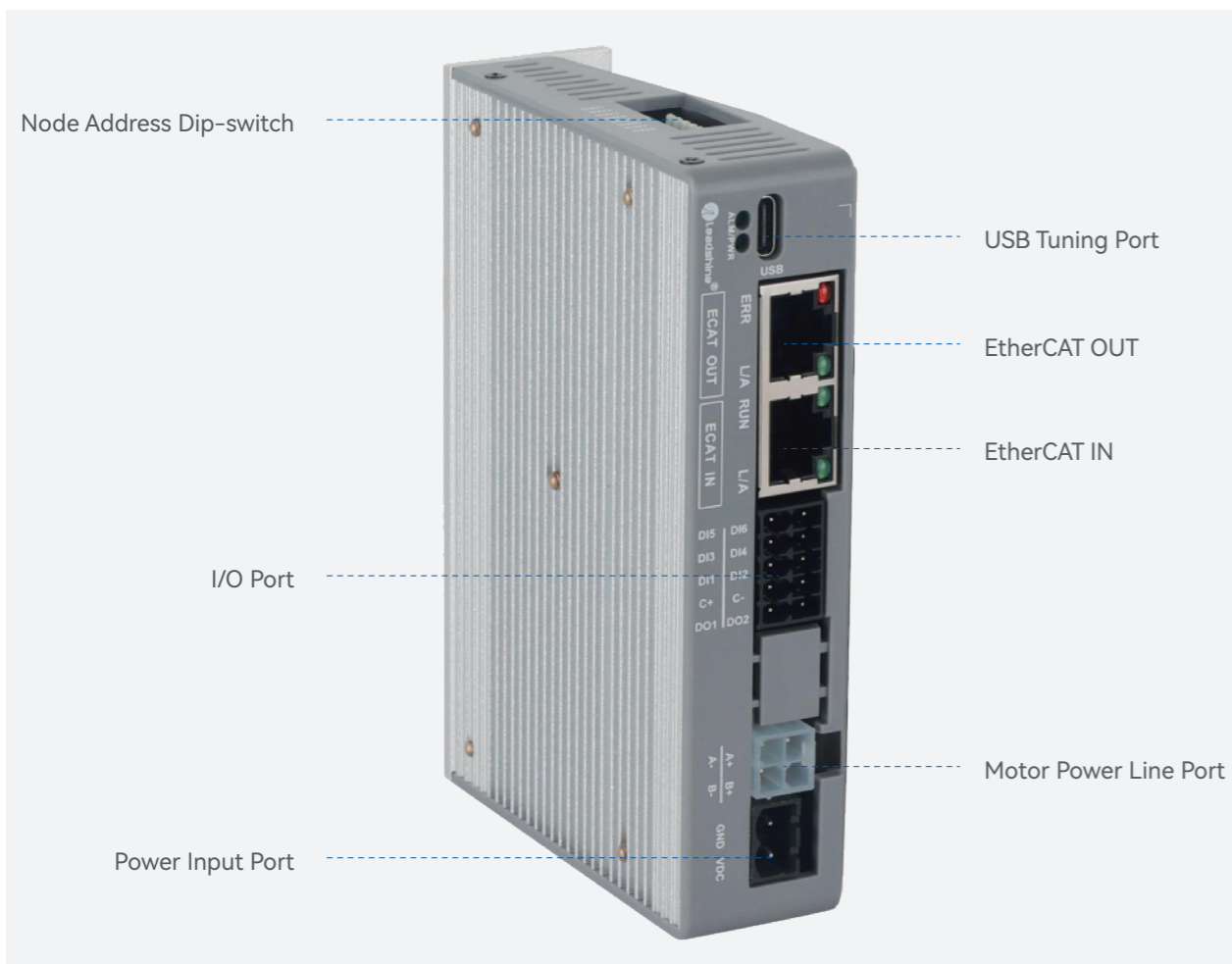
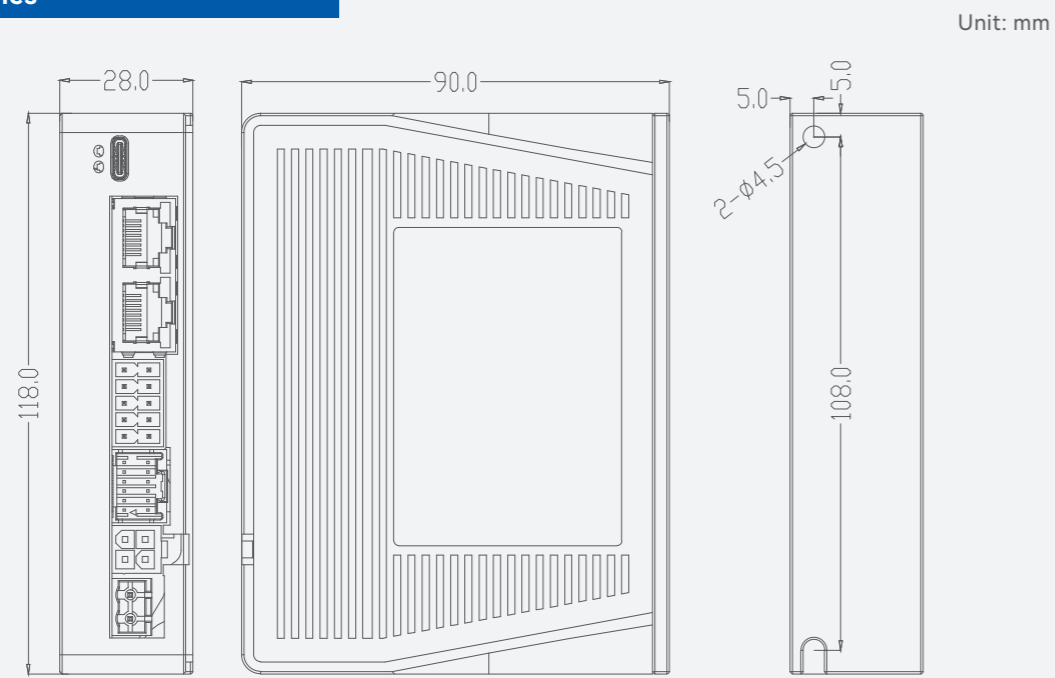

Drive Wiring Diagram

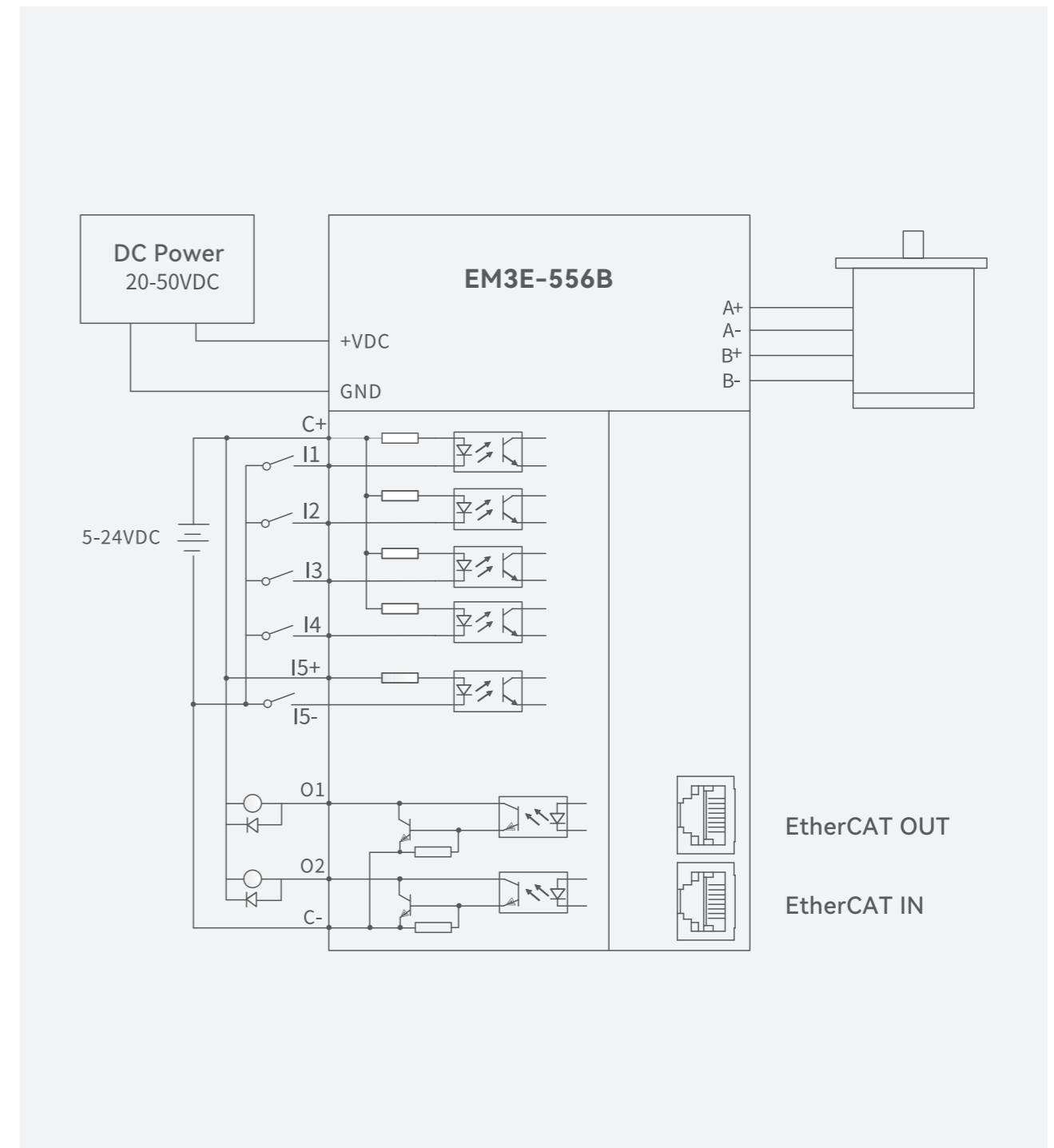



EM2RS Series

Fieldbus Stepper Drives

- Standard Isolated RS485 Modbus
- Smooth motion & Anti-resonance

- Built-in Uni-axial Control Instruction
- HMI, PLC or External I/O start motion

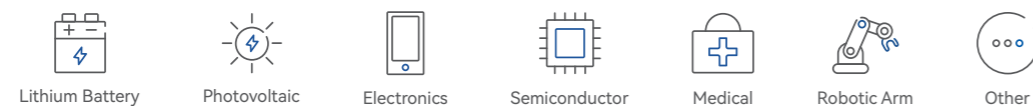

Overview

- **7 Programmable Inputs**
 - Limit + / - or Origin inputs
 - Quick stop, Alarm reset and Enable inputs
 - JOG + / - or Position Table inputs
- **3 Programmable Outputs**
 - Alarm, Brake outputs
 - Homing / Instruction / Path complete
- **Modes of Operation**
 - Velocity
 - Position
 - Homing
- **Support Functions**
 - Teaching
 - Interrupt
 - Skip, Suspend, Circulate motion
- **PC Software for Easy Setup, Fine Tune, Matching Motors**
 - NEMA8, 11,17, 23, 24, 34
 - Standard, dual shaft, brake, waterproof

Support RS485 communication

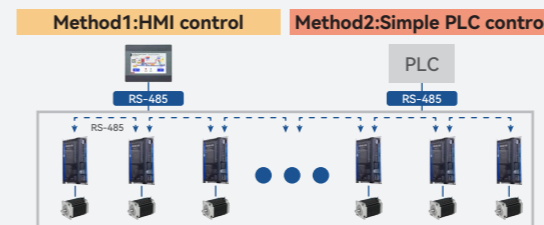

Built-in uni-axial control instruction

- Programmable 16-segment position table, support positioning / homing / limit / quick stop / JOG...

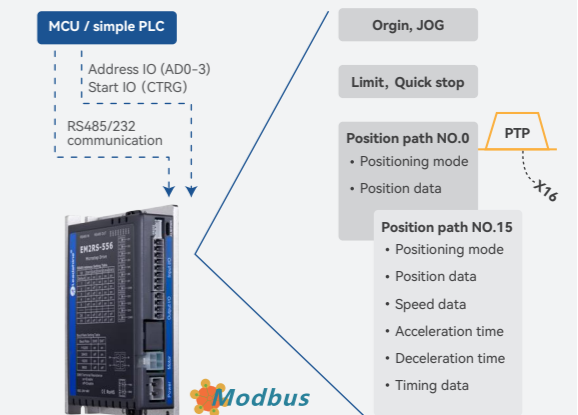

Instruction smoothing

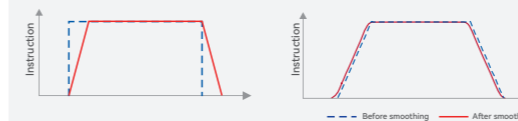

Figure A: When the controller sends a step signal of instruction, the stepper drive automatically smooths to a trapezoidal signal.

Figure B: When the controller sends a trapezoidal signal of instruction, the stepper drive automatically smooths to an s-shaped signal.

Specifications

Models	Operating Voltage	Output Current (A)	Matching Motor	Weight (kg)	Dimension (mm)
EM2RS-522	20-50VDC	0.3-2.2	NEMA8/11/14/17	0.55	151*97*53
EM2RS-556	20-50VDC	0.5-5.6	NEMA17/23/24	0.55	118*79.5*25.5
EM2RS-870	20-80VDC	0.5-7.0	NEMA23/24/34	0.55	118*79.5*25.5
EM2RS-A882	20-80VAC or 30-100VDC	0.5-8.0	NEMA24/34	0.57	155*116.5*28
Tuning cable	CABLE-PC-1				
CABLE-TX*M*-BUS	Network Cable: 0.1m, 0.2m, 0.3m, 0.4m, 1m, 1.5m, 2m, 3m,5m,7m, 10m,15m, 20m				



EM-S Enhanced Version DM-E Cost-effective Version

Pulse Control Stepper Drives

EM-S Series Enhanced Performance

EM-S series stepper drives from Leadshine offer superior performance and exceptional high reliability. Based on Leadshine's 20+ years' experience in stepper motor control, they adopt the latest control technology and are ideal for modern machine manufactures. Not only inheriting features of smooth motion, low noise, low heating, etc. from past Leadshine stepper drives, they also offer new functions and features such as improved torque in all speed ranges, fault output, brake control, pulse command smoothing... They are capable of powering wide range of stepper motors of NEMA 8, 11, 15, 17, 23, 34, and 42.

Overview

- Torque increased by 10%-25%
- Step & DIR or CW & CCW control
- Alarm and Brake outputs
- 200kHz (500kHz optional) max frequency
- 5V or 24V signal voltage optional
- Soft-start with no "jump"
- Over-voltage, over-current

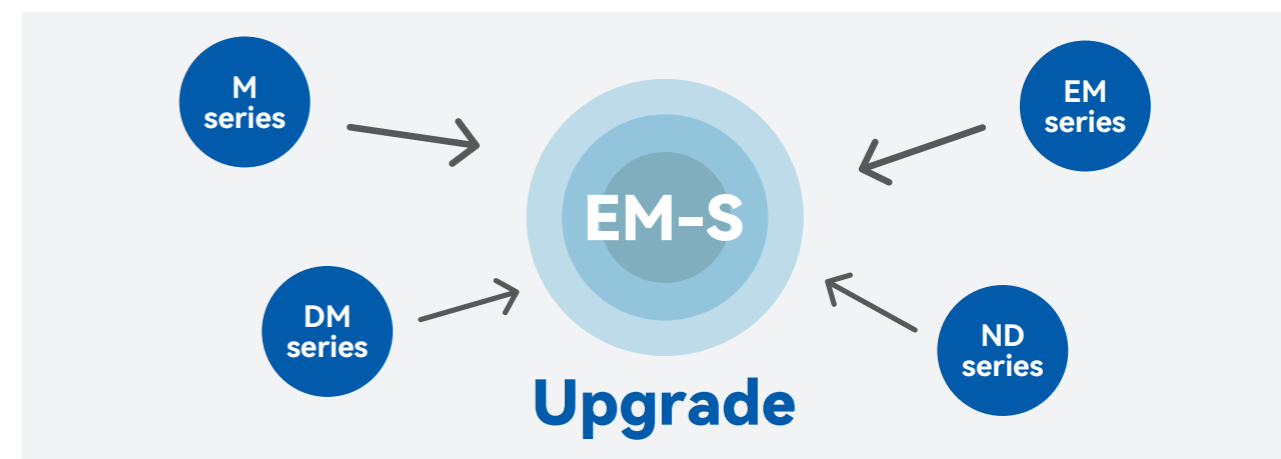

○ Torque comparison (same condition)

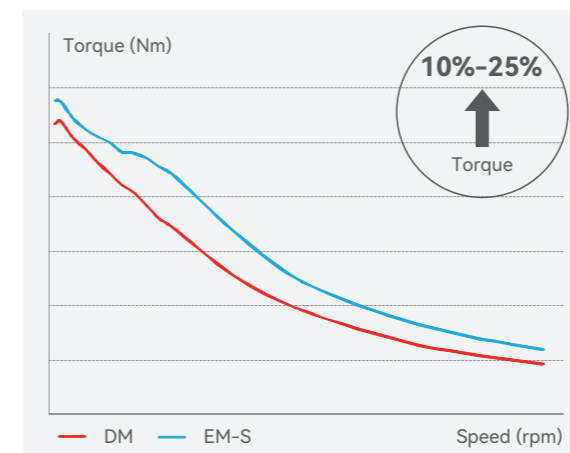

○ Features of Second DIP Switch

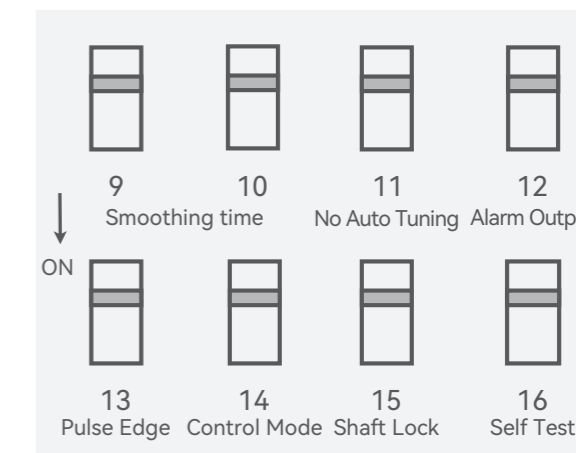

o Pulse Smoothing Filter

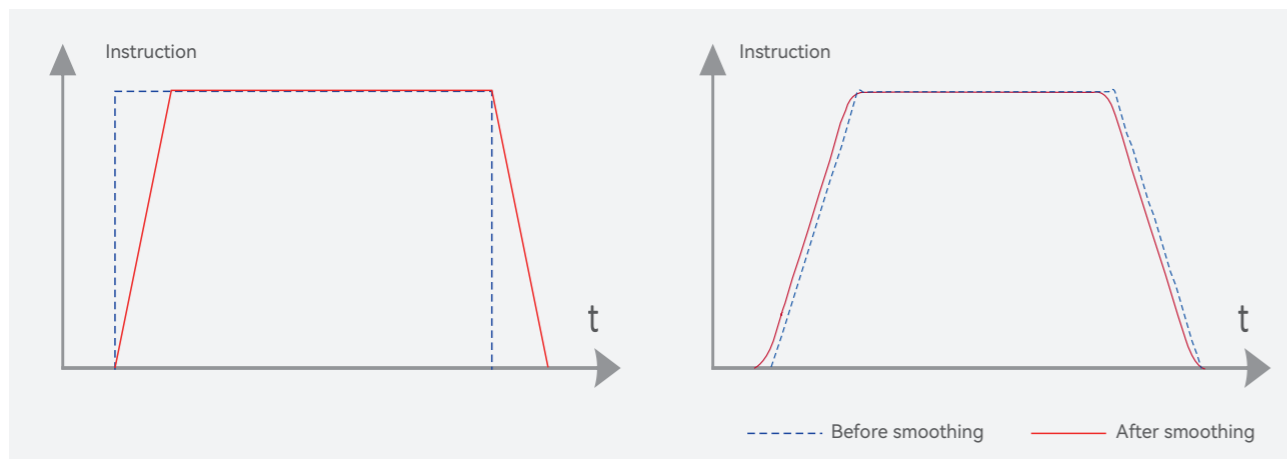

o Alarm and Brake Outputs

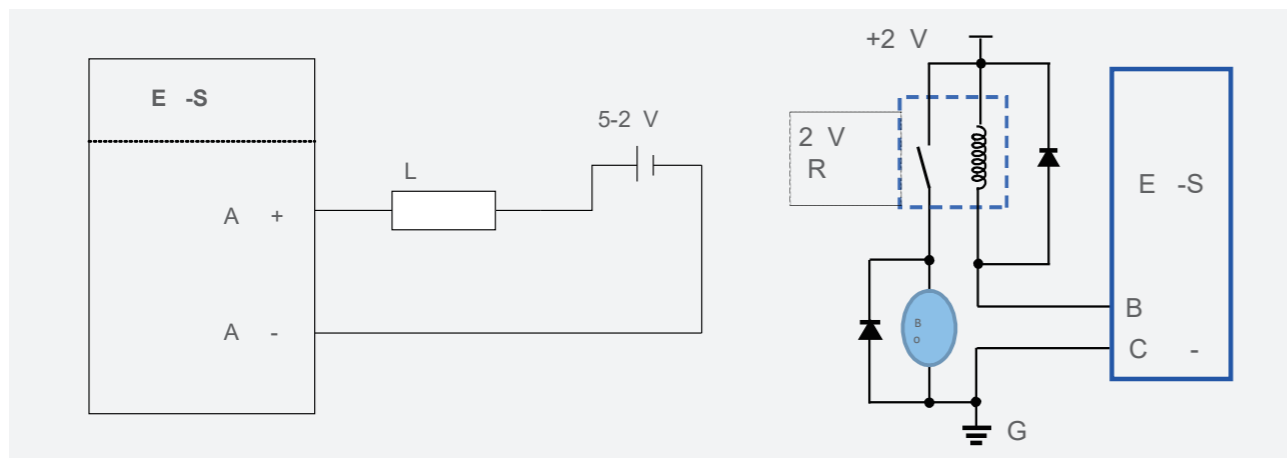

☰ Specifications

Items	EM415S		EM422S		EM532MINI		EM542S		EM556S		EM870S		EM882S	
	Min	Max	Min	Max	Min	Max	Min	Max	Min	Max	Min	Max	Min	Max
Output Current (A)	0.3	1.5	0.3	2.2	0.4	3.2	0.5	4.2	0.5	4.2	0.5	7.0	0.5	8.2
Power Voltage (VDC)	12	40	12	40	18	50	20	50	20	50	20	80	20	80
Max Input Frequency (kHz)	-	70	-	70	-	1000	-	200	-	200 or 500*	-	200	-	200 or 500*
Logical Current (mA)	7	16	7	16	7	16	7	16	7	16	7	16	7	16
Logical Voltage (VDC)	0	5	0	5	0	5	0	5 or 24	0	5 or 24	0	5 or 24	0	5
Min Pulse Width (us)	7.5		7.5		0.5		2.5		2.5 or 1		2.5		2.5 or 1	
Matched Motors Size	NEMA 8/11/14/17		NEMA17		NEMA17/23		NEMA17/23		NEMA23/24		NEMA23/24/34		NEMA34	

Note: (*) The drive with 500kHz is another model.

EM-S Series Interface and Dimensions

(unit: mm, 1 inch=25.4 mm)

EM532 MINI

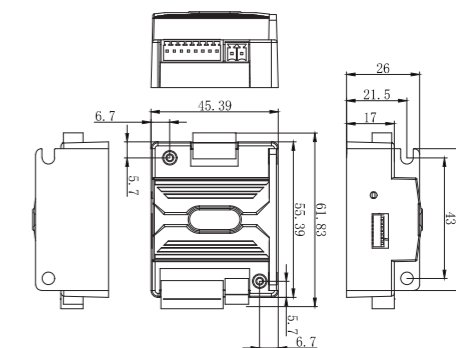
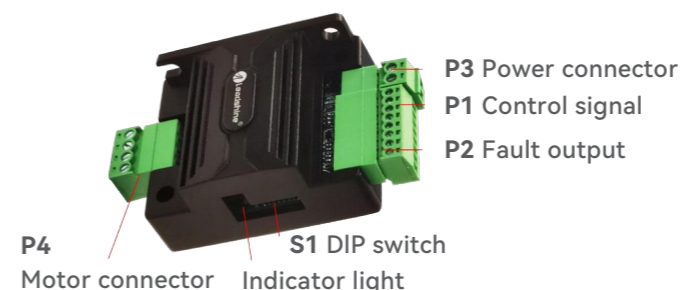

EM415S EM422S

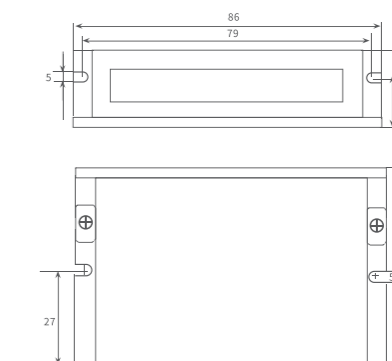
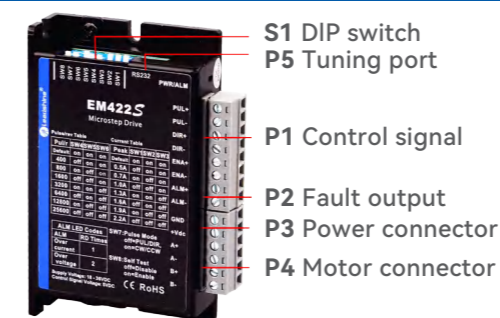

EM542S EM556S EM870S

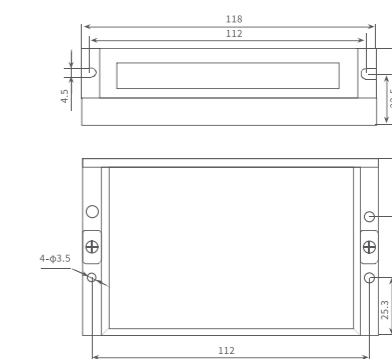
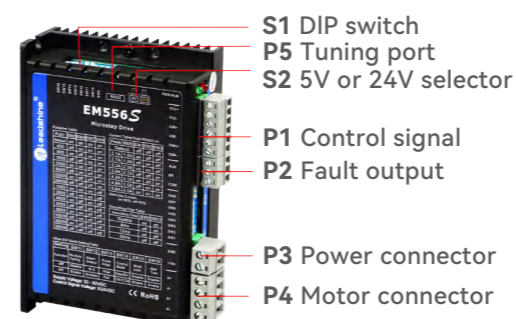

EM882S

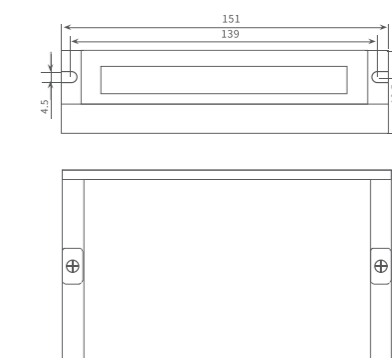
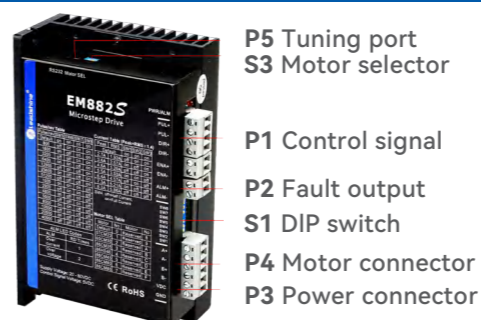

DM-E Series----Cost-effective

The DM-E series consists of stepper drives adopting Leadshine latest advanced stepper control technology. Those stepper drives are highly reliable with good performance and highly competitive cost. They can power a wide range of stepper motors from NEMA 8 to NEMA 34 (model dependent). DM-E stepper drives are easy to configure and setup. Output current and micro step resolution can be simply set up via DIP switches.



DM322E	DM332E	DM542E	DM556E	DMA860E
12-30 VDC	12-30 VDC	20-50 VDC	20-50 VDC	20-80 VAC/ 30-110 VDC
0.3-2.2 A	1.0-3.2 A	1.0-4.2 A	1.7-5.6 A	2.4-7.2 A

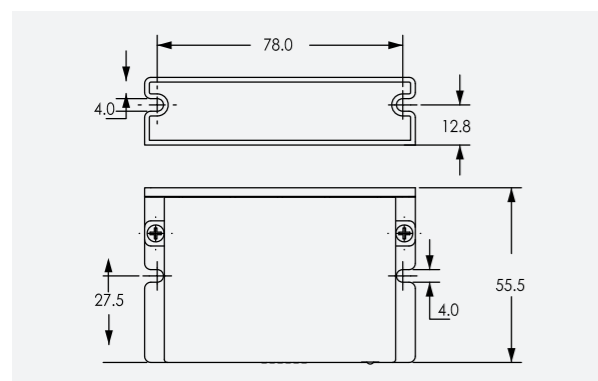

DM322E / DM332E

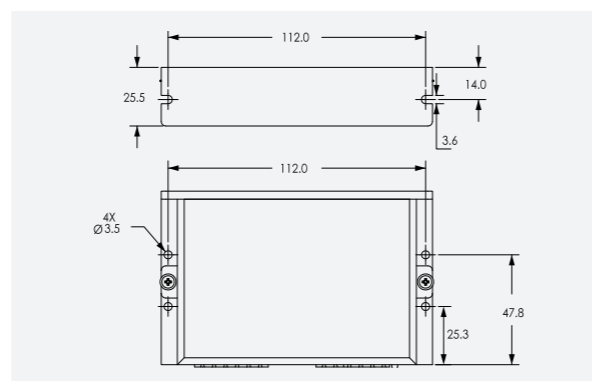

DM542E

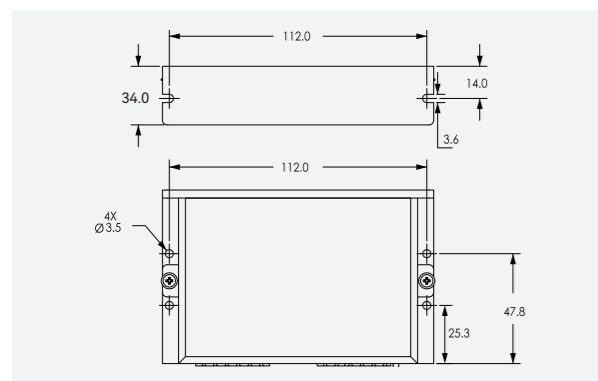

DM556E

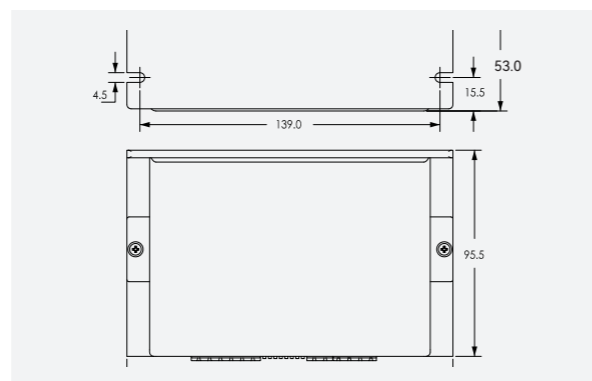

DMA860E

DM Series----AC Power Input

Model	Phase	Power Voltage	Output Current(A)	Control Type	Logical Voltage(VDC)	Phase	Matched Motor Size
DMA860H	2	20-80 VAC or 30-110 VDC	2.4-7.2	Step&Dir, CW&CCW	5	151*97*48	NEMA23/24/34
DMA882S	2	20-80 VAC or 30-110 VDC	0.5-8.2	Step&Dir, CW&CCW	5	151*97*48	NEMA23/24/34
DM1182	2	70-130 VAC	0.5-8.2	Step&Dir, CW&CCW	5	202*167*63	NEMA34/42
DM2282	2	180-240 VAC	0.5-8.2	Step&Dir, CW&CCW	5	202*167*63	NEMA34/42/53

DM Series----AC Power Input

Model	Phase	Power Voltage	Output Current(A)	Control Type	Logical Voltage(VDC)	Phase	Matched Motor Size
3DM580S	3	20-50 VDC	0.5-8.0	Step&Dir, CW&CCW	5	151*97*48	NEMA17/23/24/34
3DM883	3	20-80 VDC	2.2-8.3	Step&Dir, CW&CCW	5	151*97*48	NEMA24/34
3DM2283	3	180-240 VAC	2.2-11.7	Step&Dir, CW&CCW	5	202*167*63	NEMA 34/42/53

Dimensions

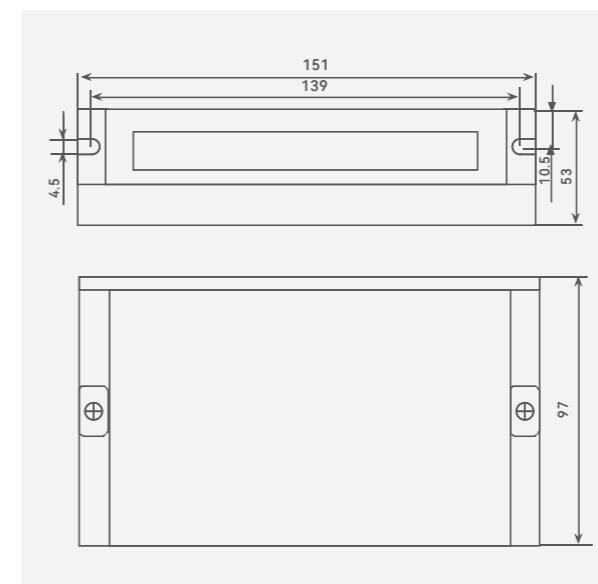

(a) Mechanical specifications of the DMA882S

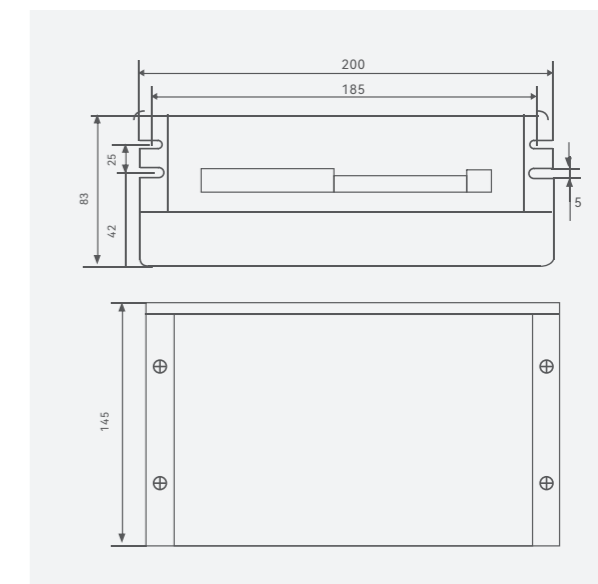

(b) Mechanical specifications of the DM1182

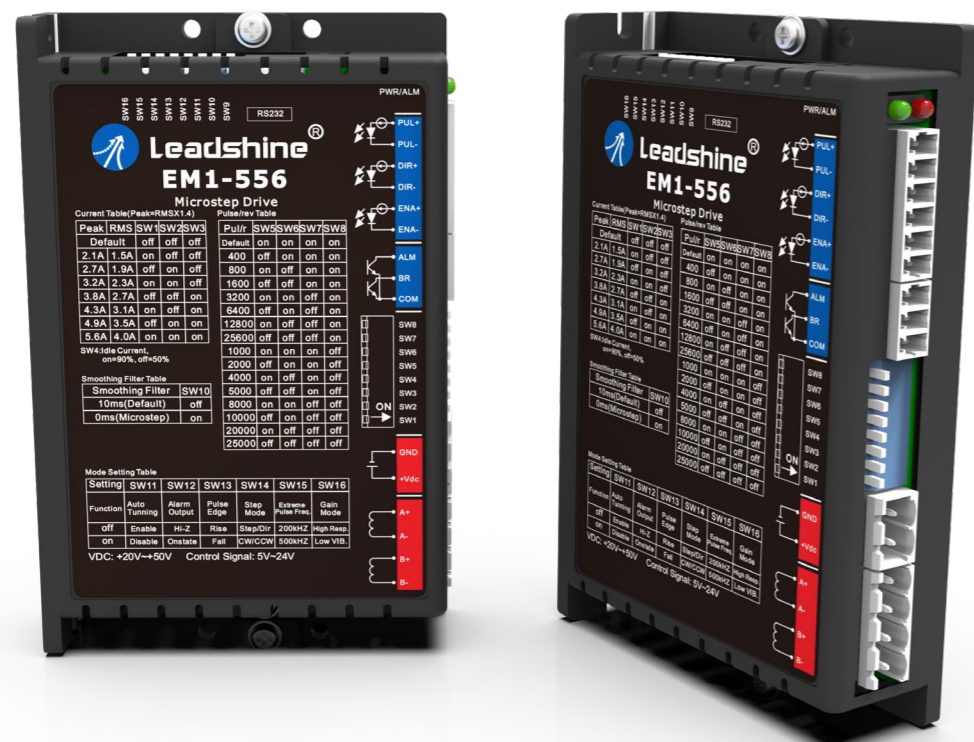

EM1 Series

New Generation Digital Stepper Drive

EM1 series is a new general-purpose pulse stepper driver launched by Leadshine company, which adopts the latest open-loop stepper drive control algorithm and integrates more than 20 years of stepper drive application experience. Outstanding performance

The new EM1 digital series is based on the classic DM series, not only the function has been optimized, the performance has been improved, and the cost has been slightly reduced. The whole series has a debugging port, second sets of functional DIPs and metal heat sinks ensure superior functionality and performance while achieving ultimate stability and reliability.

Overview

NEW Compatible with 5-24 V pulse input

- Opto-coupling isolation supports differential signal input, compatible with 5-24V pulse signal. No resistor required when using 24V input.

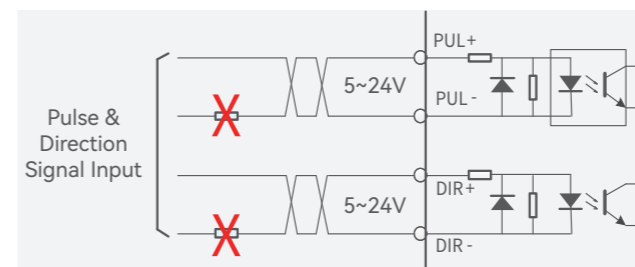

NEW 2nd DIP switches

- Can be used to set filter time, double pulse mode, limit pulse frequency 500 kHz (default 200 kHz), etc.

Dip Switch	Function	Description
SW 9	Microfine / filter setting	-
SW10	-	No filtering / filtering
SW11	auto-tuning setting	Power-on auto-tuning / no auto-tuning
SW12	Alarm output configuration setting	Often open / often closed
SW13	Effective edge settings	Rising edge / falling edge
SW14	Pulse mode setting	Single-pulse / double-pulse
SW15	Limit pulse frequency selection	500kHz / 200kHz

High Response & Low Vibration

- High Response Mode and Low Vibration Mode can be set using 2nd dip switch. Integrated with anti-resonance algorithm, motor jitter can be prevented when running at low speed.

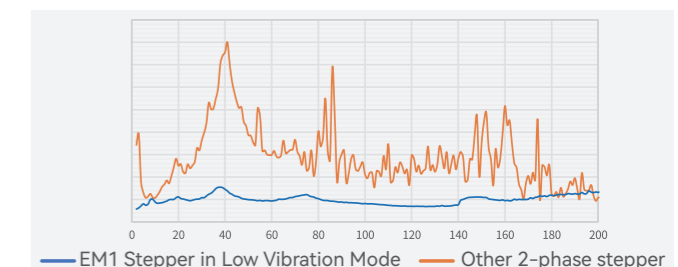

With alarm and brake output

- With alarm and brake output function, suitable for a variety of applications.

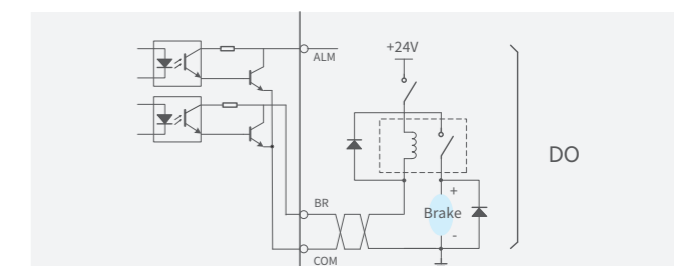

NEW Support both pulse and IO control

- Can be switched using tuning software to meet the operation requirements of more scenarios.

Pulse

Position Mode

IO

Velocity Mode

S-Curve

- Integrated S-Curve acceleration and deceleration. Smooth speed curve, motor starts and stops at more stable pace.



Built-in microscale

- Built-in microcopy power ridge for smooth motion curves.

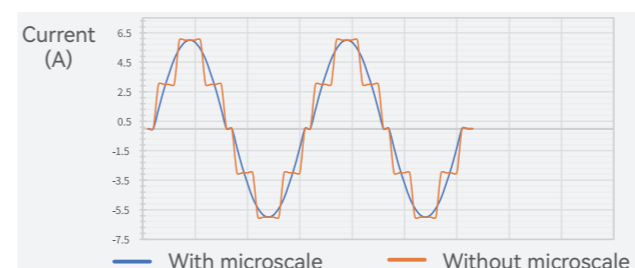

Lower motor running temperature

- High-precision current control, suppress electromagnetic noise, lowering motor temperature.

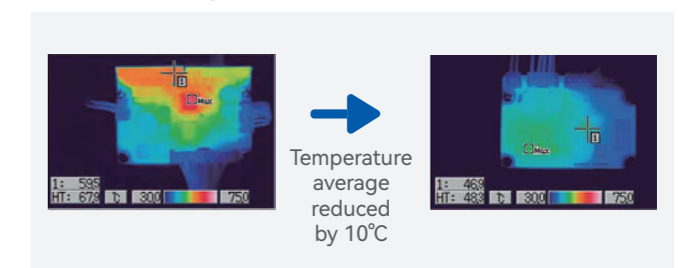

Drive Model						
	EM1-422	EM1-432	EM1-542	EM1-556	EM1-870	EM1-882AC
Dimension (L*W*H)	86*55.5*20.5		118*75.5*25.5	118*75.5*34		151*97*52
Matching Motors (Frame Size)	20/28/35/42	35/42	57	57/60	60/86	86
Input Voltage	20~36Vdc	20~36Vdc	24~50Vdc	24~50Vdc	24~80Vdc	20~70Vac 30~100Vdc
Max. Continuous Current Output	2.2A	3.2A	4.2A	5.6A	7.0A	8.2A
Pulse Voltage Input	5~24Vdc					
Max. Pulse Frequency	200kHz、500kHz Configurable					
Max. Current Output (Signal)	100mA (30Vdc Max. Voltage)					

Dimensions

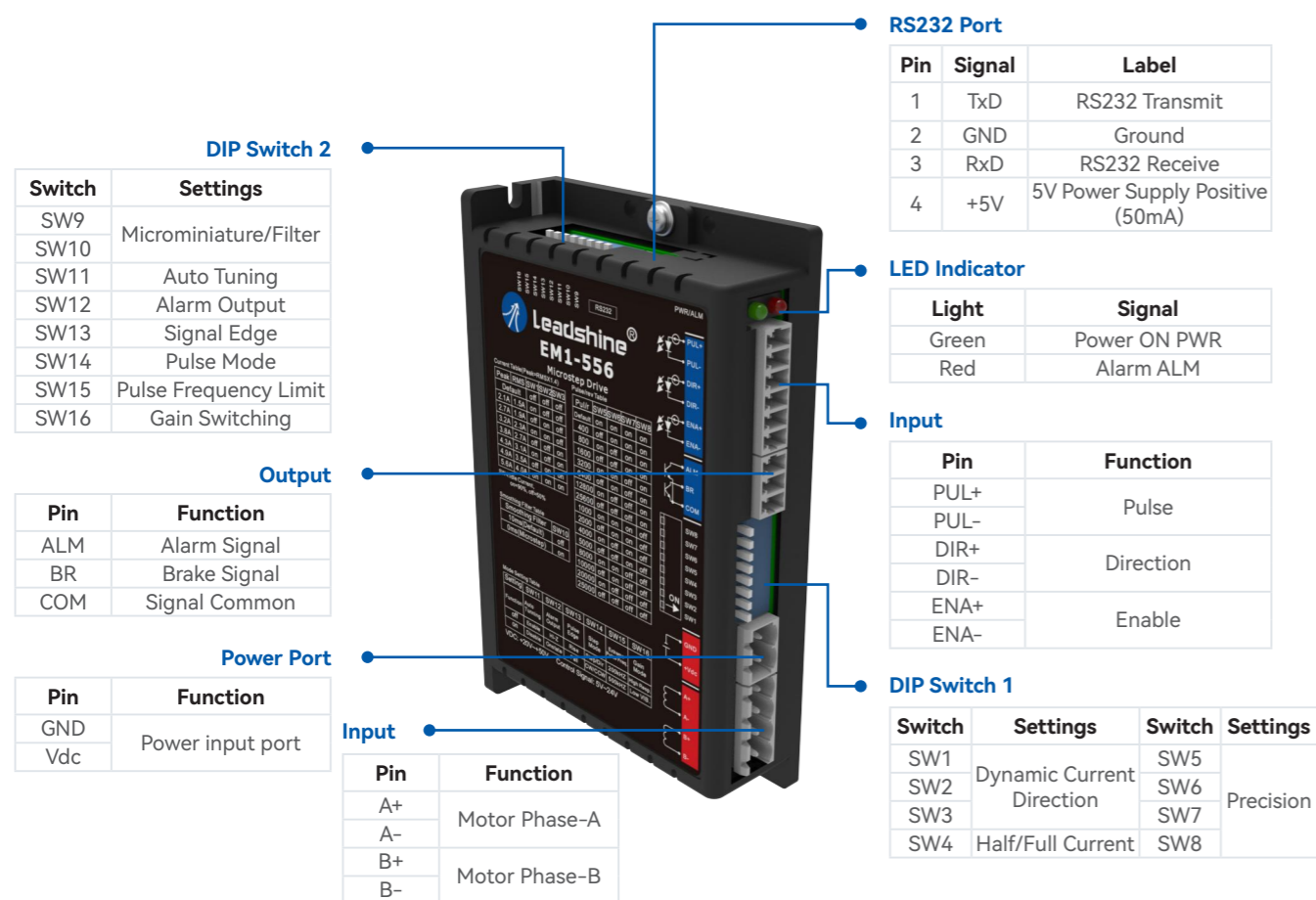
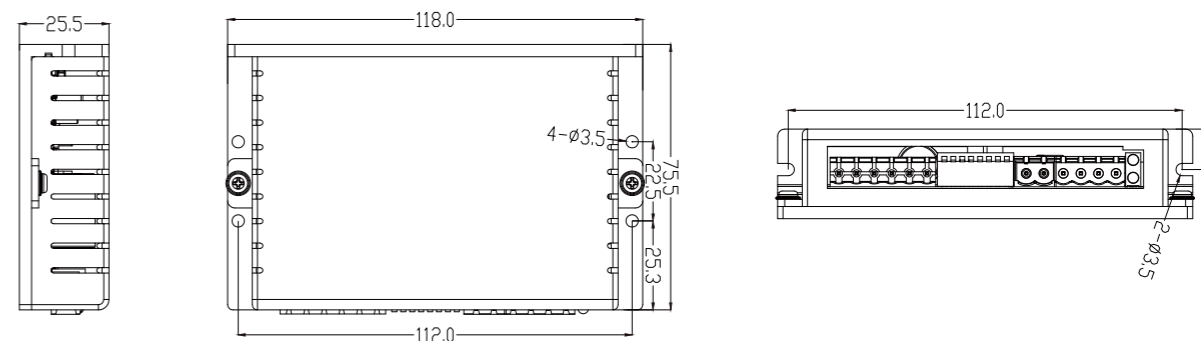

Drive Wiring Diagram

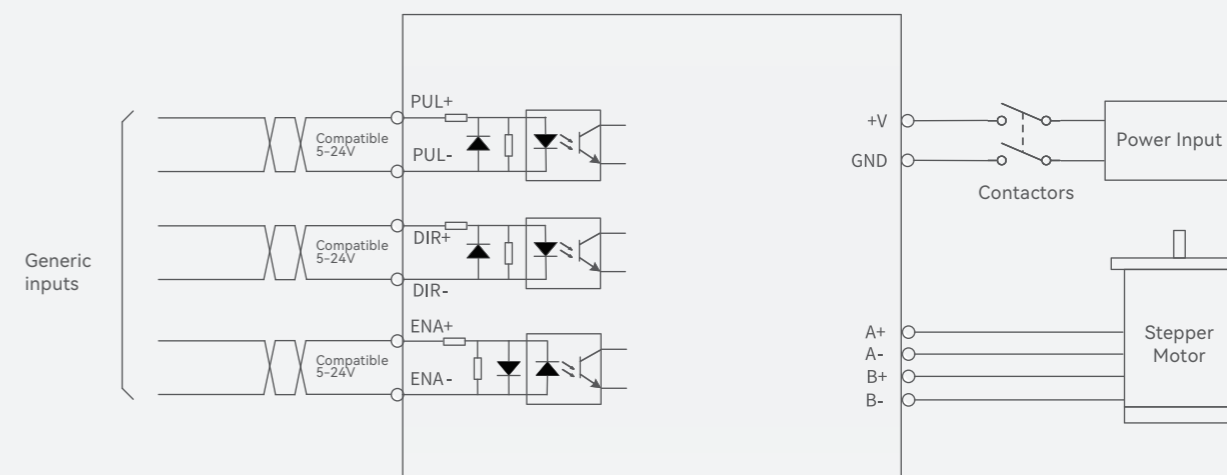

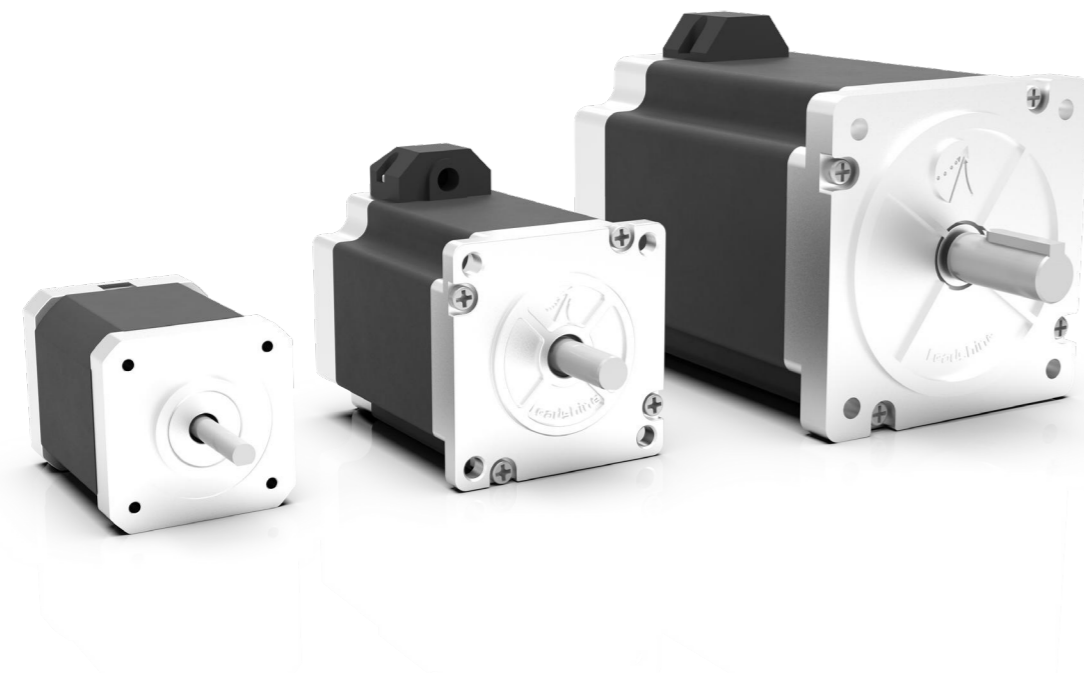

Stepper Motors

CM Series

- Replace HS series stepper motors
- Frame size of NEMA8 to 42
- High reliability, Low motor heating, noise and vibration
- Multiple phase current optional for the same motor

Introduction

By implementing latest design and advanced manufacturing technologies, Leadshine offers hybrid stepper motors in wide frame sizes 8, 11, 14, 16, 17, 23, 24, 34, and 42. Those stepper motors are made of premium quality materials. Compared with ordinary stepper motors on the market. Those stepper motors outperforms in many aspects such as higher torque in all speed ranges, higher precision, lower heating, and lower vibration. Due to the implementation of highly automated manufacturing process and rigid quality assurance control, Leadshine CM series stepper motors are highly reliable with high product consistency.

High Torque:
Latest design for compact size but high torque.

Low Heating:
Use of high quality silicon steel to ensure low motor heating.

Smooth Motion:
Core components from global leading suppliers.

High Consistency:
Highly automated manufacturing process and rigid quality control.

Leadshine CM series stepper motors are available in the following options:

- Standard single shaft stepper motors.
- Stepper motors with planetary gearboxes.
- IP 65 waterproof stepper motors.
- Stepper motors with encoder, brake, gearboxes.
- Dual shaft stepper motors.
- Stepper motors with encoders (also called closed loop stepper motors).
- Stepper motors with electromagnetic brakes.

Leadshine CM stepper motors have been widely implemented in many industrial applications such as CNC routers, laser cutters, plasmas, plotters, medical equipment, Battery manufacturing product lines, textile machines, packaging machines, etc.



Stepper Motor with brake

=



CM Series Stepper Motor

+



Low noise
Quick response
Low heat

Permanent magnet brake

CM series waterproof stepper motor, compared with the standard type, the back cover is redesigned, the lead wire is changed to waterproof connector, new sealing material is added between the front & back cover and the body, the motor body is made a comprehensive waterproof treatment, the motor shaft is selected high quality oil seal, so that the motor IP rate is IP65. can be applied to all kinds of wet, water, outdoor, oil splashing occasions.



DM Series -- AC Power Input

Step Angle	1.8°
Position Accuracy	±0.09°
Temp Rise(Max.)	Max. 85K
Operation Environment	Temperature: -10°C - +50°C; Humidity: Max. 85%
Insulation Class	B
Insulation Resistance	Min. 100 MΩ, 500 V DC
Dielectric Strength	500 VAC, 1 min
Radial Play	0.025 mm Max. (Load 5N)
Axial Play	0.075 mm Max. (Load 10N)

Installation & Operation Conditions

Motor Size	NEMA17	NEMA23	NEMA24	NEMA34
Store Temperature	-10°C ~ +50°C			
Store Humidity	Max. 85%			
Operation Environment	Non-corrosive gas and dust; No direct contact with water, oil (except the waterproof type)			
Radial Load(N) (Distance to the flange 10mm)	30	75	90	300
Axial Load(N)	Less than motor weight			

NEMA 8 (20mm)

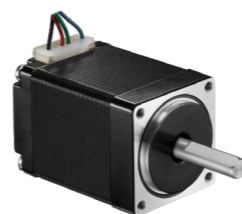

Models	Length (mm)	Holding Torque (N.m)	Rate Current (A)	Resistance/Phase (Ω)	Inductance/Phase (mH)	Inertia (kgm ² *10 ⁻⁴)	Matched Drives
20CM003	33	0.03	0.6	5.7	2.6	0.003	EM415S
20CM005	45	0.05	0.6	7	3.4	0.004	EM415S

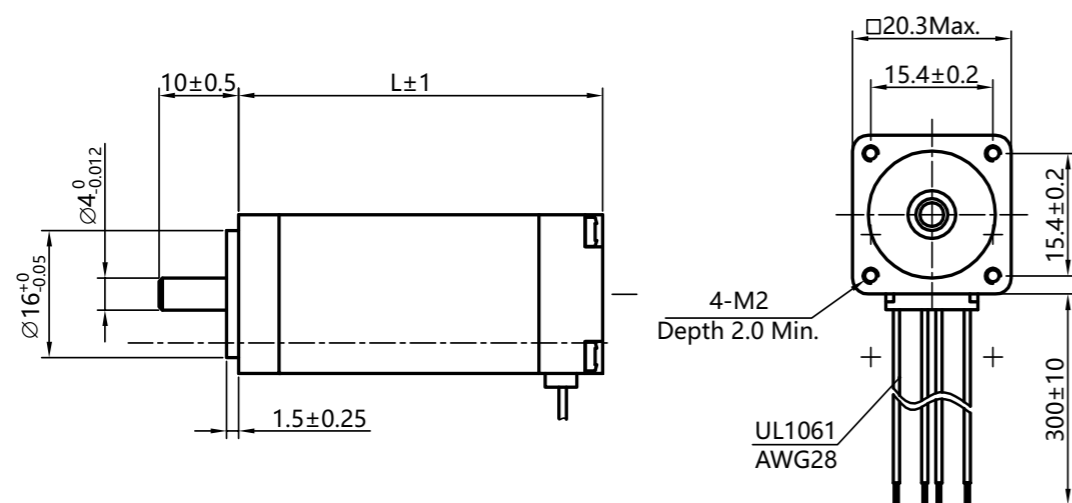

NEMA 11 (28mm)

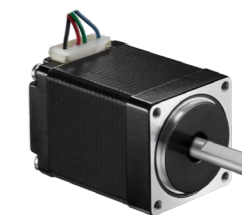

Models	Length (mm)	Holding Torque (N.m)	Rate Current (A)	Resistance/Phase (Ω)	Inductance/Phase (mH)	Inertia (kgm ² *10 ⁻⁴)	Matched Drives
28CM006	32	0.06	1.2	1.4	1.0	0.009	EM415S
28CM010	41	0.1	1.2	1.8	1.6	0.013	EM415S
28CM013	51	0.13	1.2	2.2	2.3	0.018	EM415S

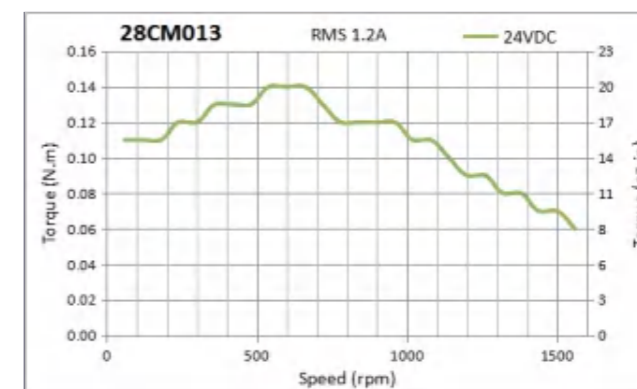
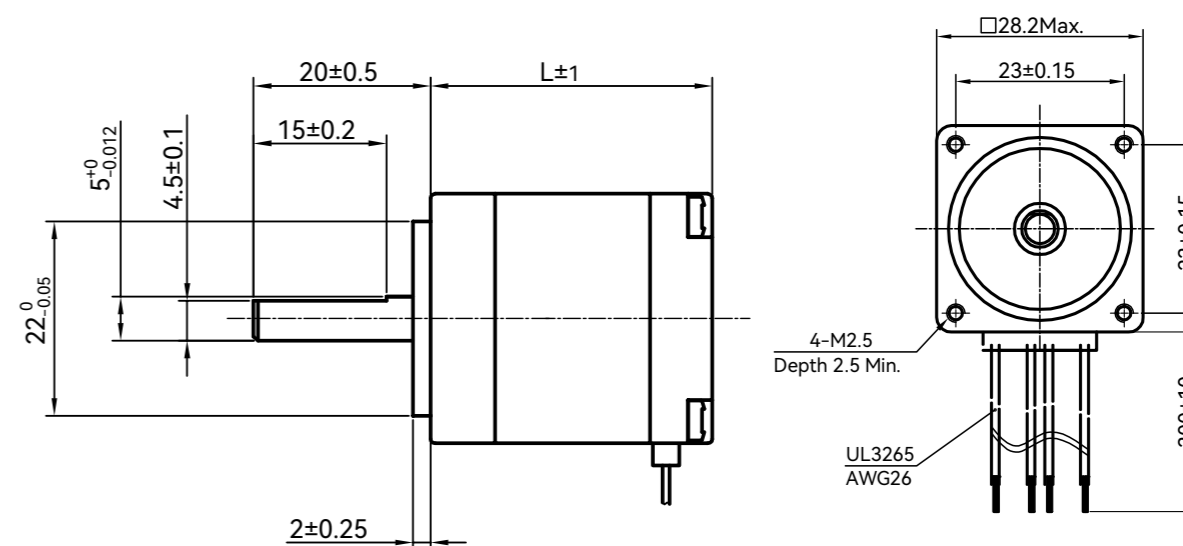

NEMA 14 (35mm)

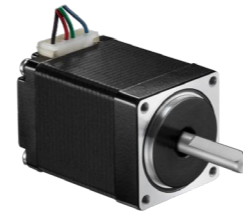

Models	Length (mm)	Holding Torque (N.m)	Rate Current (A)	Resistance/Phase (Ω)	Inductance/Phase (mH)	Inertia (kgm ² *10 ⁻⁴)	Matched Drives
35CM015	31	0.15	2	0.8	1.3	0.019	EM422S
35CM04	47	0.36	2	1.2	1.9	0.026	EM422S

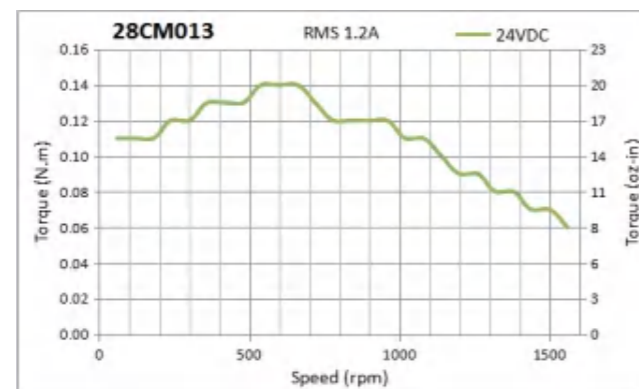
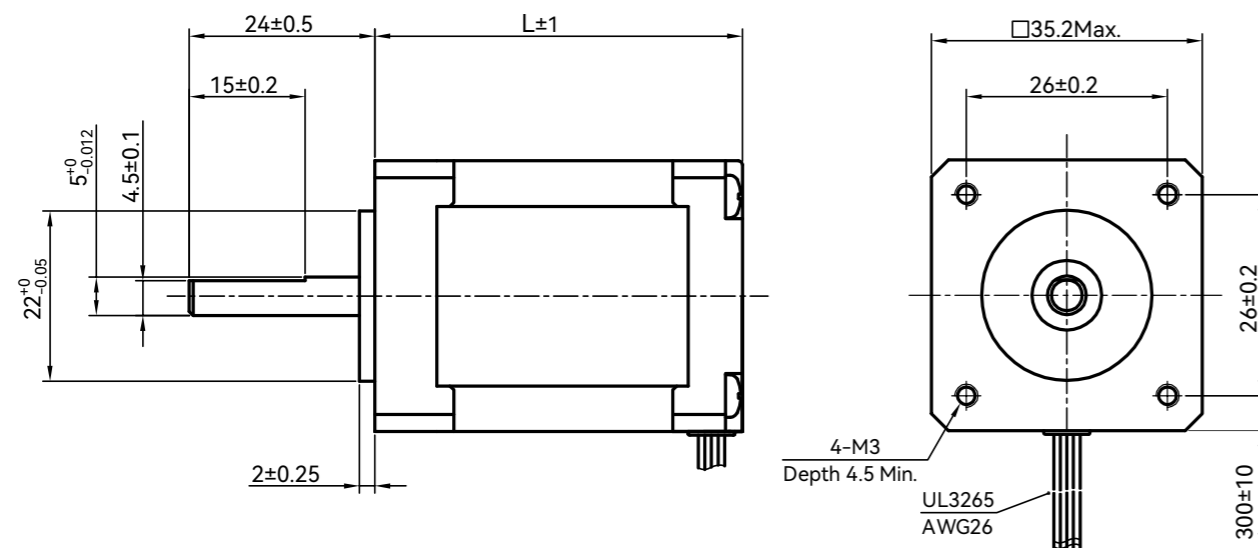

NEMA 17 (42mm)



Models	Length (mm)	Holding Torque (N.m)	Rate Current (A)	Resistance/Phase (Ω)	Inductance/Phase (mH)	Inertia (kgm ² *10 ⁻⁴)	Matched Drives
42CM02-1A	33	0.21	1	4.5	6.5	0.035	EM415S
42CM02		0.21	1.5	1.4	1.4	0.035	EM422S
42CM04-1A	40	0.4	1	4.0	7.9	0.054	EM415S
42CM04		0.4	1.5	2.3	4.3	0.054	EM422S
42CM06-1A	47	0.6	1.5	2.2	4.5	0.072	EM422S
42CM06		0.6	2.5	0.9	1.6	0.072	EM532MINI
42CM08-1A	60	0.8	1.5	3.0	6.9	0.110	EM422S
42CM08		0.8	2.5	1.0	2.4	0.110	EM532MINI

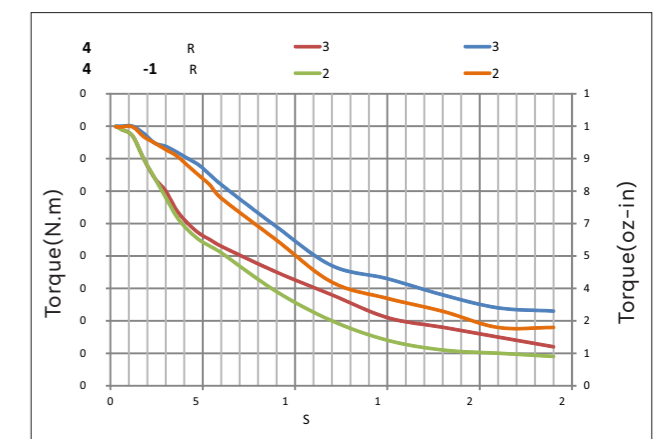
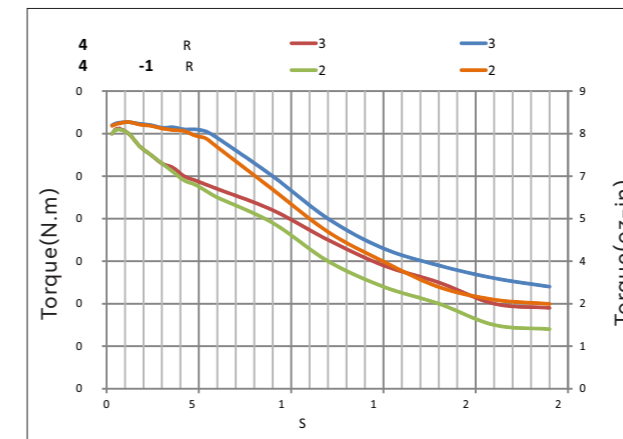
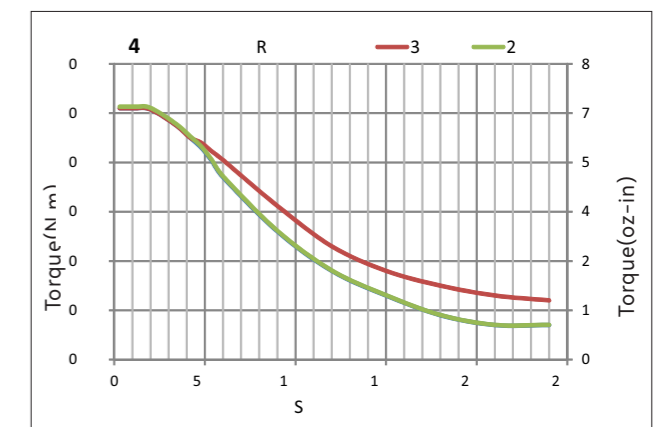
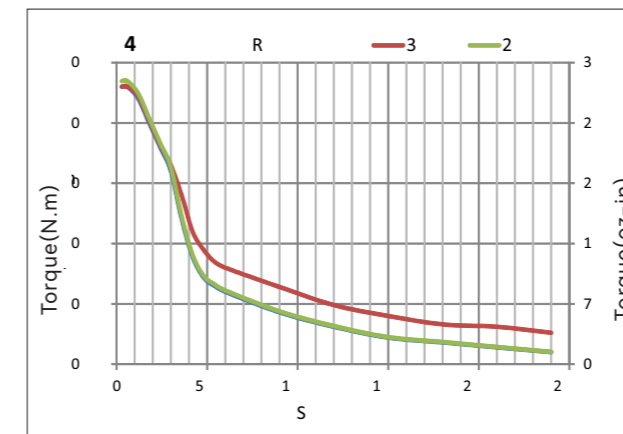
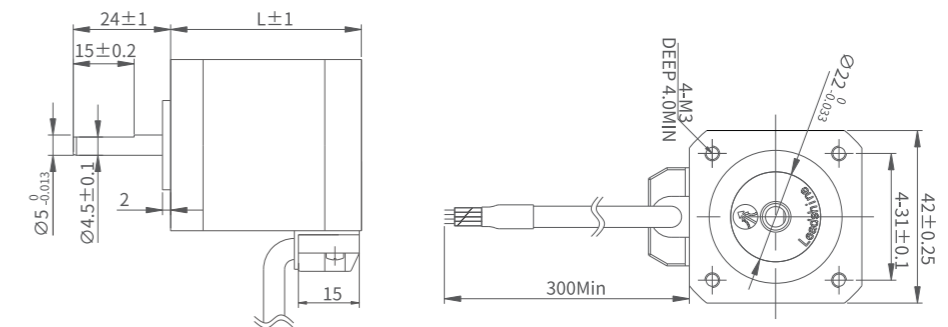

NEMA 23 (57mm)



Models	Length (mm)	Holding Torque (N.m)	Rate Current (A)	Resistance/Phase (Ω)	Inductance/Phase (mH)	Detent Torque	Inertia (kgm ² *10 ⁻⁴)	D (mm)	Matched Drives
57CM06	41	0.6	3	0.7	1.4	0.02	0.12	6.35	EM542S
57CM13-3A	55	1.3	3	0.8	2.8	0.04	0.3	6.35	EM542S
57CM13		1.3	4	0.42	1.6			6.35	EM542S/EM556S
57CM12X		1.2	4	0.6	1.4			6.35	EM542S/EM556S
57CM21X	76	2.1	4	0.6	2.4	0.07	0.48	8	EM542S/EM556S
57CM23-3A		2.1	3	1.1	4.2			8	EM542S
57CM23-4A	76	2.3	4	0.5	2			8	EM542S/EM556S
57CM23		2.3	5	0.38	1.75			8	EM556S
57CM22X	80	2.2	5	0.34	1.74	0.07	0.5	8	EM556S/EM870S
57CM26-4A	85	2.6	4	0.8	3.2	0.08	0.52	8	EM542S/EM556S
57CM26		2.6	5	0.44	2			8	EM556S/EM870S

Note: Motors with 1/4 in(6.35mm) shaft diameter are available.

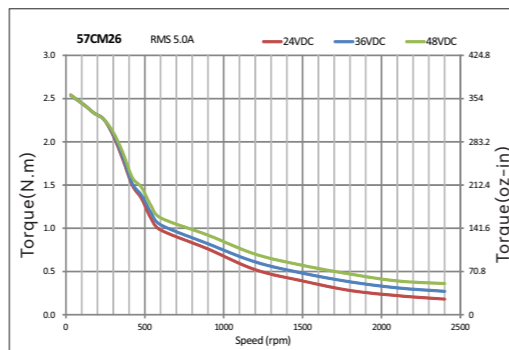
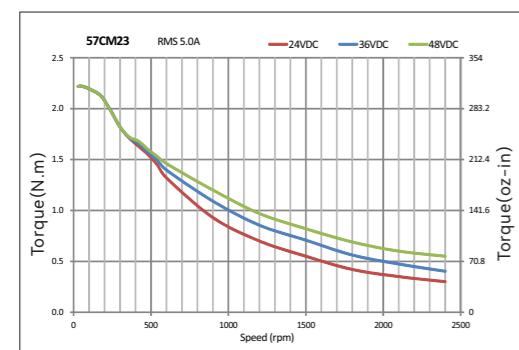
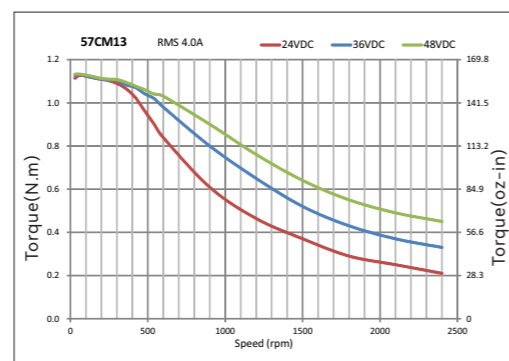
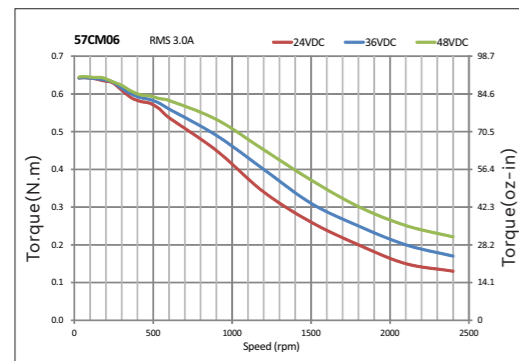
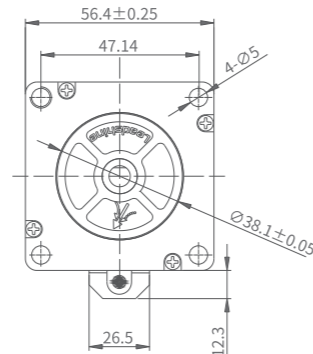
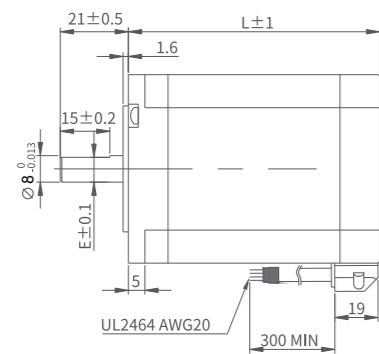

NEMA 23 (57mm)

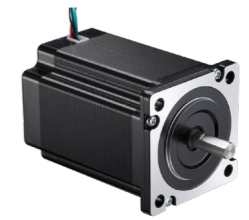
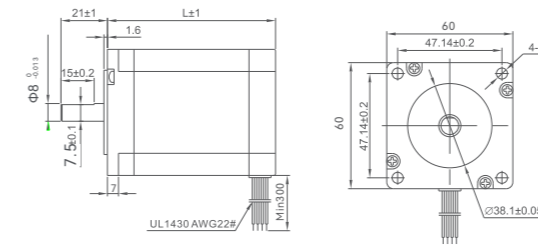

Models	Length (mm)	Holding Torque (N.m)	Rate Current (A)	Resistance/Phase (Ω)	Inductance/Phase (mH)	Detent Torque (N.m)	Inertia (kgm ² *10 ⁻⁴)	D (mm)	Matched Drives
D57CM21-4A	67	2.1	4	0.5	1.77	0.09	0.57	7.5	EM556S
D57CM21		2.1	5	0.21	0.75			7.5	EM556S/EM870S
D57CM31-4A	88	3.1	4	0.62	2.8	0.10	0.84	7.5	EM556S
D57CM31		3.1	5	0.26	1.18			7.5	EM556S/EM870S

NEMA 24 (60mm)

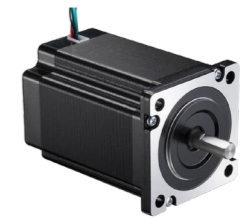

Models	Length (mm)	Holding Torque (N.m)	Rate Current (A)	Resistance/Phase (Ω)	Inductance/Phase (mH)	Detent Torque (N.m)	Inertia (kgm ² *10 ⁻⁴)	D (mm)	Matched Drives
60CM22X	67	2.2	5	0.33	1.05	0.07	0.49	8	EM556S/EM870S
60CM30X	85	3.0	5	0.46	2.0	0.08	0.69	8	EM556S/EM870S

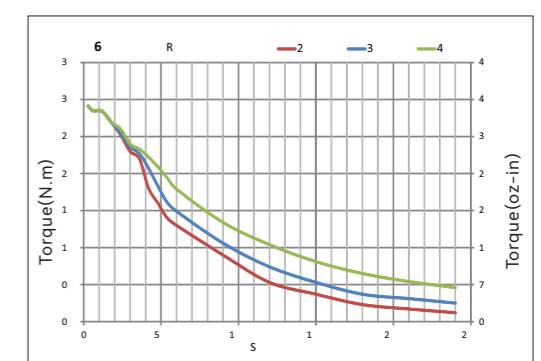
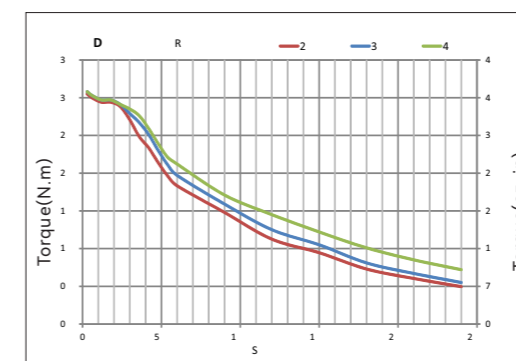
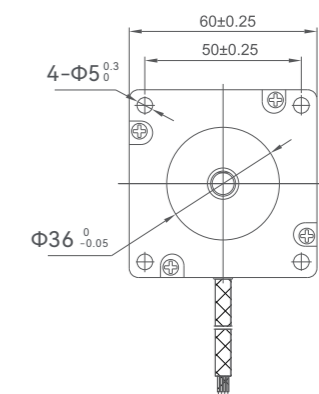
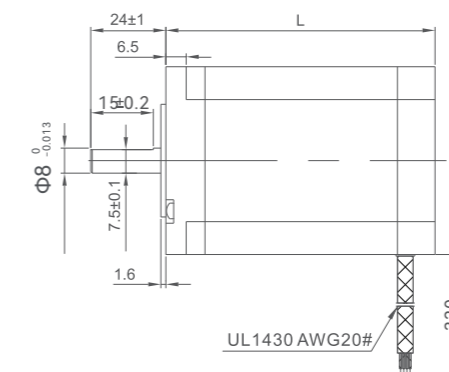

NEMA 34 (86mm)



Models	Length (mm)	Holding Torque (N.m)	Rate Current (A)	Resistance/Phase (Ω)	Inductance/Phase (mH)	Inertia (kgm ² *10 ⁻⁴)	D (mm)	Matched Drives
86CM35	65	3.5	4	0.42	1.00	1.00	12.7	EM556S/EM870S
86CM45	80	4.5	6	0.43	2.95	1.40	12.7	EM882S
86CM80	98	8.0	6	0.63	4.0	2.50	12.7	EM882S
86CM85	118	8.5	6	0.53	4.25	2.70	12.7	EM882S
86CM120	129	12.0	6	0.75	5.30	2.94	14	EM882S/DMA882S

Note: Motors with 1/4 in(6.35mm) shaft diameter are available.

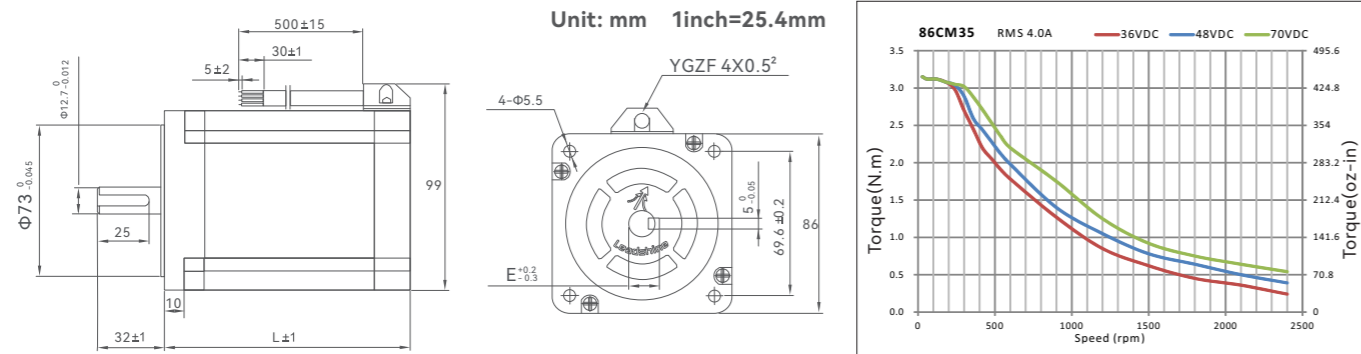

NEMA 42 & 51 (110mm & 130mm)



Models	Length (mm)	Holding Torque (N.m)	Rate Current (A)	Resistance/Phase (Ω)	Inductance/Phase (mH)	Inertia (kgm ² *10 ⁻⁴)	D (mm)	Matched Drives
110CM12	115	12	6	0.53	6.5	7.2	19	DM2282
110CM20	150	20	6	0.8	15	10.9	19	DM2282
110CM28	201	28	6.5	1.2	22	16.2	19	DM2282
130HS27	227	27	6	0.86	12.5	15.7	19	DM2282
130HS45	283	45	7	0.66	9.0	22.9	19	DM2282

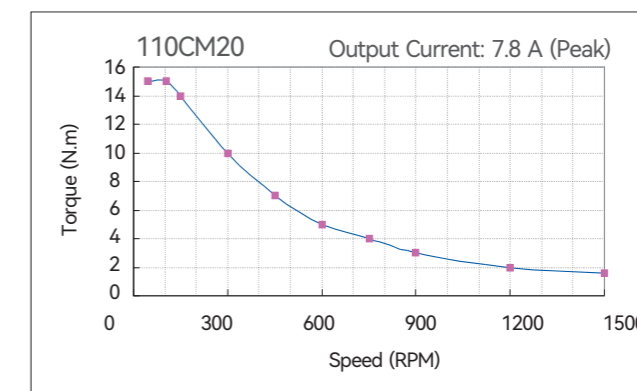
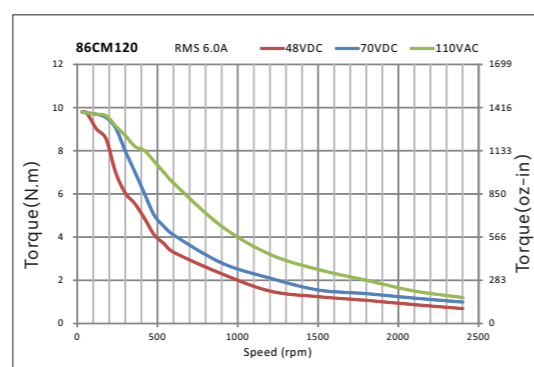
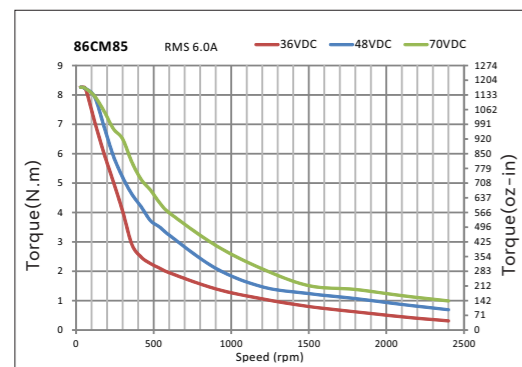
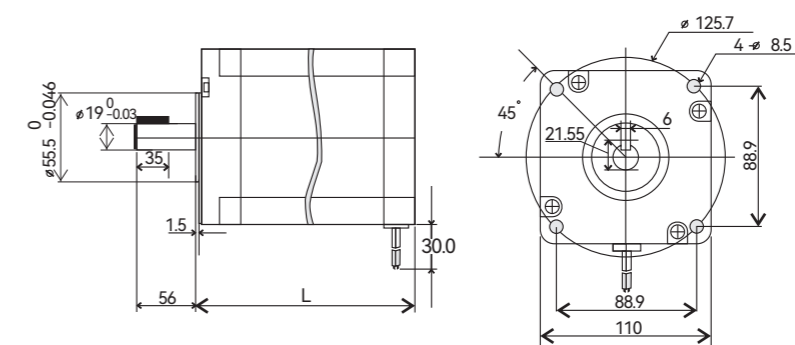
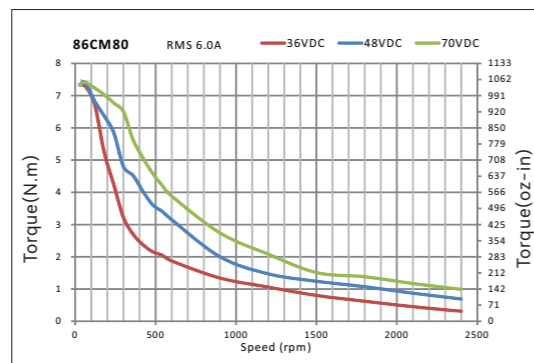
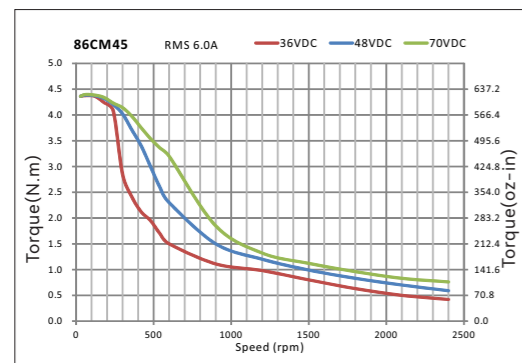
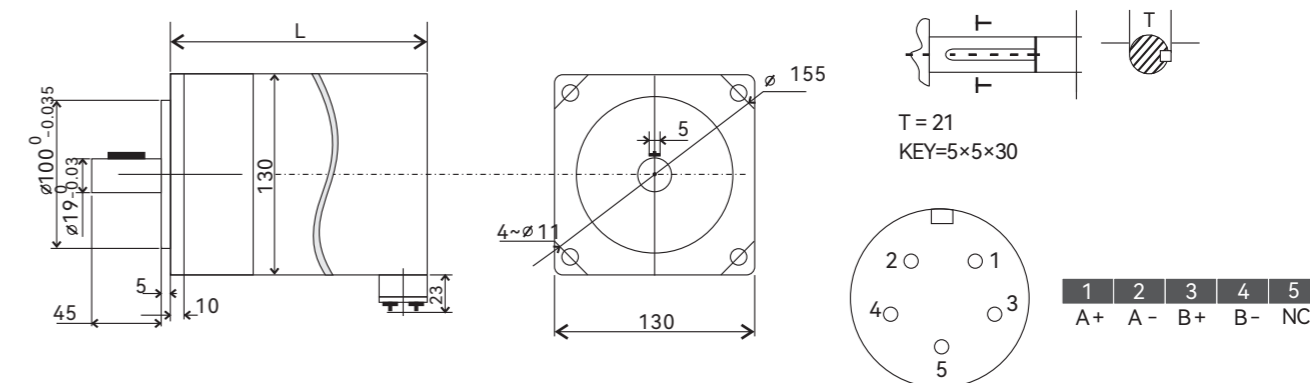

3-phase:NEMA 23, 34, 42

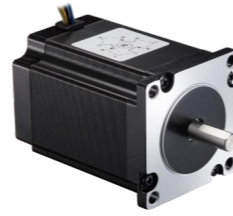

Models	Length (mm)	Holding Torque (N.m)	Rate Current (A)	Resistance/Phase (Ω)	Inductance/Phase (mH)	Inertia (kgm ² *10 ⁻⁴)	D (mm)	Matched Drives
573S09	50	0.9	3.5	0.77	1.8	1.00	6.35	3DM580S
573S15	76	1.3	5.8	0.86	2.0	1.40	8	3DM580S
863S22	71	2.3	5	0.9	2.8	2.50	12	3ND883
863S42	103	4.3	5	1.35	4.5	2.70	12	3ND883
863S68H	135	6.8	2.3	4.5	20	2.94	14	3DM2283

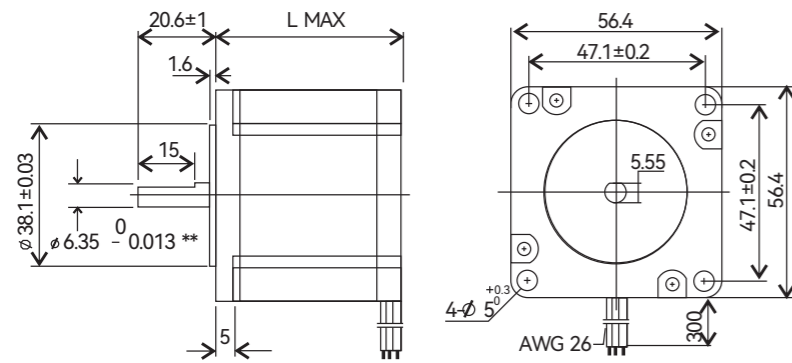
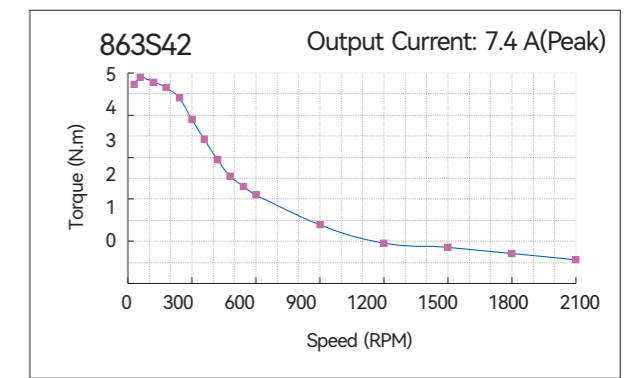
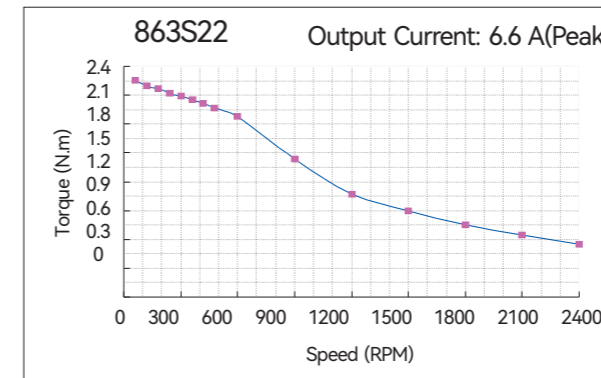
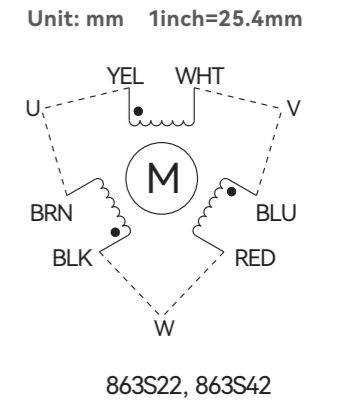
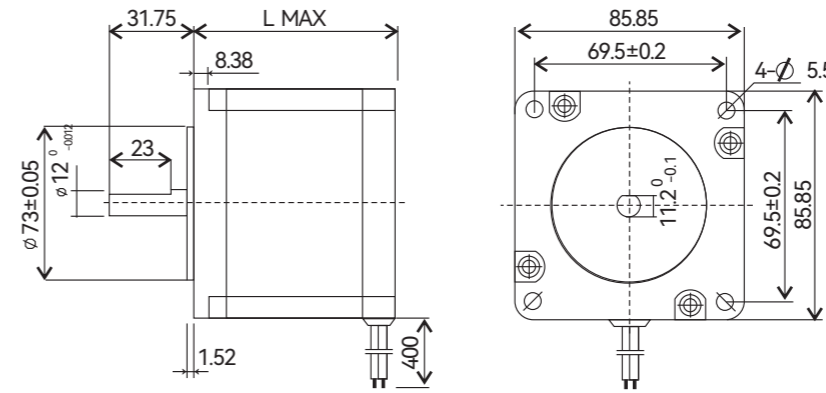

Unit: mm 1inch=25.4mm

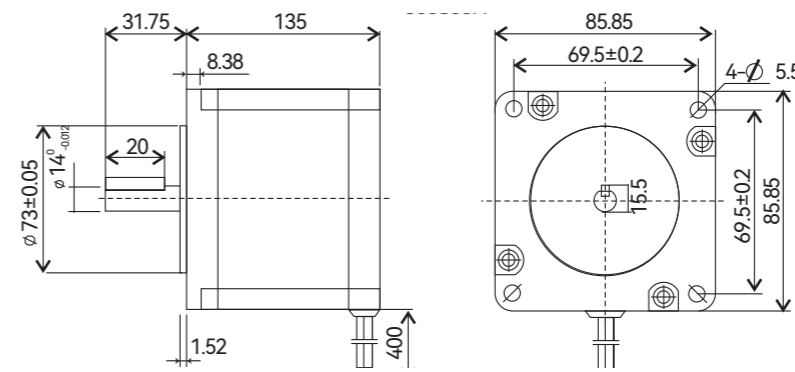
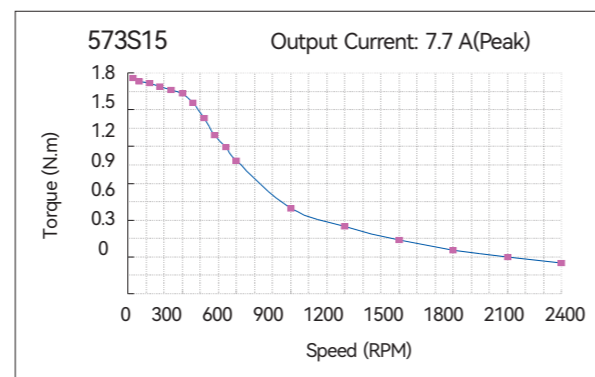
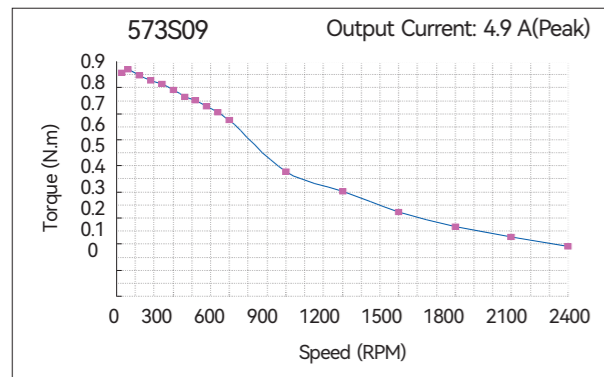
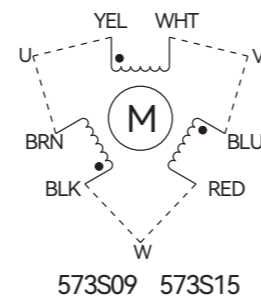

Unit: mm 1inch=25.4mm

Specifications of Motor Shafts			
Model	T	KEY	D
863S68H	15.5	4*4*20	14

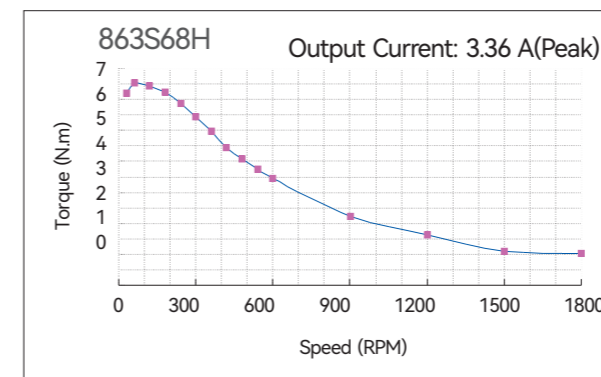
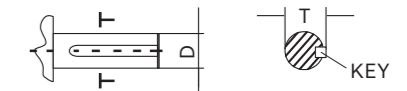



DM5 Series

5-phase Stepper Drive

DM5 series is a new high-end five-phase stepper driver launched by Leadshine, DM5 series includes pulse type and EtherCAT bus type, which has a series of advantages such as higher precision, faster response, lower vibration, smaller size, simple and easier operation, more diverse installation methods, more powerful functions, and more intelligent network.

DM5 series is suitable for import substitution occasions of various high-end equipment, and can be widely used in semiconductor, medical, precision dispensing, wire cutting, laser, engraving and other industry equipment.

Overview

Higher accuracy than two-phase stepper

The basic step angle of the 5-phase stepper motor is 0.72° , and the stopping accuracy can reach 0.05° , which can achieve higher positioning accuracy compared with the 2-phase stepper motor.

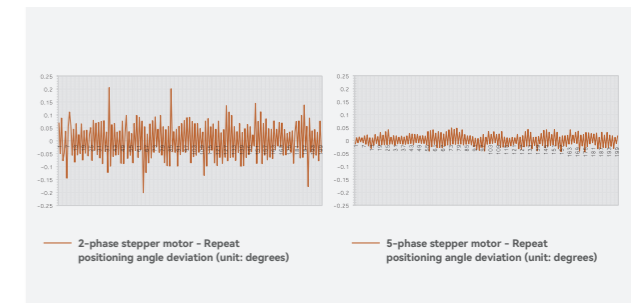

Faster response than AC servo

Compared with AC servo drive, the 5-phase stepper motor has the advantages of more pole pairs, open-loop control, no setting time, faster response speed, and shorter positioning time.

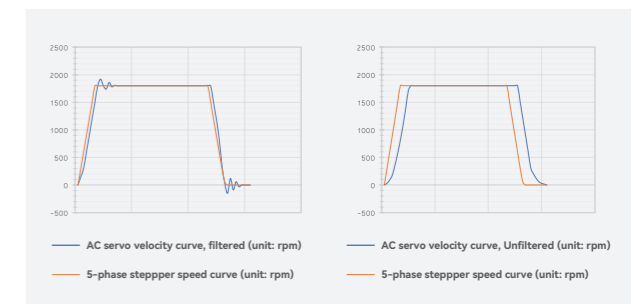

Lower vibration than 2-phase stepping

The basic step angle of the 5-phase stepper motor is 0.72° , which is less fluctuating in speed and less vibration and noise than the 2-phase stepper motor with a basic step angle of 1.8° .

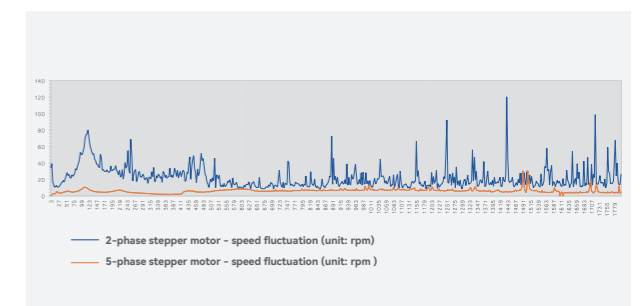

Small size, large energy, Type-C tuning interface, easy to use

small size, huge energy, maximum driving current up to 4A.

Support USB power supply: the driver does not need to be powered on, and the parameters can be modified by plugging in the Type-C data cable;

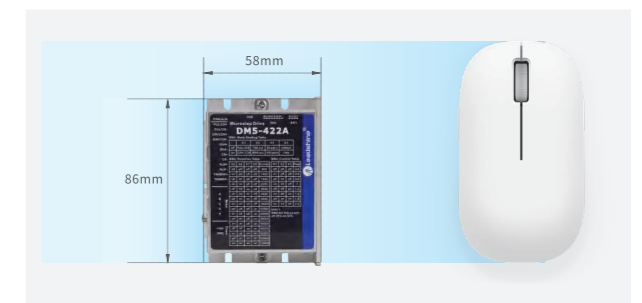

DM5 Series

High-end 5-phase pulse control stepper drives

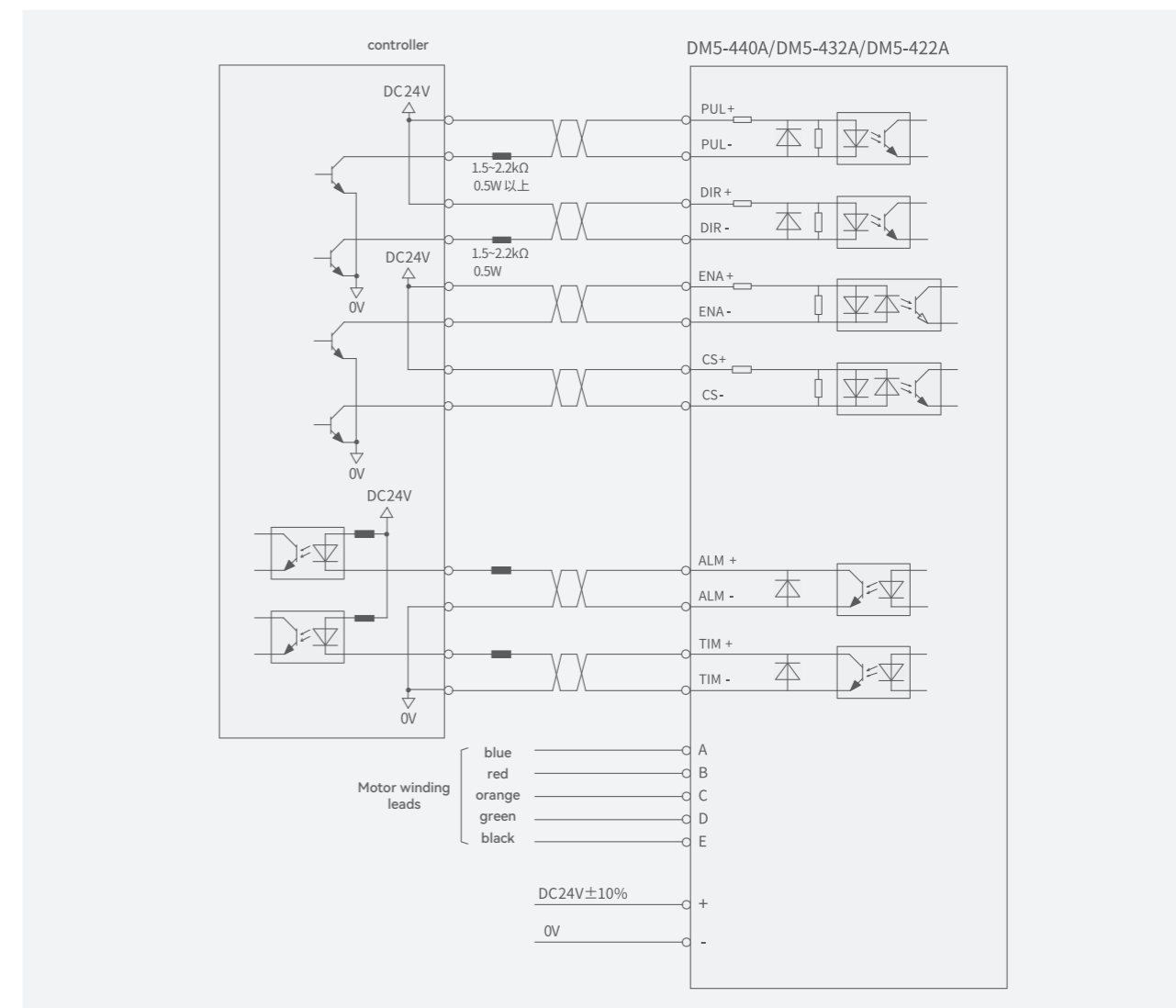
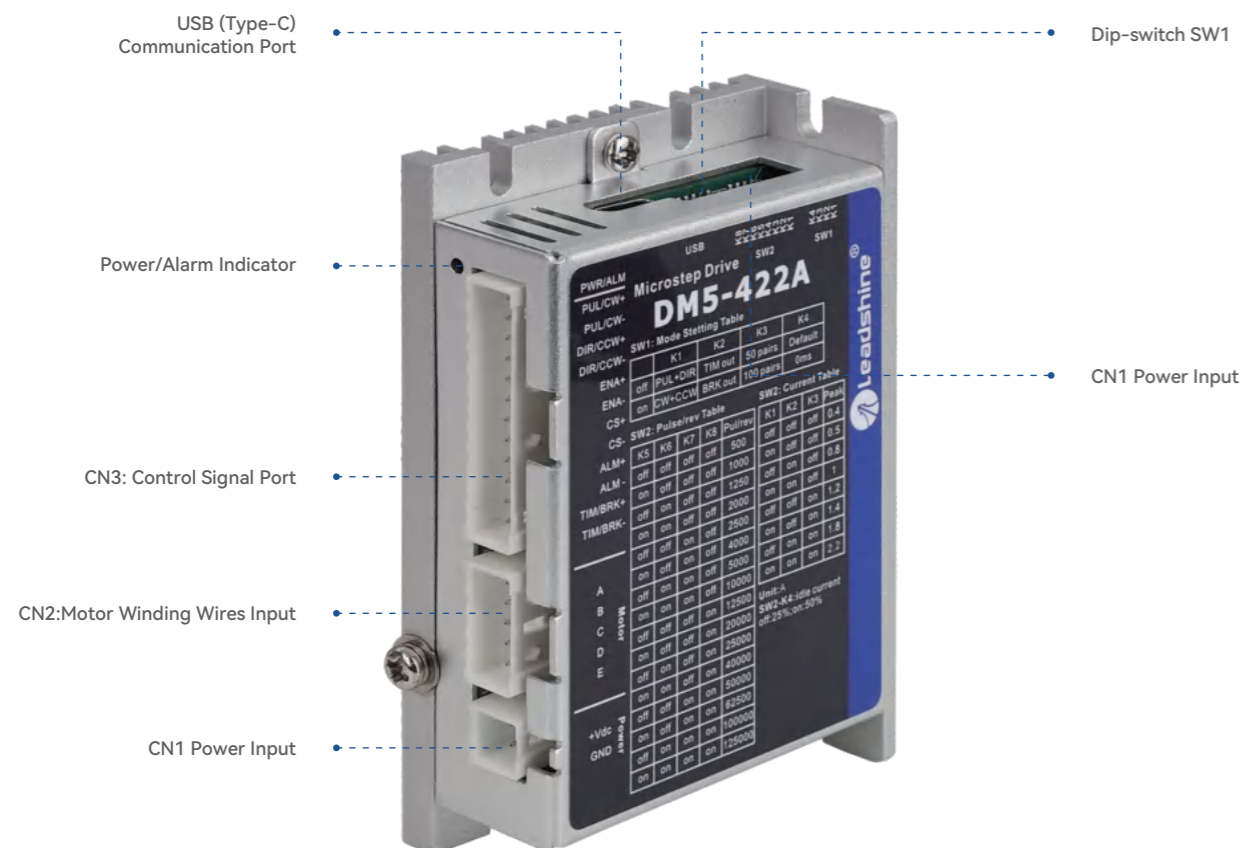

DM5 Series

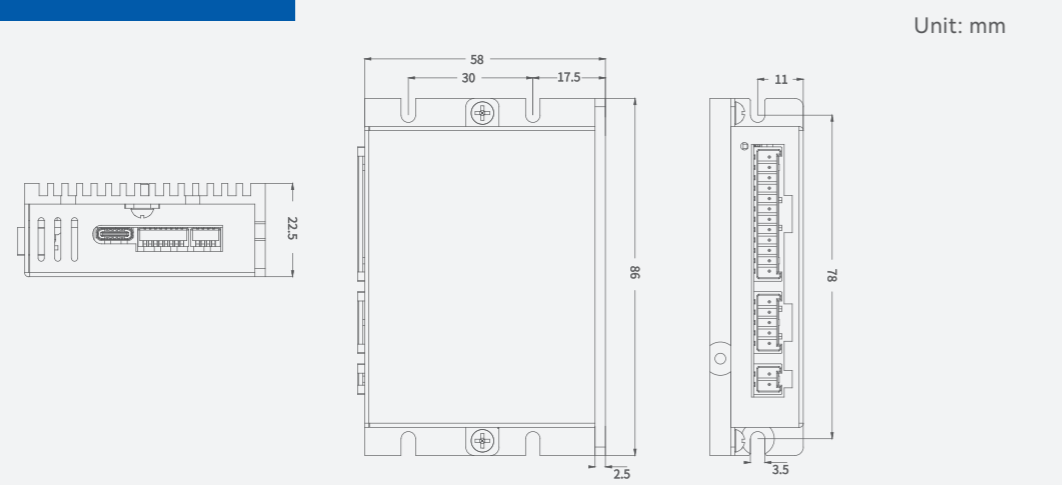

Drive	DM5-422A	DM5-432A	DM5-440A
Matching Motor	Frame 28	Frame 42	Frame 60
Power Supply	24~36Vdc	24~36Vdc	24~36Vdc
Maximum Output Current (Peak)	2.2A	3.2A	4.0A
Pulse Signal Voltage	5Vdc		
Maximum Pulse Input Frequency	1MHz		
Input Signal Current	Typical 10Ma (6~16mA)		
Input Signal Voltage	12V/24V		
Maximum OC Current	100mA		
Maximum OC Voltage	30Vdc		
Isolation Resistance	100 MΩ		

DM5-EC series

High-end 5-phase EtherCAT stepper drives

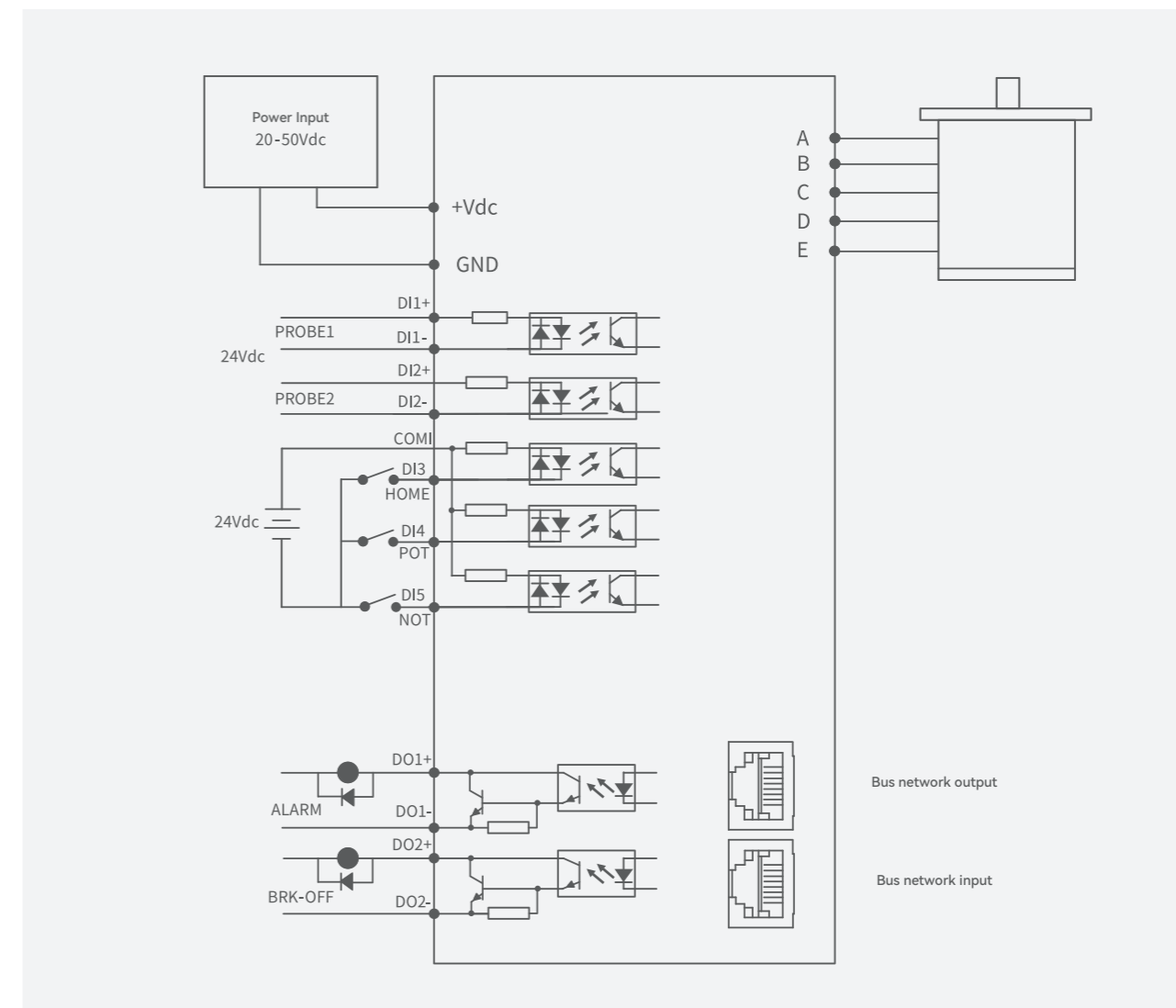
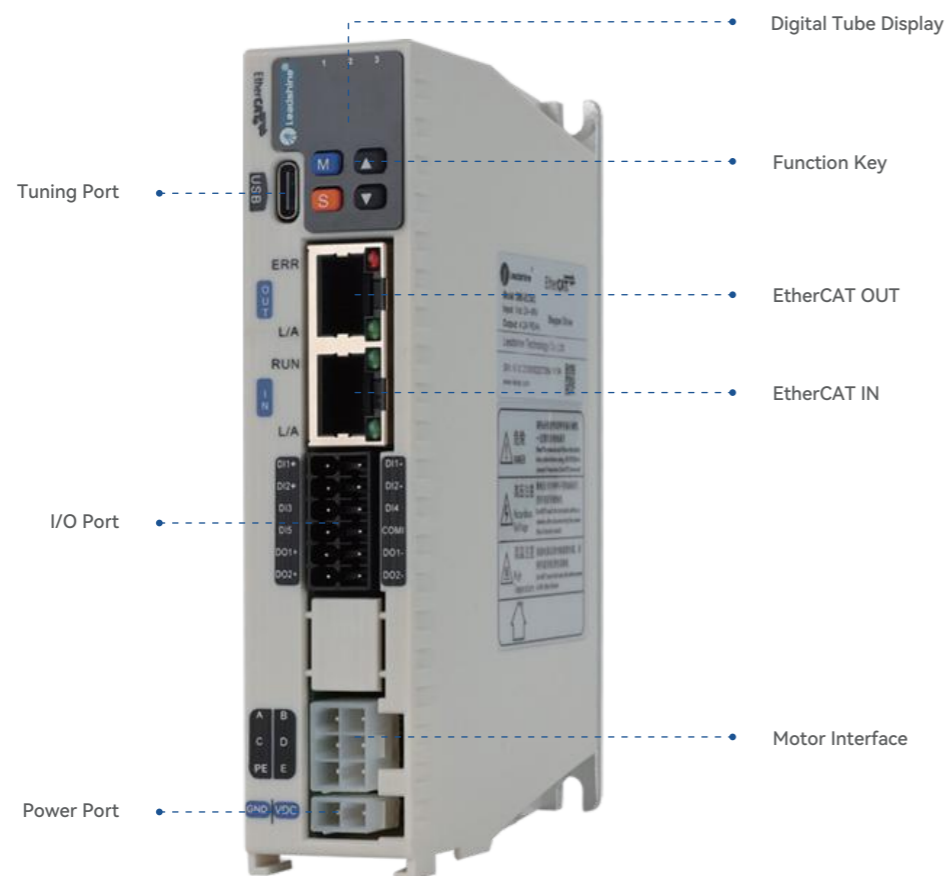

Drive	DM5-EC522	DM5-EC532	DM5-EC542
Matching Motor	Frame 28	Frame 42	Frame 60
Power Supply	20~50Vdc	20~50Vdc	20~50Vdc
Maximum Output Current (Peak)	2.2A	3.2A	4.2A
Tuning Port	TYPE-C		
Digital Input	5 DI		
Input Specification	The control signal is 12~24V, and the function supports probe input, origin, positive limit, negative limit, emergency stop, general input, etc		
Digital Output	2DO		
Output Specification	OC output, maximum pull-up 30V, maximum output 100mA, function support alarm, brake, general output, etc		
Motor winding interface	6PIN	6PIN	6PIN
power input	2PIN	2PIN	2PIN
Communication protocol standards	EtherCAT		
Control mode	CSP / PP / PV / HM		
Synchronization mdde	DC Synchronization and Free run mode		
Synchronization period	0.25~20ms		
Tuning Sostware	Motion Studio		
Isolation Resistance	100 MΩ		

DM5 Series

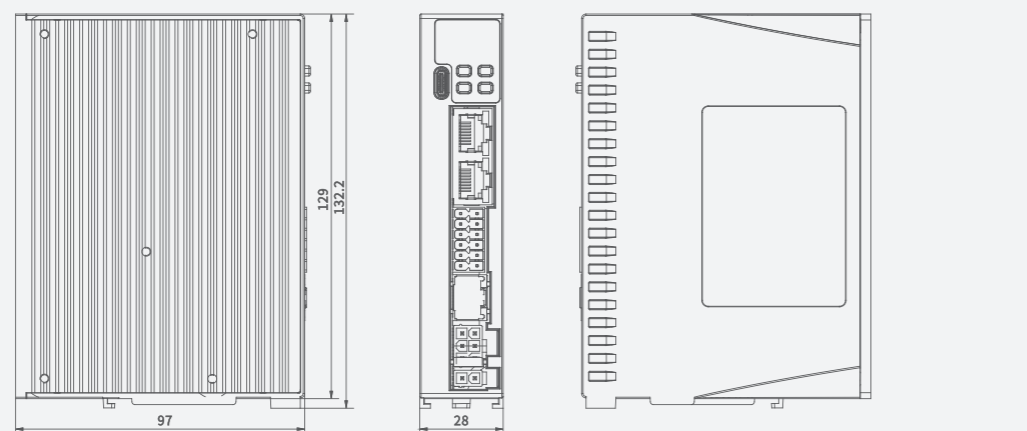

5-phase Stepper Motor

High precision and low noise



Part Numbers

60
5
CM
11

-
A

-

① Subseries Name		④ Motor Type		⑧ Standard Custom Code	
Blank	No special meaning	CM	Cost-effective open-loop stepper motor	S2	double shaft type
D	A product series that is larger than the standard mounting base			BZ	brake type
② Frame Number		⑤ Motor Torque		⑨ Regular Custom Codename	
Motor installation size code (e.g. 57 for 57 frame)		Divide by 10 is the motor holding torque (e.g., 23 means 2.3Nm)		S	Shaft extension change
③ The Number of Phases of The Motor		⑥ Design Code		L	Leadout changes
Blank	Two-phase hybrid stepper motor			F	Shaft extension belt platform
⑦ Standard Custom Code				N	optical axis
A	Current parameter			K	Shaft extension with keyway
D	Special application codes			I	Shaft diameter change
				C	Leadout with connector
				M	With synchronous wheels

Specifications

Drive	NEMA 11	NEMA 17	NEMA 24
Step angle	0.72°		
Step angle accuracy	±0.036° (no load, full step)		
Temperature rise	MAX 80K		
Use environment	Temperature: -10~+50°C; Humidity: 85%MAX		
Insulation rating	B		
Insulation resistance	MIN 100 MΩ, 500VDC		
Withstand voltage	500VAC, 1 min		
Radial runout	0.025 mm MAX (load 5N)		
Axial runout	0.075 mm MAX (load 10N)		
Maximum radial load N (10 mm from flange face)	15	30	90
Axial maximum load N	The self-weight of the motor		

NEMA 11 (28MM)



Model	Single / dual-axis	Shaft diameter (mm)	Shaft length (mm)	Length L (mm)	Rear axle diameter (mm)	Rear axle length L1 (mm)
285CM005	Single-axis	5	15	32.2	/	/
285CM005-SZ	Dual-axis	5	15	33.2	5	10
285CM012	Single-axis	5	15	51.8	/	/
285CM012-SZ	Dual-axis	5	15	52.8	5	10
863S68H	135	6.8	2.3	4.5	20	2.94

Unit: mm 1inch=25.4mm

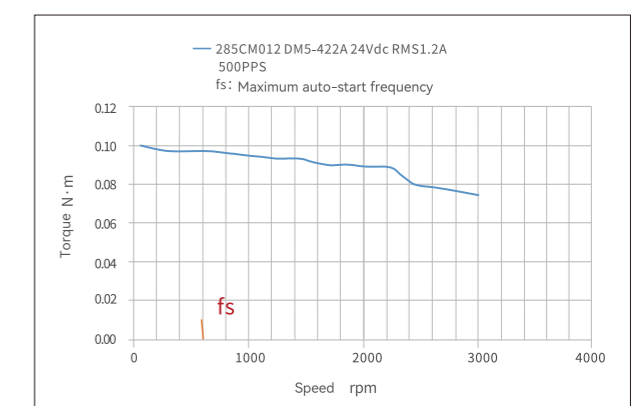
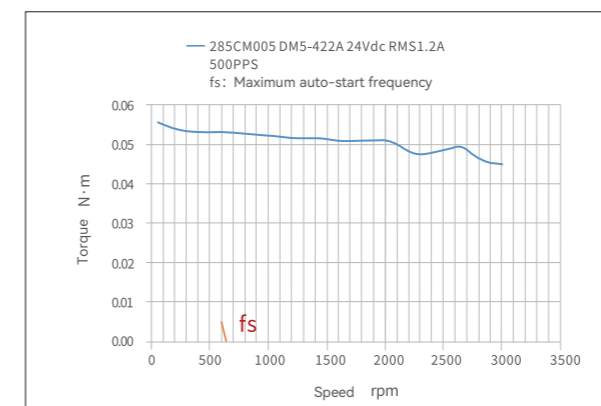
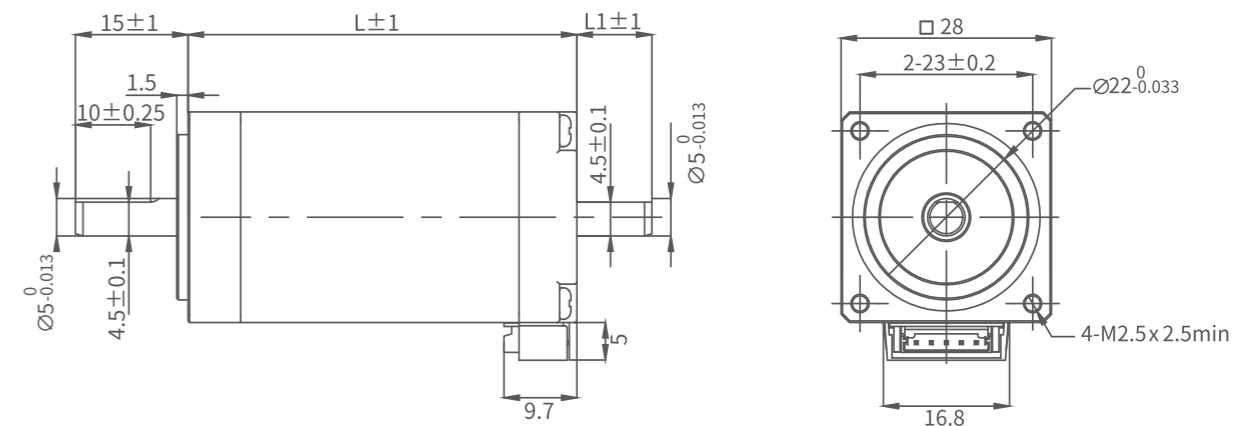

NEMA 17 (42MM)



Model	Single / dual-axis	Shaft diameter (mm)	Shaft length (mm)	Length L (mm)	Rear axle diameter (mm)	Rear axle length L1 (mm)
425CM03	Single-axis	5	20	39	/	/
425CM03-SZ	Dual-axis	5	20	39	5	15
425CM04	Single-axis	5	20	47	/	/
425CM04-SZ	Dual-axis	5	20	47	5	15
425CM05	Single-axis	5	20	59	/	/
425CM05-SZ	Dual-axis	5	20	59	5	15

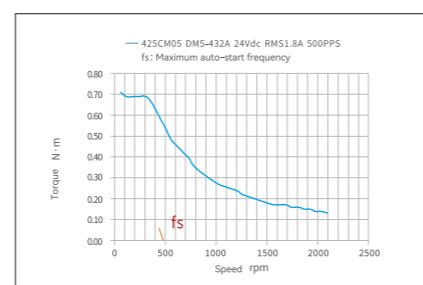
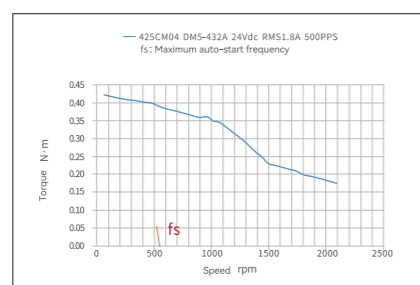
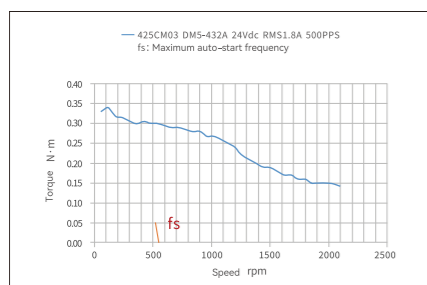
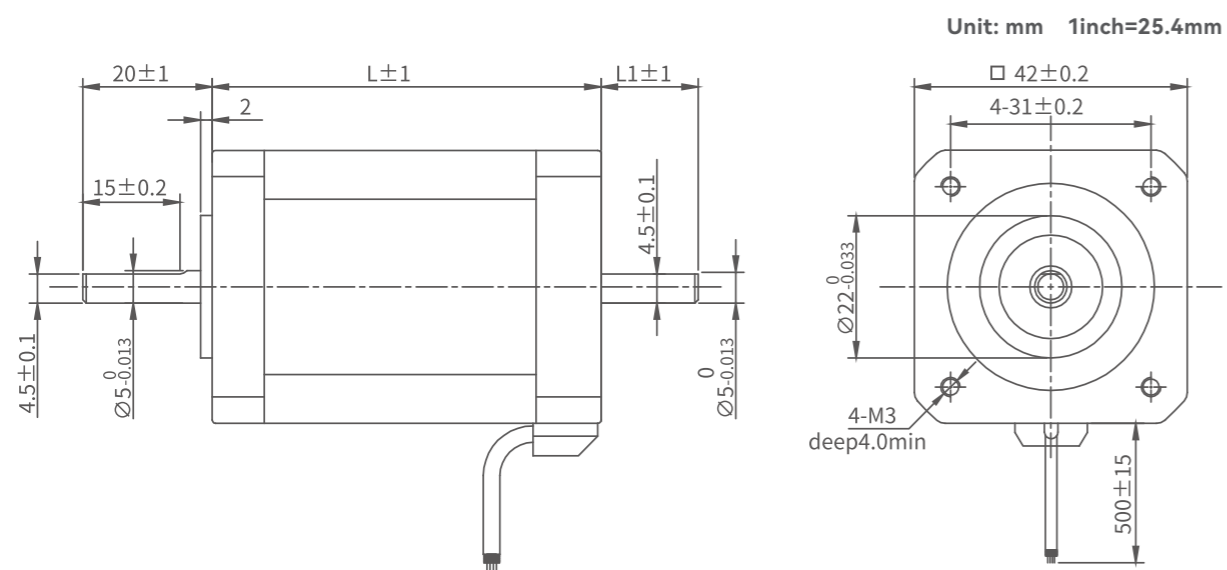

NEMA 24 (60MM)



Model	Single / dual-axis	Shaft diameter (mm)	Shaft length (mm)	Length L (mm)	Rear axle diameter (mm)	Rear axle length L1 (mm)
605CM11	Single-axis	8	21	55	/	/
605CM11-SZ	Dual-axis	8	21	55	8	21
605CM21	Single-axis	8	21	85	/	/
605CM21-SZ	Dual-axis	8	21	85	8	21

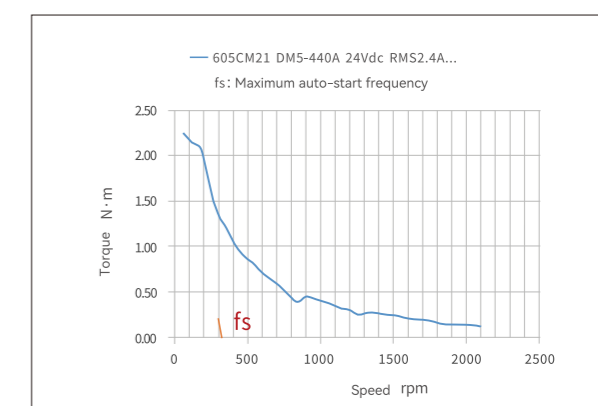
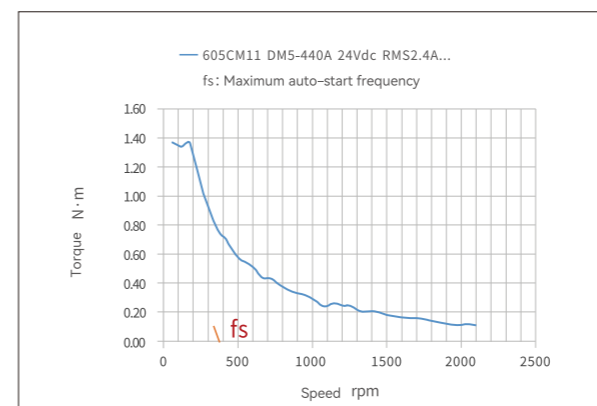
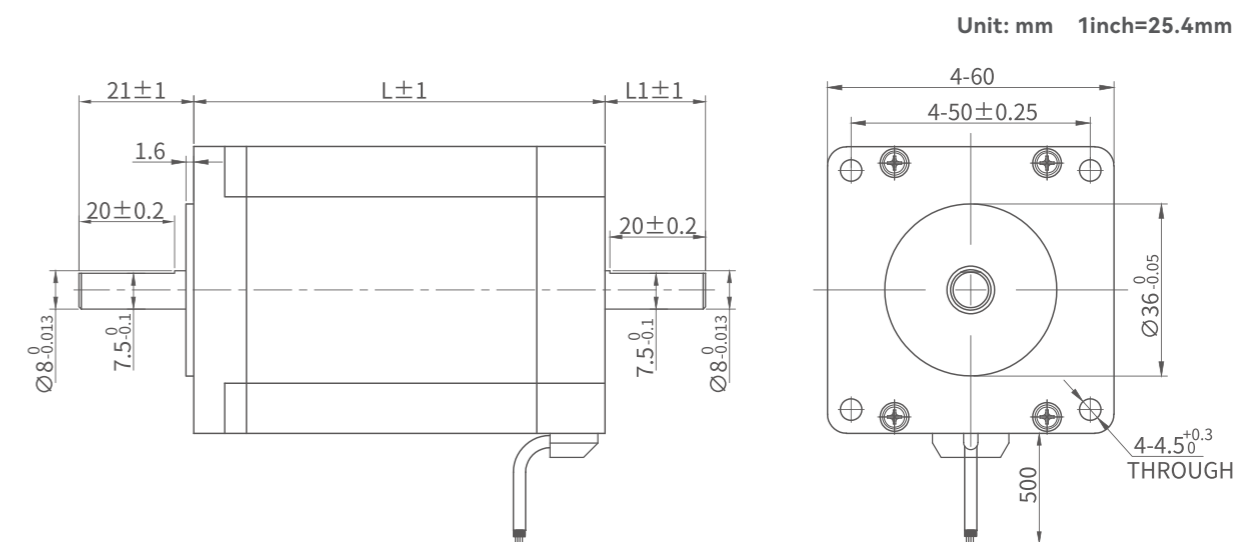

☰ Specifications

Phase/ Series	Frame size	Length (mm)	Model	Rate Current (A)	Holding Torque (N.m)	Step Angle	Resistance (Ω)	Inertia (kg·cm ²)	Weight (kg)	Matching Drive	Single/ dual-axis
5-phase/ CM	NEMA 11	32.2	285CM005	1.2	0.05	0.72°	0.56	0.009	0.1	DM5-422A	Single-axis
		32.2	285CM005-SZ	1.2	0.05	0.72°	0.56	0.009	0.1	DM5-422A	Dual-axis
		51.8	285CM012	1.2	0.12	0.72°	0.9	0.018	0.2	DM5-422A	Single-axis
		51.8	285CM012-SZ	1.2	0.12	0.72°	0.9	0.018	0.2	DM5-422A	Dual-axis
	NEMA 17	39	425CM03	1.8	0.3	0.72°	0.48	0.055	0.3	DM5-432A	Single-axis
		39	425CM03-SZ	1.8	0.3	0.72°	0.48	0.055	0.3	DM5-432A	Dual-axis
		47	425CM04	1.8	0.4	0.72°	0.55	0.071	0.38	DM5-432A	Single-axis
		47	425CM-SZ	1.8	0.4	0.72°	0.55	0.071	0.38	DM5-432A	Dual-axis
		59	425CM05	1.8	0.5	0.72°	0.64	0.11	0.49	DM5-432A	Single-axis
		59	425CM05-SZ	1.8	0.5	0.72°	0.64	0.11	0.49	DM5-432A	Dual-axis
	NEMA 24	55	605CM11	2.4	1.15	0.72°	0.38	0.29	0.75	DM5-440A	Single-axis
	NEMA 25	55	605CM11-SZ	2.4	1.15	0.72°	0.38	0.29	0.75	DM5-440A	Dual-axis
	NEMA 26	85	605CM21	2.4	2.1	0.72°	0.64	0.54	1.2	DM5-440A	Single axis
	NEMA 27	85	605CM21-SZ	2.4	2.1	0.72°	0.64	0.54	1.2	DM5-440A	Dual-axis

Closed Loop Stepper Drive Part Numbers

CS □ - D □ 50 7 - □

Series Name	
CS	New Series
ES2	Vector Control Series
ES	Classical Series

Control Mode	
3E-	EtherCAT Control
2RS-	Rs485 Modbus RTU
1 or Blank	Pulse Control

Product Type	
D	Drive

AC or DC	
Blank	DC
A	AC (except ES-DH1208 and ES-DH2306)

Grade	
Blank	Standard
E	Economic
S	High Performance

Max Peak Current	
3: 3.0A	7: 7.0A
6: 6.0A	8: 8.0A

Max Power Voltage	
50	50V
80	80V
100	100V±10%
120	120V±10%
230	Single-phase 230V±10%

Closed Loop Stepper Motor

CS - M 2 34 85 □ - □

Series Name	
CS	New Series
ES2	Special Series
ES	Classical Series

Product Type	
M	Low or Medium Voltage Motor
MH	High Voltage Motor

2 or 3 Phase Motor	
2	2-phase Motor
3	3-phase Motor

Series Name	
08	NEMA 8 (20mm)
11	NEMA 11 (28mm)
17	NEMA 17 (42mm)
23	NEMA 23 (57mm)
24	NEMA 24 (60mm)
34	NEMA 34 (86mm)
42	NEMA 42 (110mm)

Customized	
Blank	1000 ppr Encoder
E2Z	2500 ppr Encoder
E5Z	5000 ppr Encoder
S	Inch Diameter (6.25mm or 12.7mm)
L	Large NEMA 23 motor

Standard Customized Spe.	
Blank	Standard
B	Brake
WP	Waterproof (Rate IP65)

Holding Torque	
013: 0.13N.m	30: 3.0N.m
02: 0.2N.m	31: 3.1N.m
06: 0.6N.m	45: 4.5N.m
08: 0.8N.m	80: 8.0N.m
13: 1.3N.m	85: 8.5N.m
23: 2.3N.m	120: 12N.m
26: 2.6N.m	200: 20N.m



2CS3EIP Series \ 2CS3E Series

Fieldbus Closed Loop Stepper Drives

- Support EtherCAT(EtherNet/IP) fieldbus
- Matching most of master controller
- No loss of step, Excellent performance

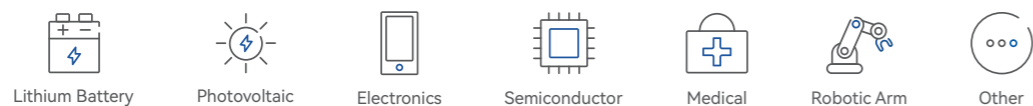

Overview

○ EtherCAT(EtherNet/IP) Communication

- Support EtherNet/IP communication.
- Support great majority of master station such as Beckhoff, Omron, KEYENCE, Panasonic etc.
- Support position, velocity, and homing control mode.

○ More Efficient by Dual-axis Control

- One drive controls two axes via one IP address, highly reduce communication load rate.
- Two axes are independently controlled.

○ STO Optional

- Safe torque off (STO) ensure the safety system.

○ Saving Cost

- One dual-axis drive is more economy than two single-axis drives.

○ Saving Mounting Space

- 10% thickness reducing compared to one single-axis drive.
- 50% at least mounting space saving compared to two single-axis drives.

○ Closed-loop control

- Without losing steps in high speed operation.
- Encoder resolution: 1000 / 2500 / 5000 line for NEMA11/17/23/24/ 34 CS motors.

Specifications

Models	Operating Voltage	Output Current (A)	Matching Motor	Weight (kg)	Dimension (mm)
2CS3EIP-D503	20-50VDC	0.5-2.2	NEMA8/11/14/17	0.4	155*116.5*28
2CS3EIP-D507	20-50VDC	1.0-5.6	NEMA17/23/24	0.4	155*116.5*28
2CS3E-D503	20-50VDC	0.5-2.2	NEMA8/11/14/17	0.4	155*116.5*28
2CS3E-D507	20-50VDC	1.0-5.6	NEMA17/23/24	0.4	155*116.5*28
Termination Resistor	The last node needs to add the terminal resistance generally				
Tuning cable	CABLE-USB1M5				
CABLE-TX*M*-BUS	Network Cable: 0.1m, 0.2m, 0.3m, 0.4m, 1m, 1.5m, 2m, 3m,5m,7m, 10m,15m, 20m				

2CS3EIP Series \ 2CS3E Series

Unit: mm

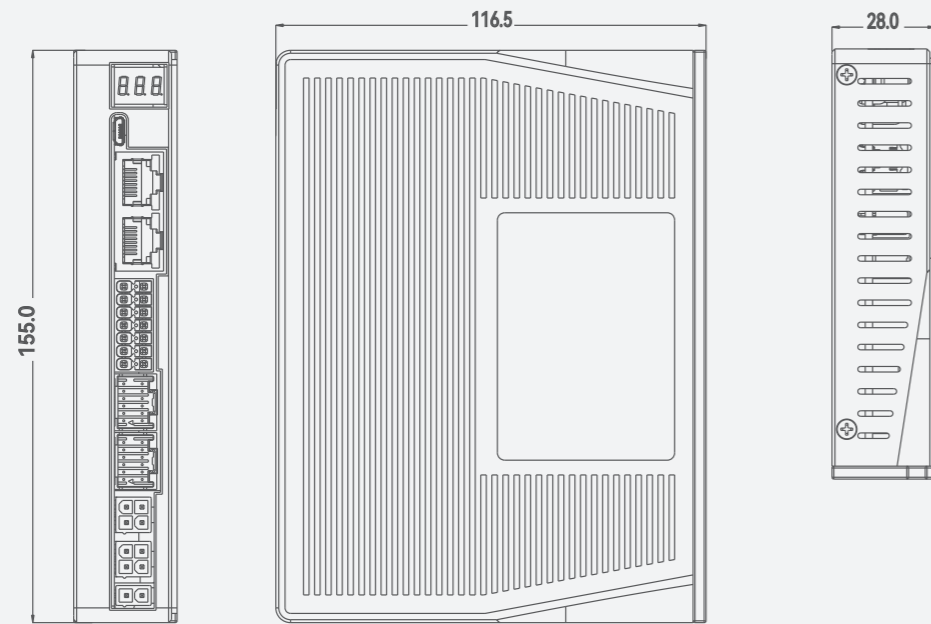

Drive Wiring Diagram

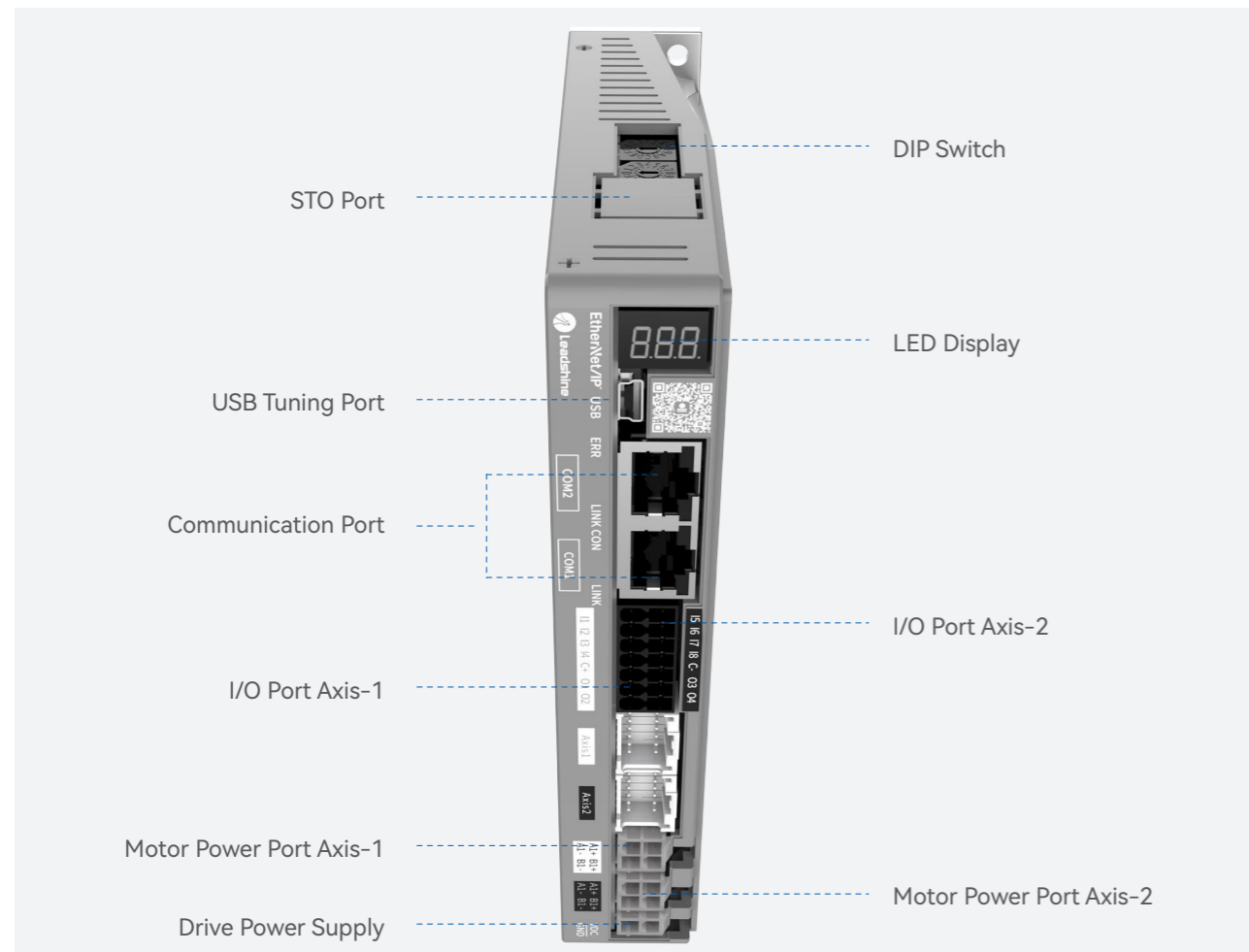
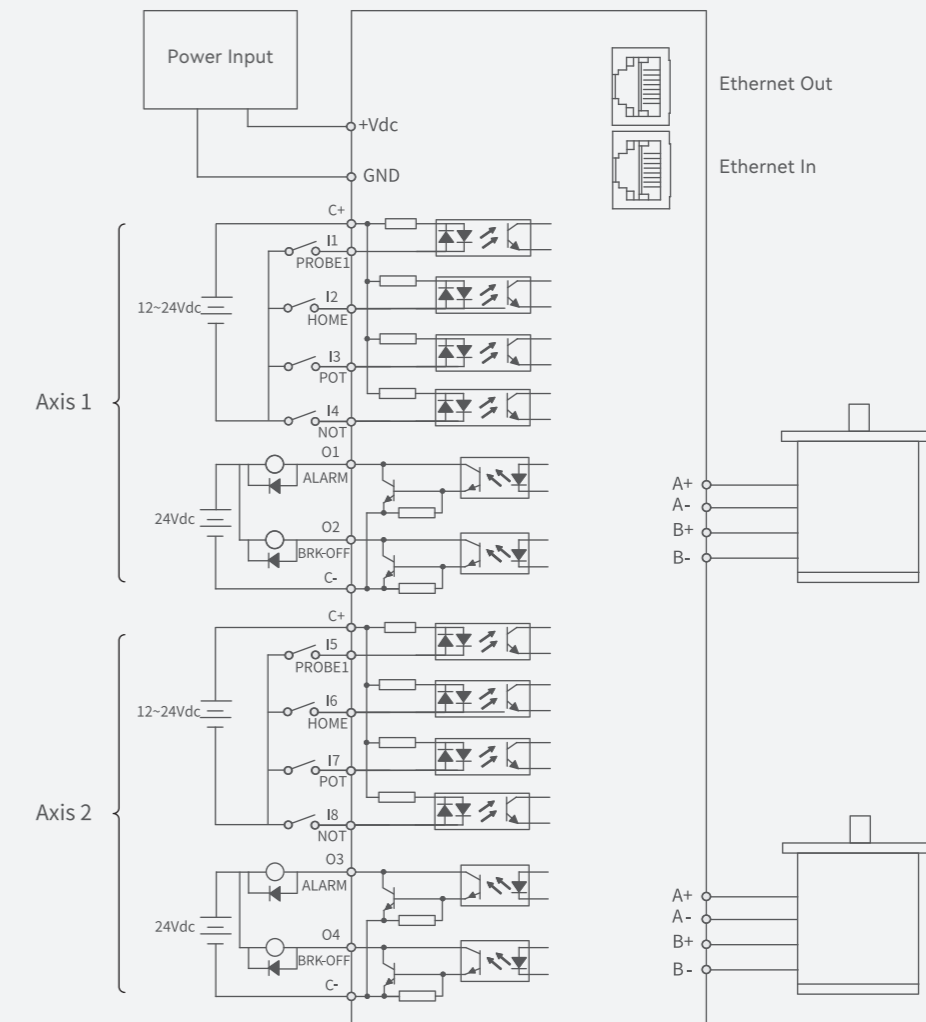



CS3E Series

Fieldbus Closed Loop Stepper Drives

- Support CoE control and CiA 402 protocol
- Matching most of master controller
- Conformance tested by ETG
- No loss of step, Excellent performance

The CS3E series drives support operating modes: Cyclic Synchronous Position (CSP), Profile Position (PP), Profile Velocity (PV), Homing(HM). The products can be matched with most of EtherCAT controller/PLC such as Beckhoff, Omron, Trio, etc.

They have excellent performance including enhanced reliability, super-low noise, anti-resonance, low-speed ripple smoothing and remains 40% less cost than network servo at least. Can power 2-phase NEMA8,11, 14, 17, 23, 24 and 34 stepper motors with incremental encoder in many industrial applications such as CNC, medical, electronics, packaging...

Overview

- No loss of step, No hunting, No torque reservation.
- CS3E support standard EtherCAT protocol with operation modes of PP, PV, CSP, HM.
- 7 configurable digital inputs, 7 optically isolated digital outputs include brake output.
- USB port for parameters configuration.
- Two 7-segment display velocity or slave ID or operation mode or error code.
- Encoder resolution: 1000 / 5000 line for NEMA11/14/17/23/24/ 34 CS motors.
- Thickness reduce to 28mm, more benefit for mounting.
- Friendly type-C tuning port.
- Improve network anti-interference ability.
- Protections for over-voltage, over-current and position following error, encoder wiring error, etc.

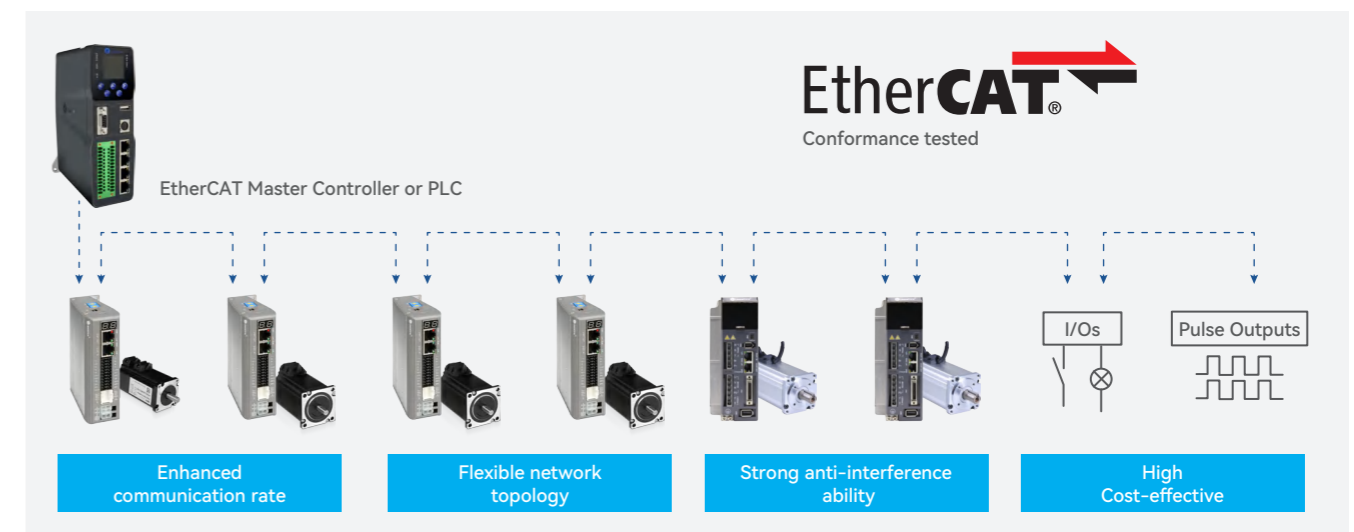

Specifications

Models	Operating Voltage	Output Current (A)	Matching Motor	Weight (kg)	Dimension (mm)
CS3E-D503B	20-50VDC	0.1-3.0A	NEMA8/11/14/17	0.28	118*90*28
CS3E-D507B	20-50VDC	0.1-7.0A	NEMA17/23/24	0.28	118*90*28
CS3E-D1008	20-80VAC or 30-100VDC	0.5-8.0A	NEMA34	0.85	151*97*52
Tuning Cable	CABLE-TYPEC2M0				
CABLE-TX*M*-BUS	Network Cable: 0.1m, 0.2m, 0.3m, 0.4m, 1m, 1.5m, 2m, 3m,5m,7m, 10m,15m, 20m				
CABLEM-BM*M*	Encoder Extension Cable				
CABLEM-RZ*M*	Motor Extension Cable				

CS3E Series

Unit: mm

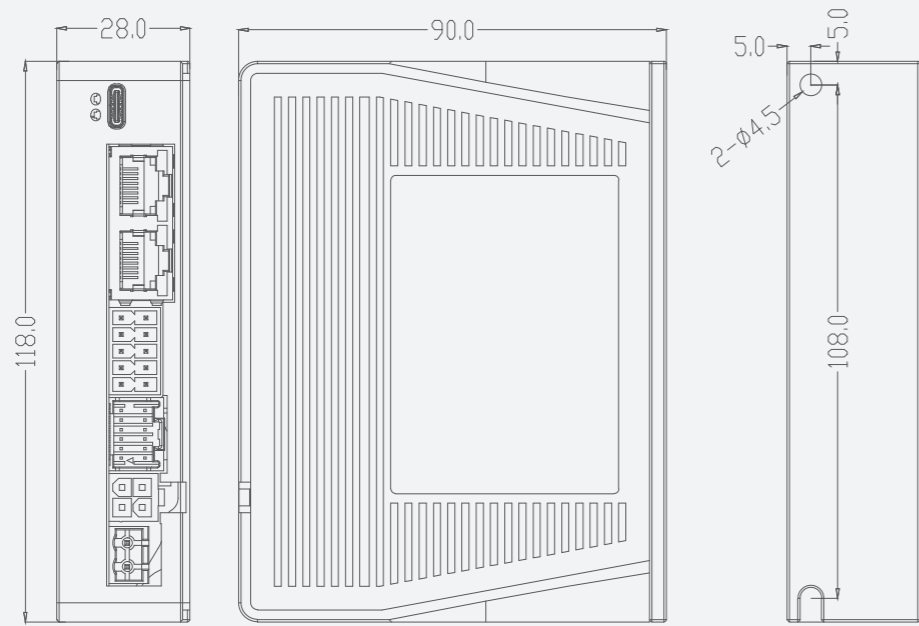

Node Address Dip-switch

USB Tuning Port

EtherCAT OUT

EtherCAT IN

I/O Port

Motor Power Line Port

Power Input Port



Drive Wiring Diagram

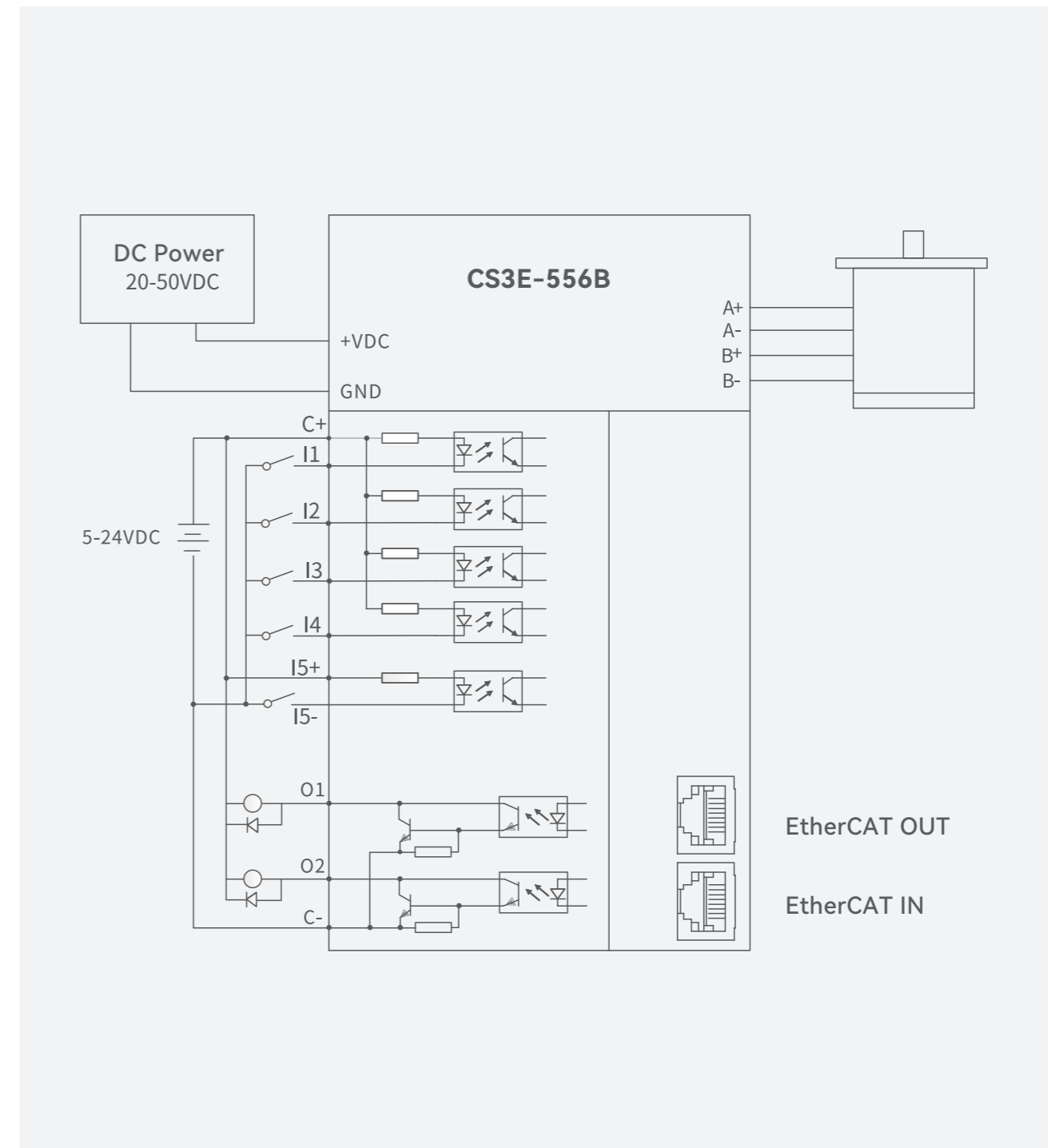



CS2RS Series

Fieldbus Closed Loop Stepper Drives

- Standard Isolated RS485 Modbus
- No loss of step & smooth motion
- Built-in Uni-axial Control Instruction
- HMI, PLC or External I/O start motion

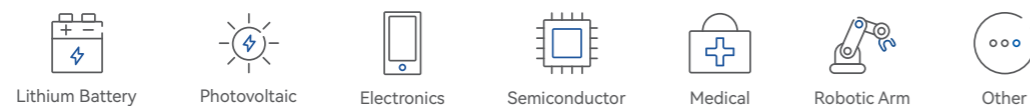

Overview

7 Programmable Inputs

- Limit + / - or Origin inputs
- Quick stop, Alarm reset and Enable inputs
- JOG + / - or Position Table inputs

3 Programmable Outputs

- Alarm, Brake outputs
- Homing / Instruction / Path complete

Modes of Operation

- Velocity
- Position
- Homing

Support Functions

- Teaching
- Interrupt
- Skip, Suspend, Circulate motion

PC Software for Easy Setup, Fine Tune, Matching Motors

- NEMA8, 11,17, 23, 24, 34
- Standard, dual shaft, brake, waterproof

Support RS485 communication

- Adopted closed loop step system to make real-time position error correction ,can eliminate potential loss of step.

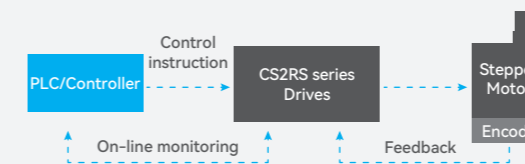

Built-in uni-axial control instruction

- Programmable 16-segment position table, support positioning / homing / limit / quick stop / JOG...

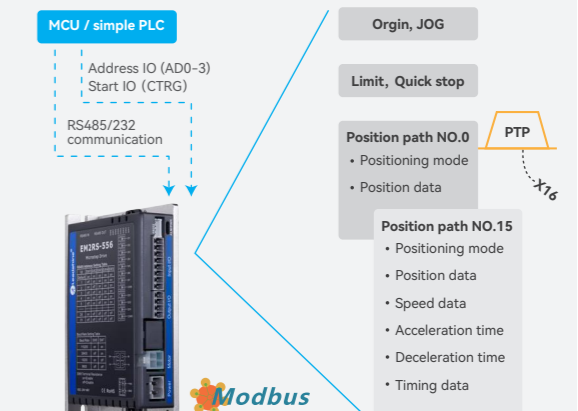

Support RS485 communication

- Standard Modbus RTU protocol, RS485 communication can network up to 31 axes

Method1:HMI control Method2:Simple PLC control

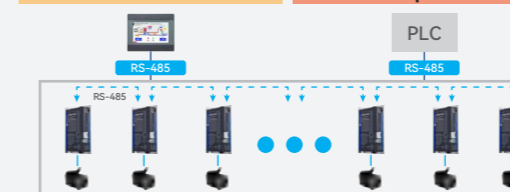

Specifications

Models	Operating Voltage	Output Current (A)	Matching Motor	Weight (kg)	Dimension (mm)
CS2RS-D503	20-50VDC	0.5-3.0	NEMA8/11/14/17	0.38	116*69.2*26.5
CS2RS-D507	20-50VDC	0.5-7.0	NEMA17/23/24	0.38	116*69.2*26.5
CS2RS-D1008	20-80VAC or 30-100VDC	0.5-8.0	NEMA24/34	0.57	151*97*53
Tuning Cable	CABLE-PC-1				
CABLEM-BM*M*	Encoder Extension Cable				
CABLE-TX*M*-BUS	Motor Extension Cable				



CS1 Enhanced Version CS Cost-effective Version

Pulse Control Closed Loop Stepper Drives

CS1 Series----Enhanced Performance

Overview

- New generation of algorithm
- Noise reduction improved by 20db
- Vibration reduction improved by 30%
- Temperature rise reduction improved by 20°C

Inputs and Outputs

- Step & DIR (CW & CCW) inputs
- Alarm output and In Position output
- Encoder A/B/Z outputs
- Enable input and Error Reset input
- Brake outputs

Switch Settings

- Microstep resolution
- Pulse Mode
- Closed / Open Loop Mode
- Gain adjustment and output current
- Rotation direction
- Positional command filter
- Encoder resolution
- 5V or 24V signal voltage optional

Specifications

Items	CS1-D503S		CS1-D507S		CS1-D728S	
	Min	Max	Min	Max	Min	Max
Output Current (A)	0.5	3	0.5	7	0.5	8
Power Voltage (VDC)	20	50	20	20	20	72
Input Frequency (kHz)	-	500	-	500	-	500

Closed Loop Stepper Motors and Drives

Pin Assignments

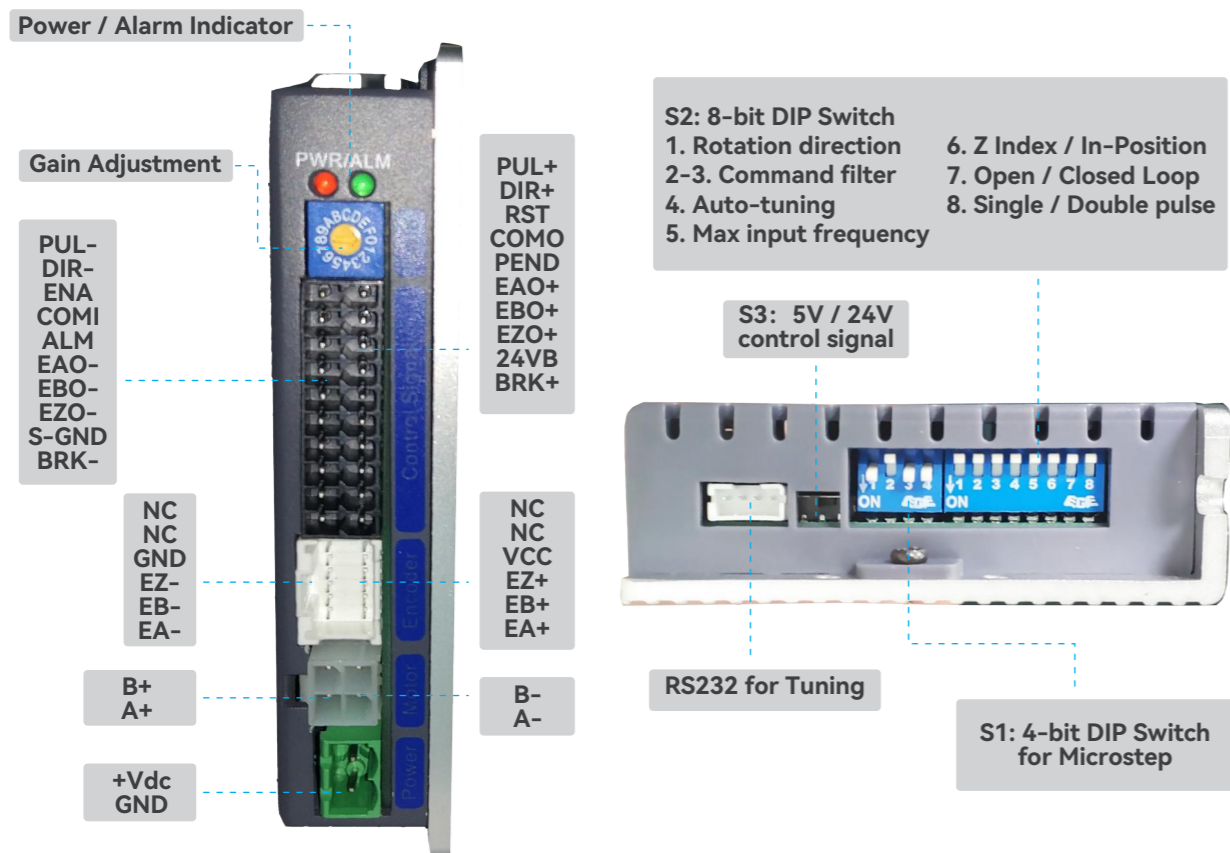

CS Series----Cost-effective Version

The CS series consists of ES seasy servo drives adopting Leadshine latest advanced closed loop control technology. Those drives are highly reliable with good performance and highly competitive cost. They can power a wide range of closed loop stepper motors from NEMA 8 to NEMA 34 (model dependent) with incremental encoders. CS series drives are easy to configure and setup.



Model	CS-D508	CS-D808	CS-D507E	CS-D1008E
Operating Voltage	20-50 VDC	20-80 VDC	20-50 VDC	20-80VAC or 30-110VDC
Peak Output Current	0.5-7.0A	0.5-8.0A	0.5-7.0A	0.5-8.0A
Control Signal Voltage	5V		5/24V	
Max. Input Frequency	200KHz (500kHz optional)			

CS Series

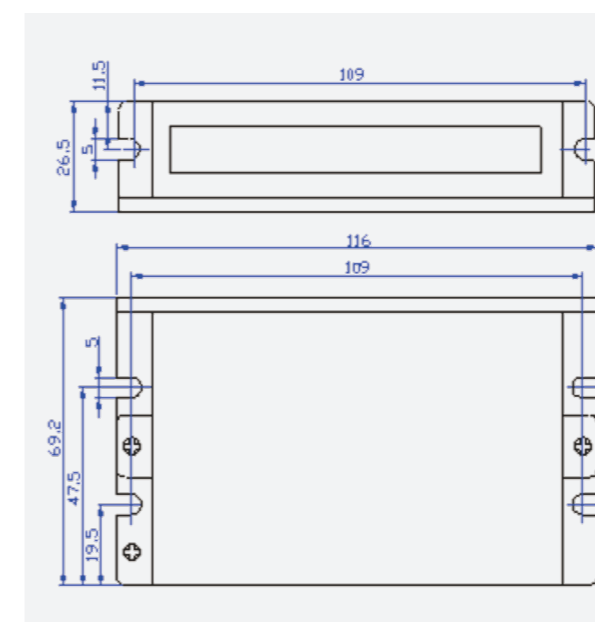
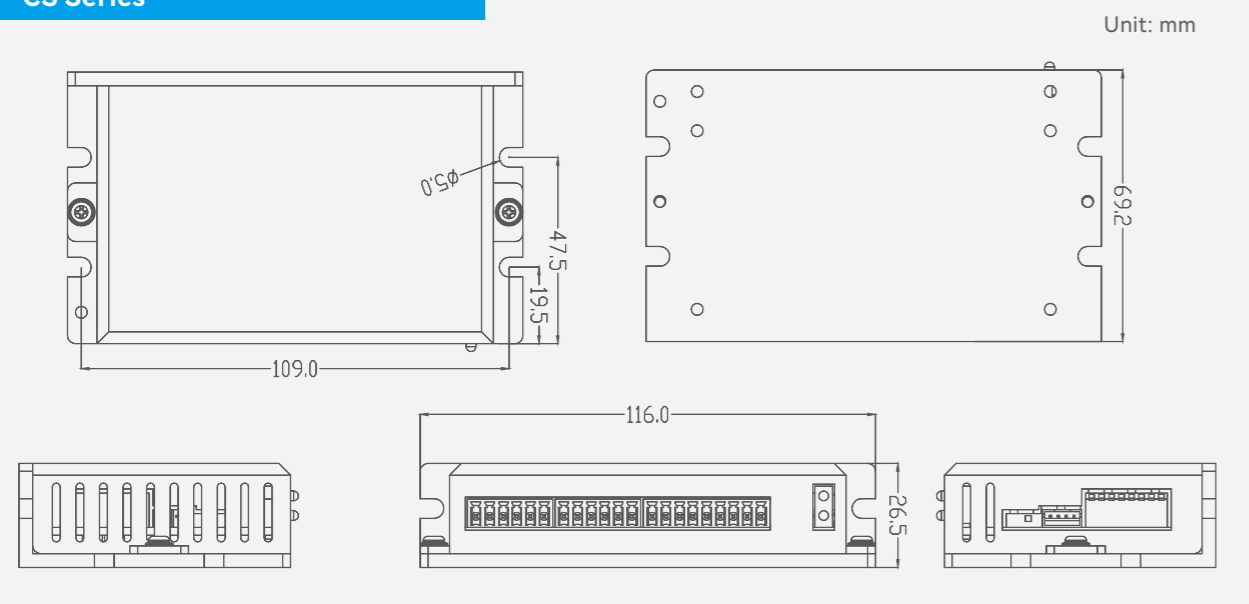

CS-D508 / CS-D507E

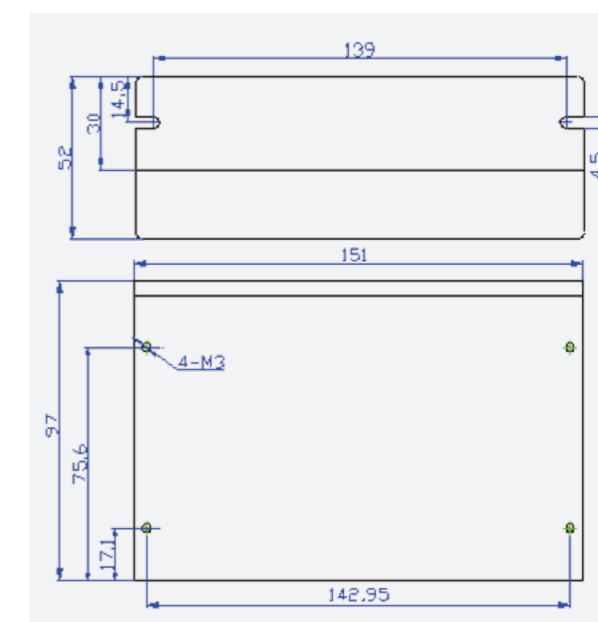

CS-D808 / CS-D1008E



Closed Loop Stepper Motors

CS-M Series

- Replace ES-M series easy servo motor
- Frame size of NEMA 8 to 34
- High reliability and high precision
- Reliable encoder solution

Introduction

CS-M series closed loop stepper motor integrated the cm series stepper motor and encoder, which can provide large torque, low heat and reliable position feedback signals. CS-M series also includes the types with brake, waterproof and different resolution. As a result of large-scale automated production lines and strict quality management system, CS-M series motors are more stable, reliable, superior, consistent and has a lower lost.

Most of ES-M easy servo motors will be replaced by CS-M motors.

Encoder Specifications

Encoder Resolution	1000 ppr, 2500 ppr, 5000 ppr
Encoder Current	Typical 56mA / Max. 59mA
Low Level	0.4v@20mA Max
High Level	2.4v@-20mA Min

Motor Specifications

Step Angle	1.8°
Position Accuracy	±0.09°
Temp Rise (Max.)	Max. 85K
Operation Environment	Temperature: -10°C ~ +50°C; Humidity: Max. 85%
Insulation Class	B
Insulation Resistance	Min.100 MΩ, 500 V DC
Dielectric Strength	500 VAC, 1 min
Radial Play	0.025 mm Max. (Load 5N)
Axial Play	0.075 mm Max. (Load 10N)

Installation & Operation Conditions

Motor Size	NEMA17	NEMA23	NEMA24	NEMA34
Store Temperature	-10°C ~ +50°C			
Store Humidity	Max. 85%			
Operation Environment	Non-corrosive gas and dust; No direct contact with water, oil (except the waterproof type)			
Radial Load(N) (Distance to the flange 10mm)	30	75	90	300
Axial Load(N)	Less than motor weight			

NEMA 17 (42mm)



Models	Length (mm)	Holding Torque (N.m)	Rate Current (A)	Inertia (kgm ² *10 ⁻⁴)
CS-M21702	56	0.2	1.5	0.023
CS-M21704	63	0.4	1.5	0.045
CS-M21706	70	0.6	2.5	0.077
CS-M21708	83	0.8	2.5	0.11

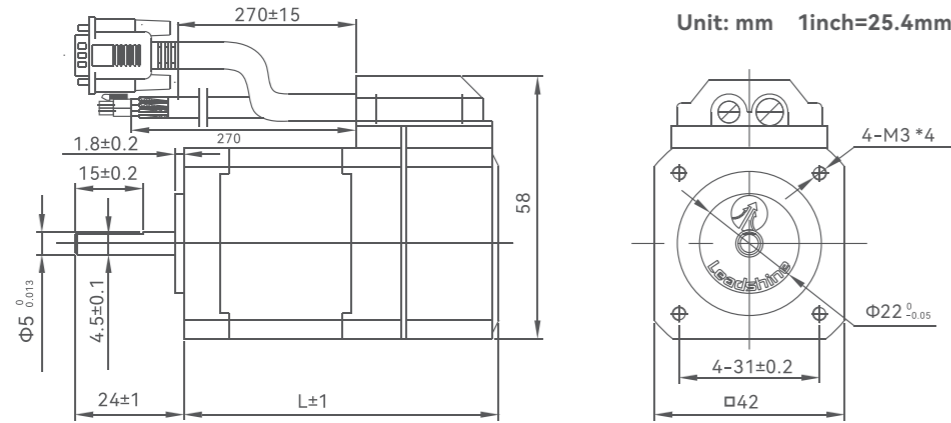

NEMA 23 (57mm)



Models	Length (mm)	Holding Torque (N.m)	Rate Current (A)	Inertia (kgm ² *10 ⁻⁴)
CS-M22306	60	0.6	3.0	0.131
CS-M22313	75	1.3	4.0	0.3
CS-M22323	95	2.3	5.0	0.48
CS-M22326	103	2.6	5.0	0.7

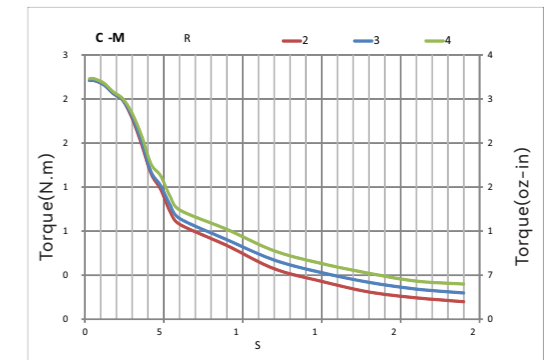
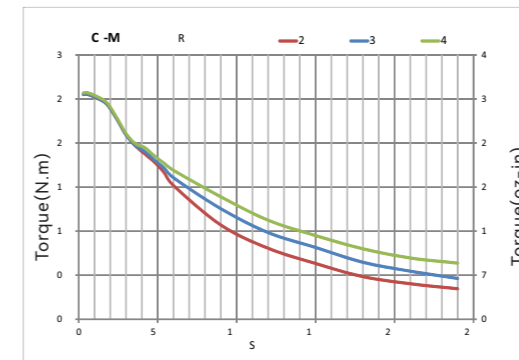
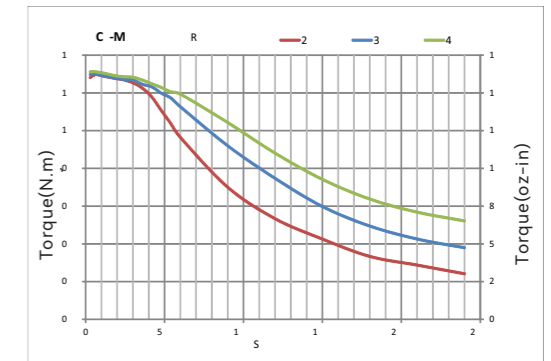
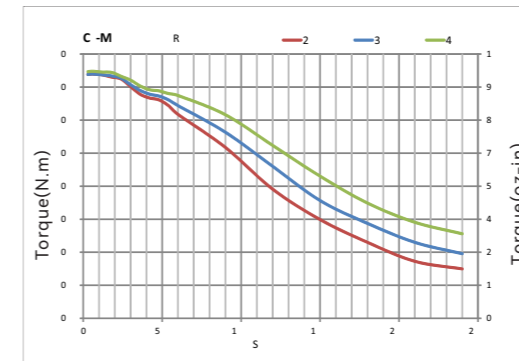
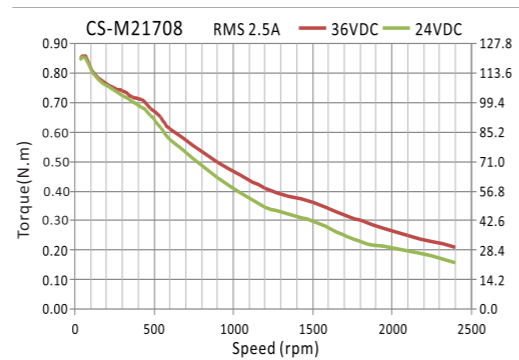
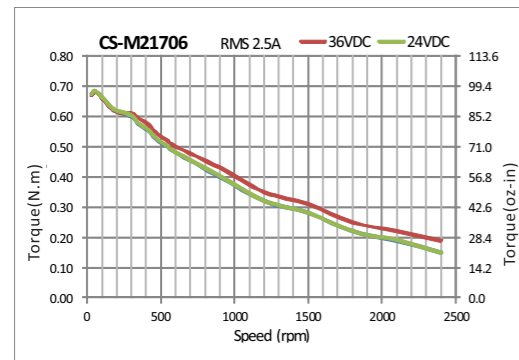
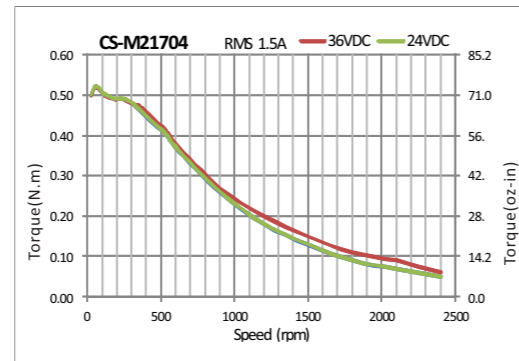
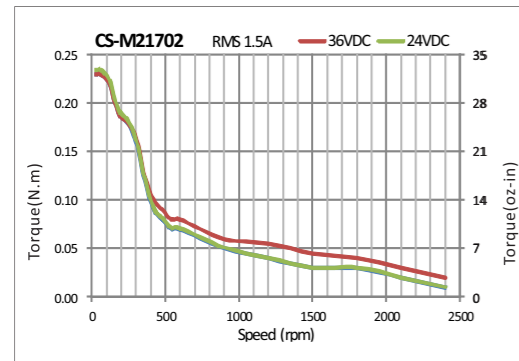
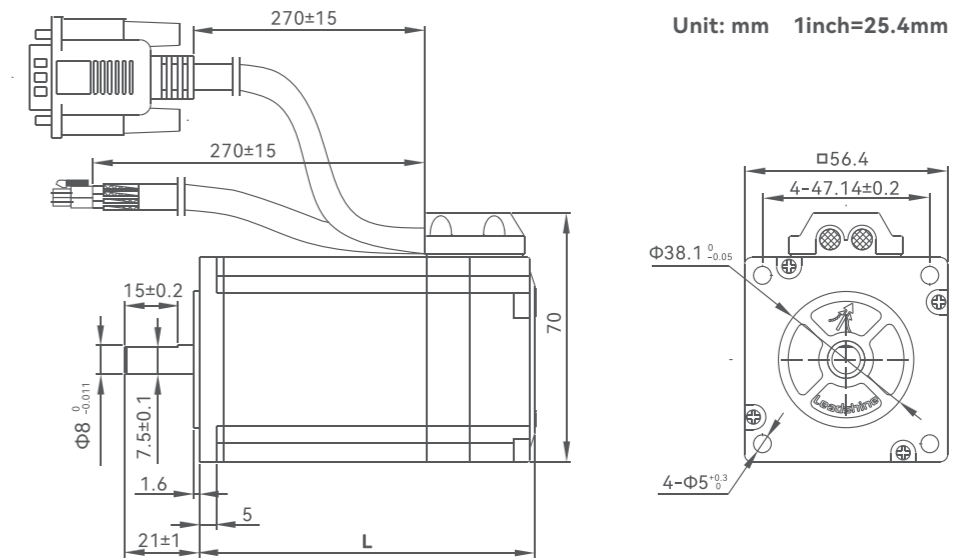

NEMA 23 (57mm)



Models	Length (mm)	Holding Torque (N.m)	Rate Current (A)	Inertia (kgm ² *10 ⁻⁴)
CS-M22321-L	86	2.1	5.0	0.49
CS-M22331-L	105	3.1	5.0	0.69

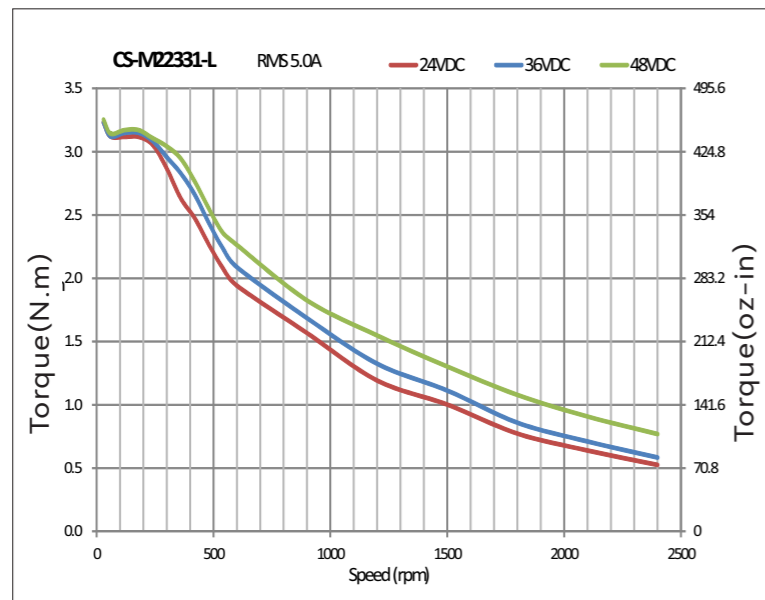
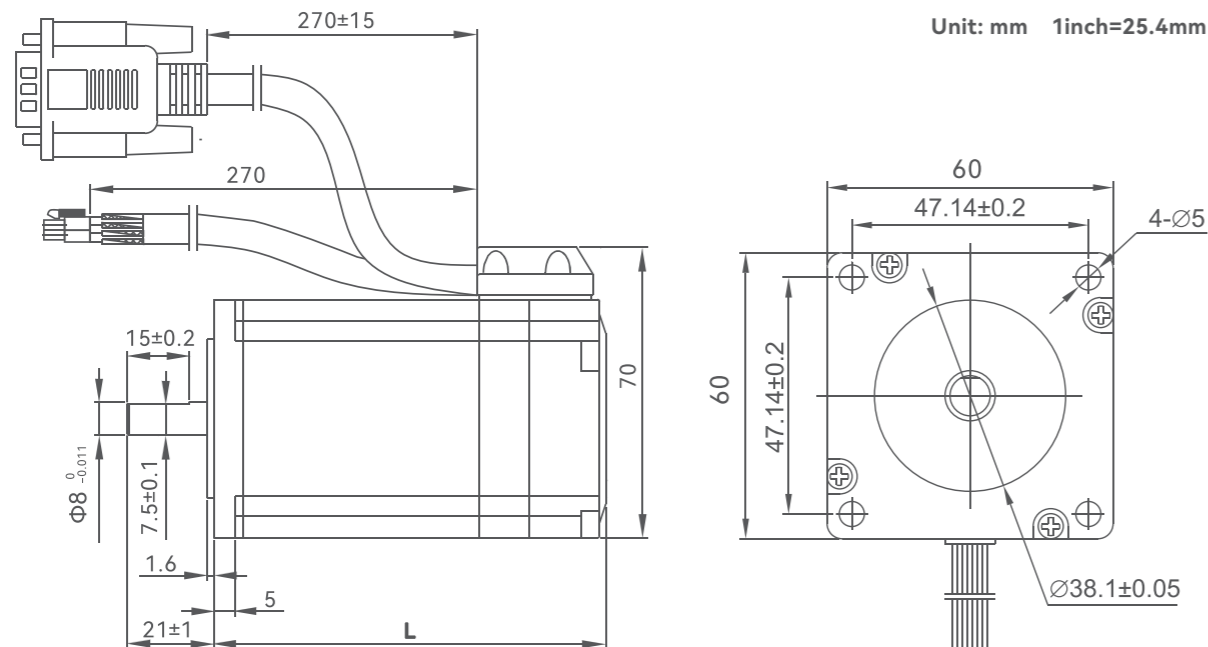

NEMA 24 (60mm)



Models	Length (mm)	Holding Torque (N.m)	Rate Current (A)	Inertia (kgm ² *10 ⁻⁴)
CS-M22422	86	2.2	5.0	0.49
CS-M22430	103	3.0	5.0	0.69

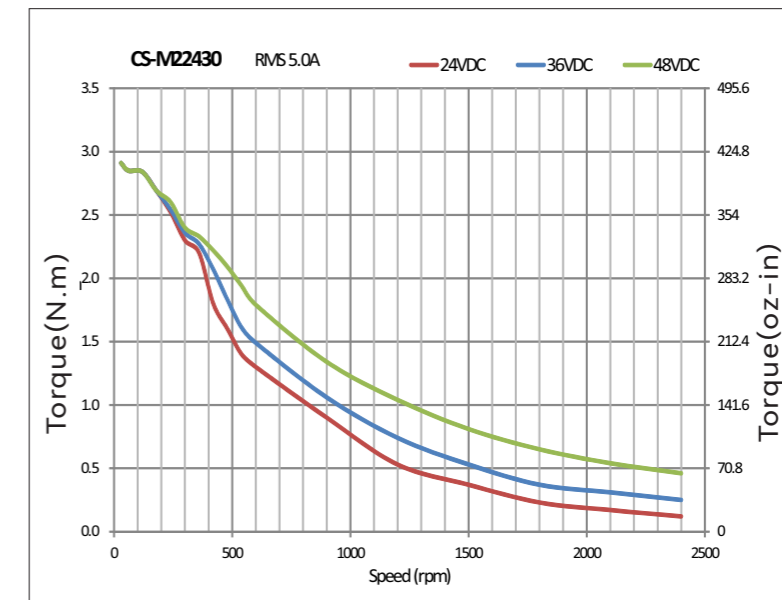
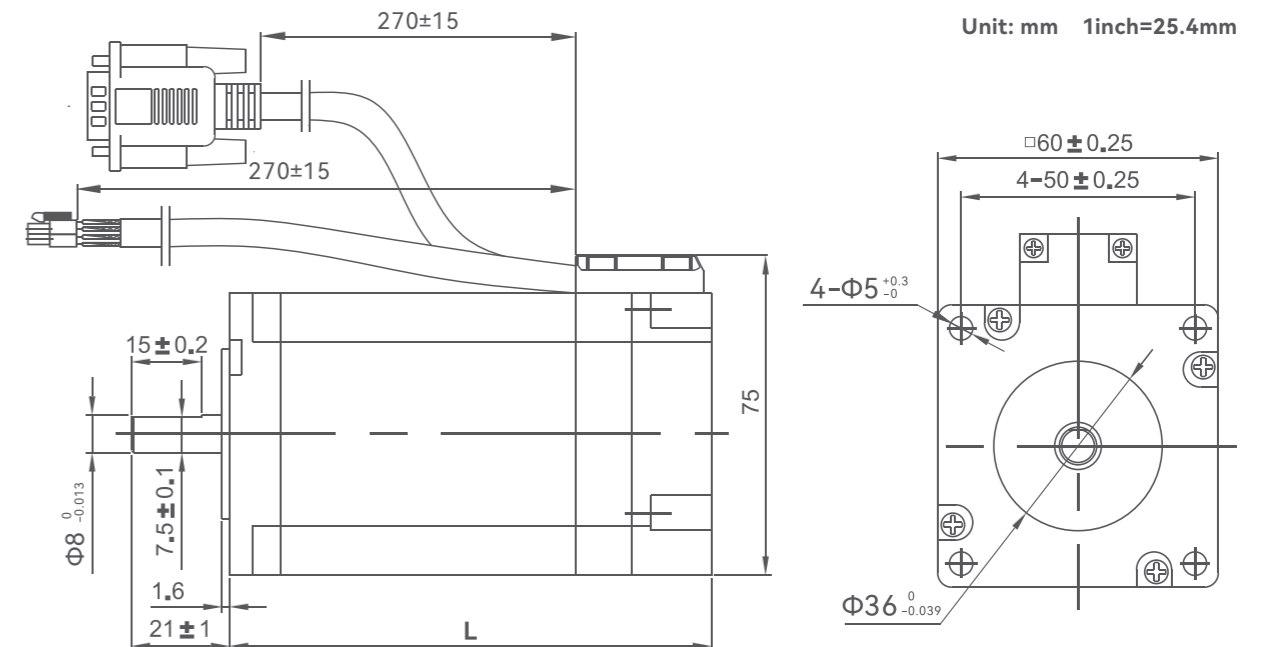

NEMA 34 (86mm)



Models	Length (mm)	Holding Torque (N.m)	Rate Current (A)	Inertia (kgm ² *10 ⁻⁴)
CS-M23435	95	3.5	4.0	1.0
CS-M23445	109	4.5	6.0	1.95
CS-M23480	127	8.0	6.0	2.5
CS-M23485	147	8.5	6.0	2.8
CS-M234120	158	12.0	6.0	3.0

Note: Motors with 1/2 in(12.7mm) shaft diameter are available.

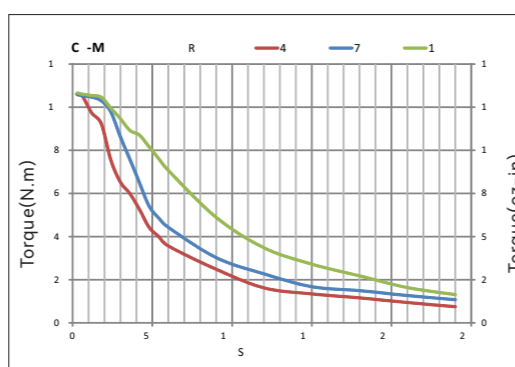
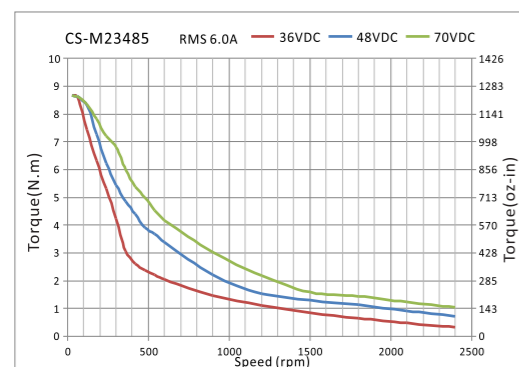
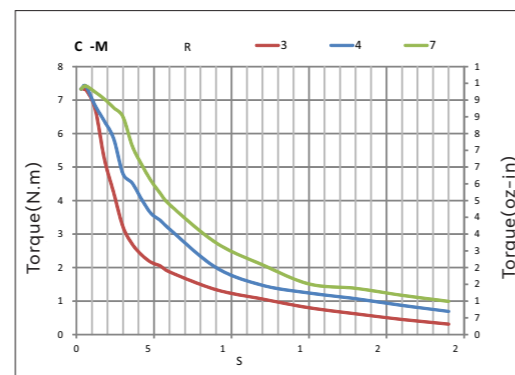
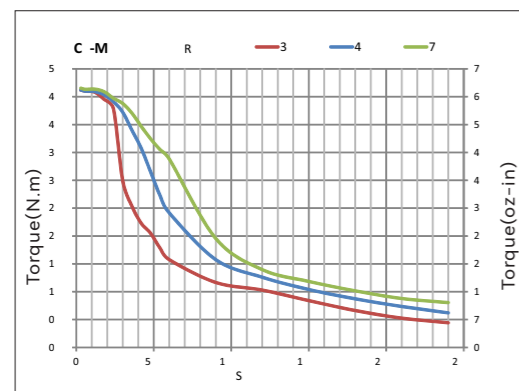
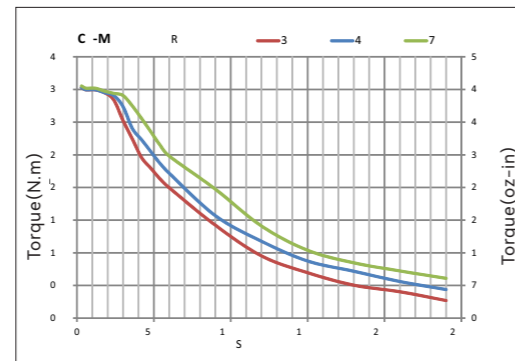
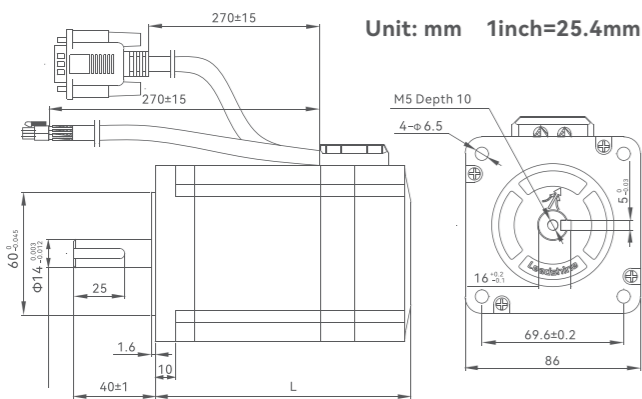

3-phase: NEMA 34, 42



Models	Length (mm)	Holding Torque (N.m)	Rate Current (A)	Inertia (kgm ² *10 ⁻⁴)
ES2-MH33480	158	8.0	6.0	3.0
ES2-MH334100	185	10.0	6.0	3.0
ES2-MH342120	162	12.0	4.2	10.8
ES2-MH342200	244	20.0	5.2	17

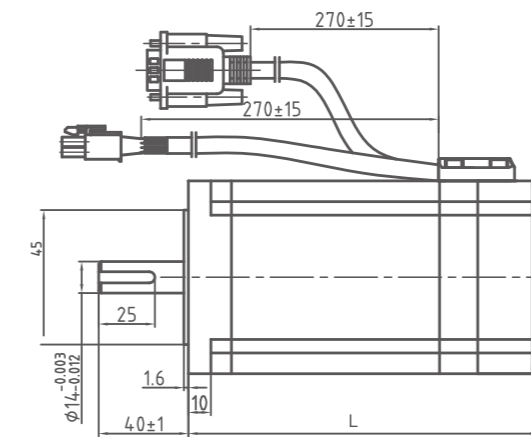

Unit: mm 1inch=25.4mm

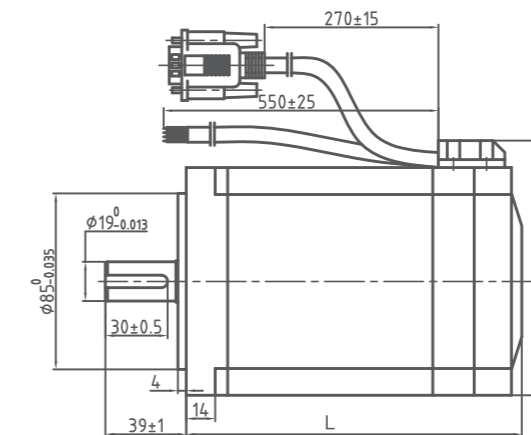
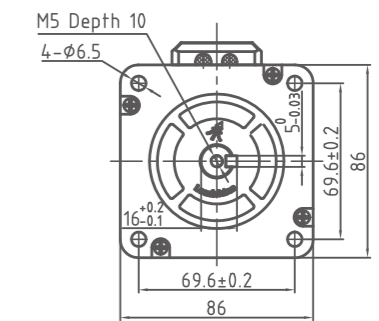

Unit: mm 1inch=25.4mm

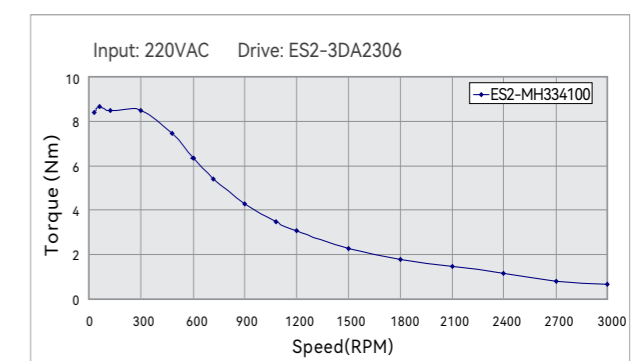
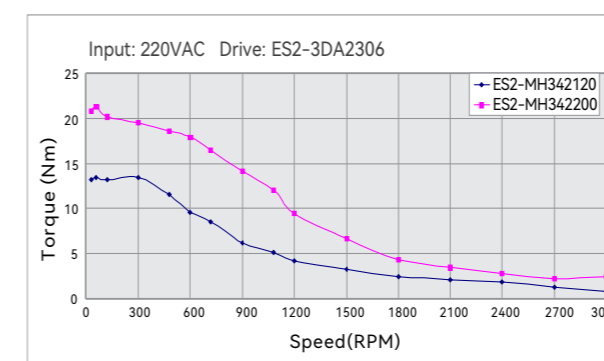
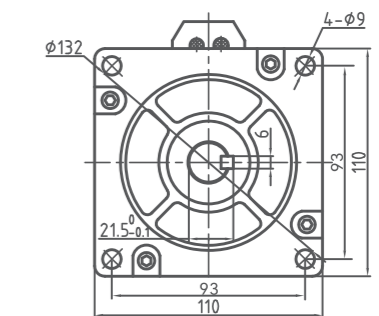



iEM & iCS Series

Integrated Stepper Motor

iEM series is integrated open-loop stepper motor with Leadshine's latest digital stepper technology.

iCS series is integrated closed-loop stepper motor with 14-bit single-turn absolute encoder for smooth and jitter-free motor start-up.

iEM and iCS series motors output torque can up to 3.5Nm and supports Modbus RS485 communication with Indexer control function. And with a more compact design, it is especially suitable for applications with strict mounting space requirements, and it is easy to use, which can further reduce customers' procurement and labor costs.

Extra-low Motor Noise

+

Lower Labor Cost

+

Lower Cable Cost

+

Save Mounting Space

Specifications

Encoder Type	Single-turn absolute magnetic encoder		
Encoder Resolution	14-bit		
Angle Calibration	Be sure to calibrate after encoder installation		
Step Angle	1.8°		
Position Accuracy	±0.09°		
Max Temperature	95° C		
Operation Environment	Temperature: -10° C ~ 50° C; Humidity: 85%RH Max		
IP Rate	IP20		
Radial Load (N) (Distance to the flange 10mm)	NEMA17	NEMA23	NEMA24
	30	75	90
Axial Load (N)	Less than motor weight		

iEM & iCS Interface



DIP Switches
Tuning Port

Signal I/O Interface
Power Input Interface
Indicator

Port	Description
DIP Switches	SW1-SW4: Microstep SW5: Motor Direction SW6: PUL&DIR and CW&CCW selection SW7: Smoothing filtering time SW8: Activated pulse edge for iEM series Open/closed loop control selection for iCS series
I/O Port	PUL+/-, DIR+/-, ENA+/-, ALM+/-

Dimensions

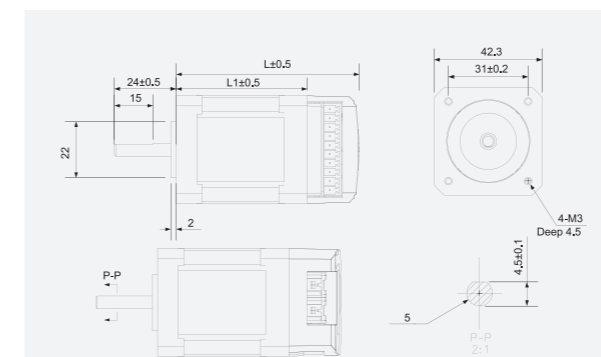

Model	L1 length	L length
iCS-1703	43	64
iCS-1706	51	72
iCS-1708	64	85

Unit: mm 1inch=25.4mm

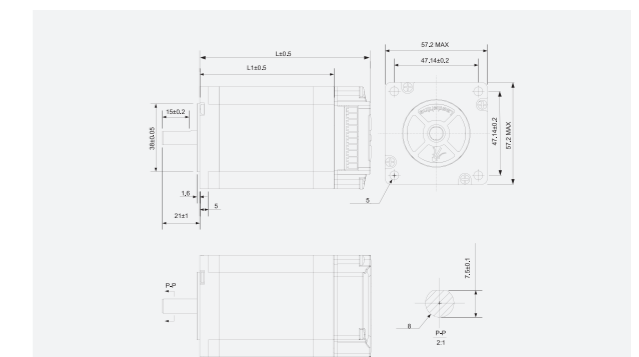

Model	L1 length	L length
iCS-2113	43	64
iCS-2323	51	72
iCS-2321-L	64	85
iCS-2331-L	88	109
iCS-2430	88	109
iCS-2435	101	122

iEM-RS & iCS-RS Interface

Power Input
Tuning Port
I/O Port
DIP Switches
RS485 Communication Port
LED Indicator

Port	Description
DIP Switches	SW1-SW5: Node ID SW6-SW7: Baud Rate SW8: 120Ω Terminal Resistance
I/O Port	7 digital inputs, 3 digital outputs

Dimensions

Unit: mm 1inch=25.4mm

Model	L1 length
iCS-RS1706	73mm
iCS-RS1708	86mm

Model	L1 length
iCS-RS2313	78mm
iCS-RS2323	99mm

Built-in uni-axial control instruction

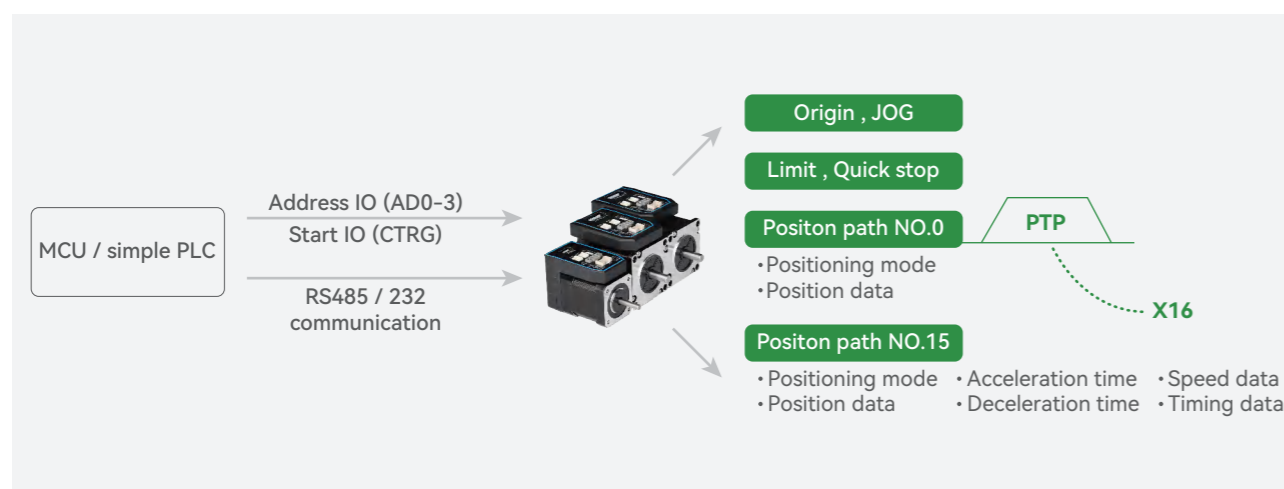

Specifications

Models	Type & Frame	Operating Voltage (VDC)	Control Mode	Holding Torque (N.m)	Logical Voltage (VDC)	Motor Length (mm)
iEM-1703	Open Loop NEMA17	20-36	Pulse&Dir	0.3	5	64
iEM-1706		20-36		0.6	5	72
iEM-1708		20-36		0.8	5	85
iEM-RS1706		20-36	RS485 Modbus	0.6	12-24	73
iEM-RS1708		20-36		0.8	12-24	86
iEM-2313	Open Loop NEMA23	20-50	Pulse&Dir CW&CCW	1.3	5	75
iEM-2323		20-50		2.3	5	96
iEM-2321-L		20-50		2.1	5	89
iEM-2331-L		20-50		3.1	5	109
iEM-RS2313		20-50	RS485 Modbus	1.3	12-24	78
iEM-RS2323		20-50		2.3	12-24	99
iEM-2430	Open Loop NEMA24	20-50	Pulse&Dir CW&CCW	3.0	5	109
iEM-2435		20-50		3.5	5	122
iCS-1703	Closed Loop NEMA17	20-36	Pulse&Dir	0.3	5	64
iCS-1706		20-36		0.6	5	72
iCS-1708		20-36		0.8	5	85
iCS-RS1706		20-36	RS485 Modbus	0.6	12-24	73
iCS-RS1708		20-36		0.8	12-24	86
iCS-2313	Closed Loop NEMA23	20-50	Pulse&Dir CW&CCW	1.3	5	75
iCS-2323		20-50		2.3	5	96
iCS-2321-L		20-50		2.1	5	89
iCS-2331-L		20-50		3.1	5	109
iCS-RS2313		20-50	RS485 Modbus	1.3	12-24	78
iCS-RS2323		20-50		2.3	12-24	99
iCS-2430	Closed Loop NEMA24	20-50	Pulse&Dir CW&CCW	3.0	5	109
iCS-2435		20-50		3.5	5	122

Power Supplies

- 260W: 24VDC output
- 360W: 24VDC/36VDC/48VDC output
- 400W: 60VDC output



LSP Series----Power Supplies

Overview

- 1.8 times overload
- Use Switch to select input voltage 220VAC ± 10% or 110 VAC ± 10%
- Big Power with High Efficiency
- Compact Size, Light in Weight
- Over-current, Over-voltage, Low-voltage Protections
- CE and RoHS

Specifications

Model	Output Voltage (VDC)	Continuous Current(A)	Peak Current(A)	Input Voltage	Power (W)	Dimensions (mm)	Weight (kg)
LSP-260-24	24	10.8	19.4	220VAC ± 10% or 110 VAC ± 10%	260	199*110*50	0.8
LSP-360-24	24	15	27		360	199*110*50	0.8
LSP-360-36	36	10	18		360	215*115*30	0.7
LSP-360-48	48	7.5	13.5		360	215*115*30	0.7
LSP-400-60	60	6.7	12		400	215*115*30	0.7

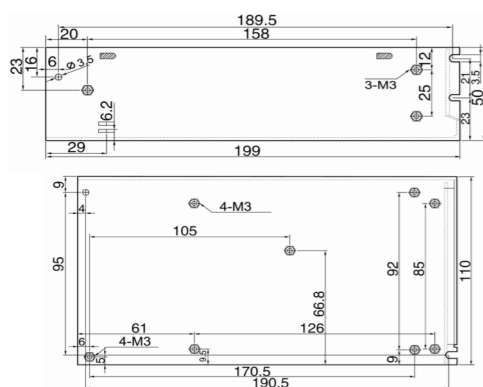

LSP-260-24, LSP-360-24

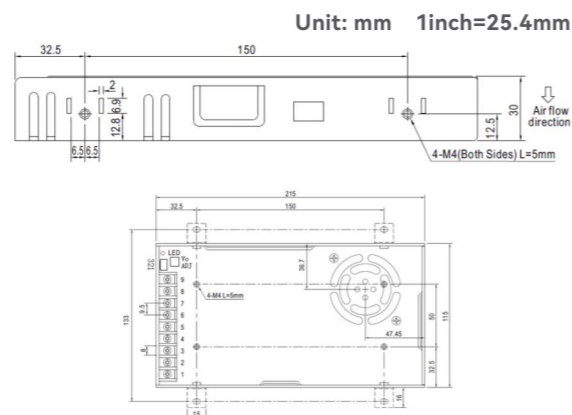

LSP-360-36, LSP-360-48, LSP-400-60

Gearboxes

- Straight tooth planetary Gearbox
- Matched 23, 24, 34 stepper motors
- Gear ratio 3:1, 5:1, 7:1, 10:1 are available

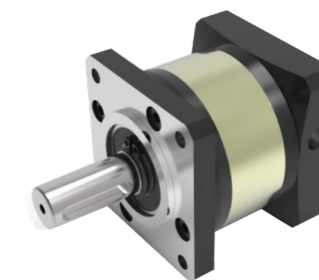

Size	60mm				90mm			
Gear Ratio	3	5	7	19	3	5	7	10
Rated Output Torque (Nm)	16.5	29.5	19.5	8.5	60	94	64	40
Max Output Torque(Nm)	33.0	59.0	39.0	17.0	120	188	128	80
Rotation Inertial(10-4kgm2)	0.107	0.092	0.091	0.091	0.4	0.291	0.285	0.283
Rated Input Rotation Speed (RPM)	4000				3500			
Maximum Input Rotation Speed (RPM)	8000				6000			
Maximum Radial Force (N)	485				1020			
Maximum Axial Force (N)	380				850			
Free-load torque (N.m)	0.6				0.8			
Full-load Efficiency	96%				96%			
Backlash (arcmin)	<12				<12			
Noise (dB)	≤58				≤62			
Weight (kg)	1.0				2.8			
Torsional Rigidity	2.3				7.5			
Average Life (h)	>20000							
Lubricant	Long-term Lubrication							
Rotation Direction	Input and output in the same direction							
Protection Class	IP65							
Installation Way	Arbitrariness							

Model	Gear Ratio	Matched Motors
PLF060-3-P2-BJ-6.35-38.1	3:1	NEMA 23 Stepper Motor with 6.35mm Shaft Diameter
PLF060-5-P2-BJ-6.35-38.1	5:1	
PLF060-7-P2-BJ-6.35-38.1	7:1	
PLF060-10-P2-BJ-6.35-38.1	10:1	
PLF060-3-P2-BJ-8-38.1	3:1	NEMA 23 Stepper Motor with 8mm Shaft Diameter
PLF060-5-P2-BJ-8-38.1	5:1	
PLF060-7-P2-BJ-8-38.1	7:1	
PLF060-10-P2-BJ-8-38.1	10:1	NEMA 34 Stepper Motor with 12.7mm Shaft Diameter
PLF090-3-P2-BJ-12.7-73	3:1	
PLF090-5-P2-BJ-12.7-73	5:1	
PLF090-7-P2-BJ-12.7-73	7:1	
PLF090-10-P2-BJ-12.7-73	10:1	NEMA 34 Stepper Motor with 14mm Shaft Diameter
PLF090-3-P2-BJ-14-73	3:1	
PLF090-5-P2-BJ-14-73	5:1	
PLF090-7-P2-BJ-14-73	7:1	
PLF090-10-P2-BJ-14-73	10:1	NEMA 34 Closed Loop Stepper Motor with 14mm Shaft Diameter
PLF090-3-P2-BJ-14-60	3:1	
PLF090-5-P2-BJ-14-60	5:1	
PLF090-7-P2-BJ-14-60	7:1	
PLF090-10-P2-BJ-14-60	10:1	



Headquarters China Leadshine Technology Co., Ltd.

+86 755 26411692 +86 755 26402718
www.leadshine.com
sales@leadshine.com (Sales)
tech@leadshine.com (Technical Support)
15-20/F, Block B, Nanshan i-Valley, Shuguang Community,
Xili Town, Nanshan District, Shenzhen 518055, China

North America Office Leadshine America, Inc.

1-949-608-7270 1-949-638-7298
www.leadshineusa.com
sales@leadshineusa.com (Sales)
support@leadshineusa.com (Technical Support)
26050 Towne Centre Dr. Foothill Ranch, CA 92610 USA



@Leadshine