

Working with Motion Studio 2

AC Servo Drive



TABLE OF CONTENTS

INTRODUCTION	4
GETTING STARTED WITH MOTION STUDIO 2	5
CONNECT TO SERVO DRIVE.....	7
FUNCTION NAVIGATION.....	9
SERVO DRIVE FUNCTIONS.....	9
<i>Parameters List</i>	<i>10</i>
<i>I/O settings.....</i>	<i>11</i>
<i>Scope.....</i>	<i>11</i>
<i>Position trial run.....</i>	<i>14</i>
<i>Velocity trial run.....</i>	<i>16</i>
<i>Pr-Motion</i>	<i>16</i>
<i>Trigger Pr-Motion using physical I/O</i>	<i>19</i>
<i>Zero Tracking Control.....</i>	<i>20</i>
<i>One-Click Tuning – Easy Tuning</i>	<i>22</i>
<i>One-click Tuning – Easy Tuning.....</i>	<i>28</i>
<i>Mechanical Properties Analysis</i>	<i>33</i>
<i>State Monitor.....</i>	<i>35</i>
<i>Error Alarm.....</i>	<i>36</i>
TOOL.....	37
<i>Inertia Ratio Identification</i>	<i>38</i>
<i>Control Command Settings</i>	<i>40</i>
<i>Holding Brake Settings.....</i>	<i>41</i>
<i>Electronic Gear Ratio</i>	<i>41</i>
<i>Gain adjustment</i>	<i>42</i>
<i>Position Loop.....</i>	<i>43</i>
<i>Velocity Loop.....</i>	<i>43</i>
<i>Current Loop (Torque Loop)</i>	<i>44</i>
<i>Motor Config. (Encoder Settings).....</i>	<i>44</i>
<i>Limit Settings</i>	<i>45</i>
<i>Alarm Limits</i>	<i>45</i>
<i>Black Box.....</i>	<i>46</i>
<i>Position Comparison</i>	<i>48</i>
ETHERCAT.....	51
<i>Object Dictionary</i>	<i>51</i>
<i>402 Observer.....</i>	<i>52</i>
<i>Diagnostics.....</i>	<i>53</i>
CONTACT US.....	54

Before we start

Please prepare the following items before we start to work with Motion Studio.

1. Leadshine AC Servo Drive (EL7/EL8 Series)
2. Leadshine AC Servo Motor (Recommended by Leadshine to be matched with driver)
3. Data cable
 - a. Mini-USB – For EL7 series AC servo drives
 - b. USB Type-C – For EL8 and EL7-RSP series AC servo drives.
(Please mind that a charging cable might not be able to transfer data.)
4. Motor power cables (**Direct** or **Aviation** connector depending on motor models)
5. Encoder cables(**Direct** or **Aviation** connector depending on motor models)
6. Motion Studio 2 can be downloaded on our website www.leadshine.com

System requirement to run Motion Studio 2

Operating system: Windows 7 or above

CPU: 1.5GHz or above

RAM: 512MB or above

Hard disk capacity: 10GB or above

Display: Resolution 1024*768, color 24 bit

Communication interface: USB Type-A series adapter

Introduction

Motion Studio is a free-to-use software developed by Leadshine Technology Co., Ltd. for simple commissioning of Leadshine AC servo products. Motion Studio 2 is a newly upgraded AC Servo Drives tuning software with redesigned modern looking GUI, many more features and highly user friendly with better configurable interface.

Through Motion Studio 2, users can connect the drivers to PC for parameters reading & writing, system performance tuning, trial run, driver status & data monitoring and much more. Most of the functions can be realized without connecting the driver to a main power supply.

There is no need to install Motion Studio 2. Download “Leadshine_Motion_Studio_EL8_EL7_Servo_V2.2.4 Beta” for designated Leadshine products on our website and unzip the file. Click on MotionStudio.exe to start the software. User manual for Motion Studio 2 can be found in Help folder. It is recommended to save Motion Studio 2 in other disks than C: drive.

<https://www.leadshine.com/download/Software.html>



Getting Started with Motion Studio 2

After unzipping “Leadshine_Motion_Studio_EL8_EL7_Servo_V2.2.4 Beta”, click on

 **MotionStudio.exe** to start Motion Studio 2.

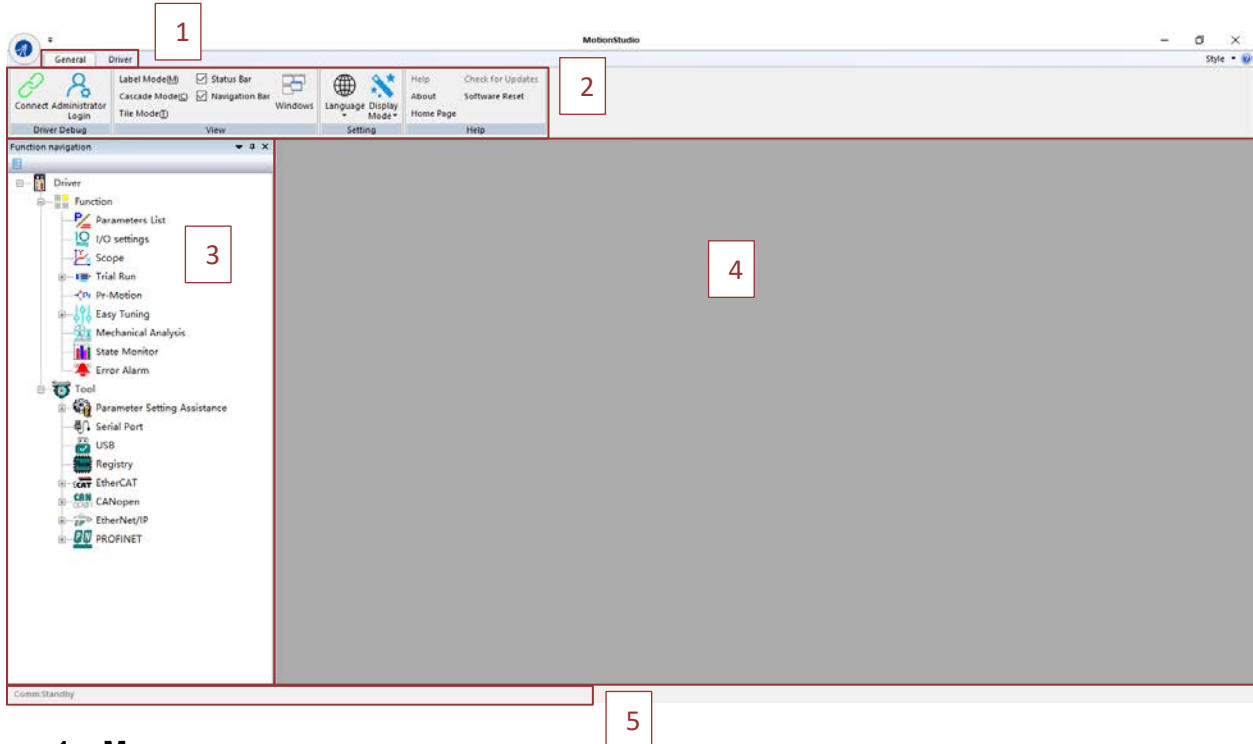

1. Menu

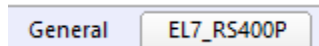

General	Driver connection interface, admin login and software related software such as view, languages, hard reset can be found on this tab
Driver(EL7-RS400P)	On the driver tab (display servo drive model when connected), quick access button, functions and tools can be found for more convenient application and settings.

2. General tab

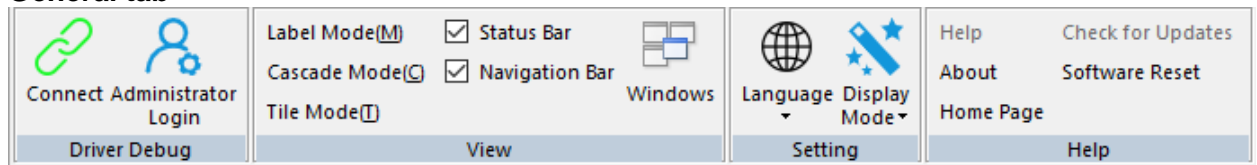

Driver Debug	Connect to driver and login as admin interfaces
View	Users can choose software layout mode as to fit respective working habits. Recommended to turn on both “Status” and “Navigation” bar.
Setting	Switch between English and Chinese. Display mode can also be modified in accordance to personal favor.
Help	Software version, Leadshine Homepage, Software hard reset can be found on this category

Driver tab

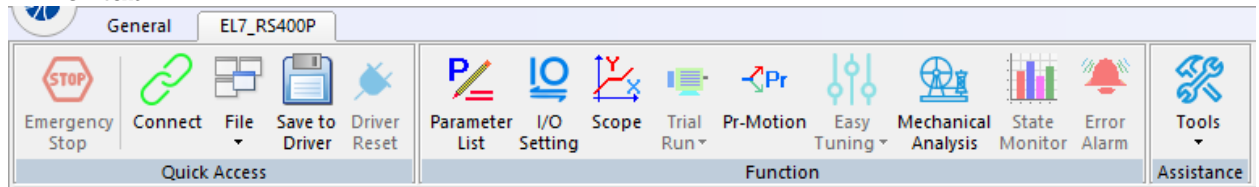

Quick Access	Emergency stop button, Drivers related operation: Connection settings, saving parameters to driver, reset driver and read saved files.
Function	Easy access to servo drive functions. Pr-Motion function is RS models specific and can't be access using other servo drive models.
Assistance	Servo drive set up interfaces can be accessed from "Tools". Newly added functions such as position comparison or black box are also available here. Most of these functions and settings can be accessed on the function navigation bar on the left panel as well.

3. Function Navigation

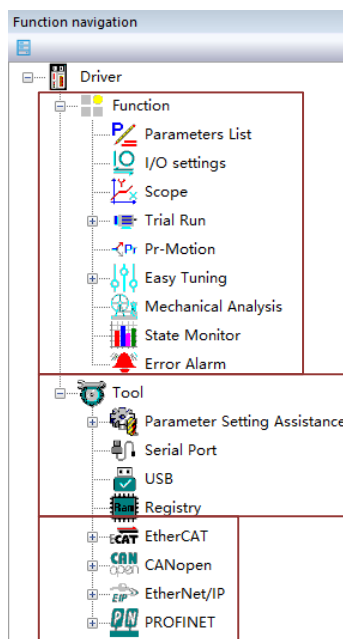

Function	Easy access to servo drive functions. Pr-Motion function is RS models specific and can't be access using other servo drive models. This are the same functions that can be found on the driver tab.
Tool	Most servo drive parameters settings interface and guidance can be found under this tab. Newly added functions such as position comparison and black box can be accessed under this tab as well. Serial Port, USB and Registry are rarely used and if any of them is needed, please contact Leadshine technical support.
Communication Protocol	Communication protocol related settings are model specific and can only be accessed with supported servo drives.

- 4. Operation interface
- 5. Status bar

Comm:Offline	Emergency Stop : NO	Servo:Disable	Alarm:No main power...
Comm	Show connection status of the servo drive		
Emergency stop	Show emergency stop status of the servo system		
Servo	Show servo drive status		
Alarm	Alarm message. To find out details and recommended solutions to alarms, please navigate to Error Alarm function on Function or on Navigation tree.		

Connect to Servo Drive



1. Click on **Connect**.
2. **“Connect”** pop-up window will appear.

Connect
✕

Online Mode
Offline Mode

Communication Mode RS232 ▾

Communication Port COM3 ▾ Refresh

Baud Rate 500000 ▾ Disconnect

Adaptive Baud rate



Series

Driver Model

Motor Model

Ports

Axis Count

Firmware

①	<ul style="list-style-type: none"> ▪ Online mode: Driver and motor connecting to USB port automatically identified ▪ Offline mode: Use offline mode to read parameters saved in PC.
②	<ul style="list-style-type: none"> ▪ Only RS232 communication mode is supported for the moment being. ▪ Communication Port can be automatically identified by clicking on “Refresh”. If driver failed to connect, please verify data cable or change to another USB port. ▪ Check “Adaptive Baud rate” and click on “Connect” to connect to servo products. <p><i>Driver can be connected to PC without main power supply.</i></p>
③	<ul style="list-style-type: none"> ▪ Servo products info such as series, model no., ports, axis count and firmware version can be found here.

3. When servo drive is connected to PC through data cable, **USb** will appear on the front panel of the servo drive. Err0D2 will appear due to no main power supply connected, it doesn't affect most tuning works of the servo drive.
 4. Once successfully connected, Comm on status bar will turn to “Comm: Online”.

Comm:Online
5. Connect window will close automatically in 3s after successfully connected.
6. If connection failed, please verify:
 - a. Data cable. Charging cable might not be able to transfer data.
 - b. Change another USB port.
 - c. Any alarm error which needs to be reset.

Function Navigation

Servo Drive Functions

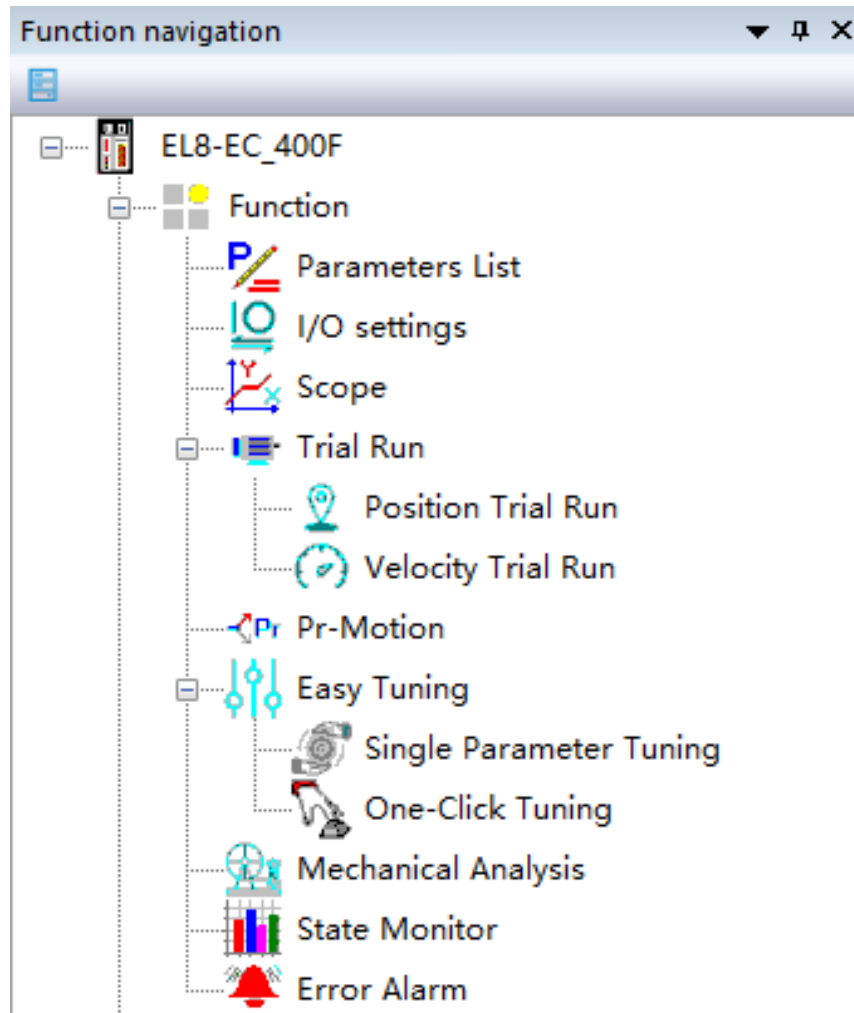

On the right panel, users can start any required servo drive functions from the function navigation list. If this list cannot be found, please tick "Navigation Bar" under General tab. Please keep in mind that some of the functions are AC servo drive series specific. For example, Pr-Motion can only be used when connect to RS series AC servo drives.

Parameters List

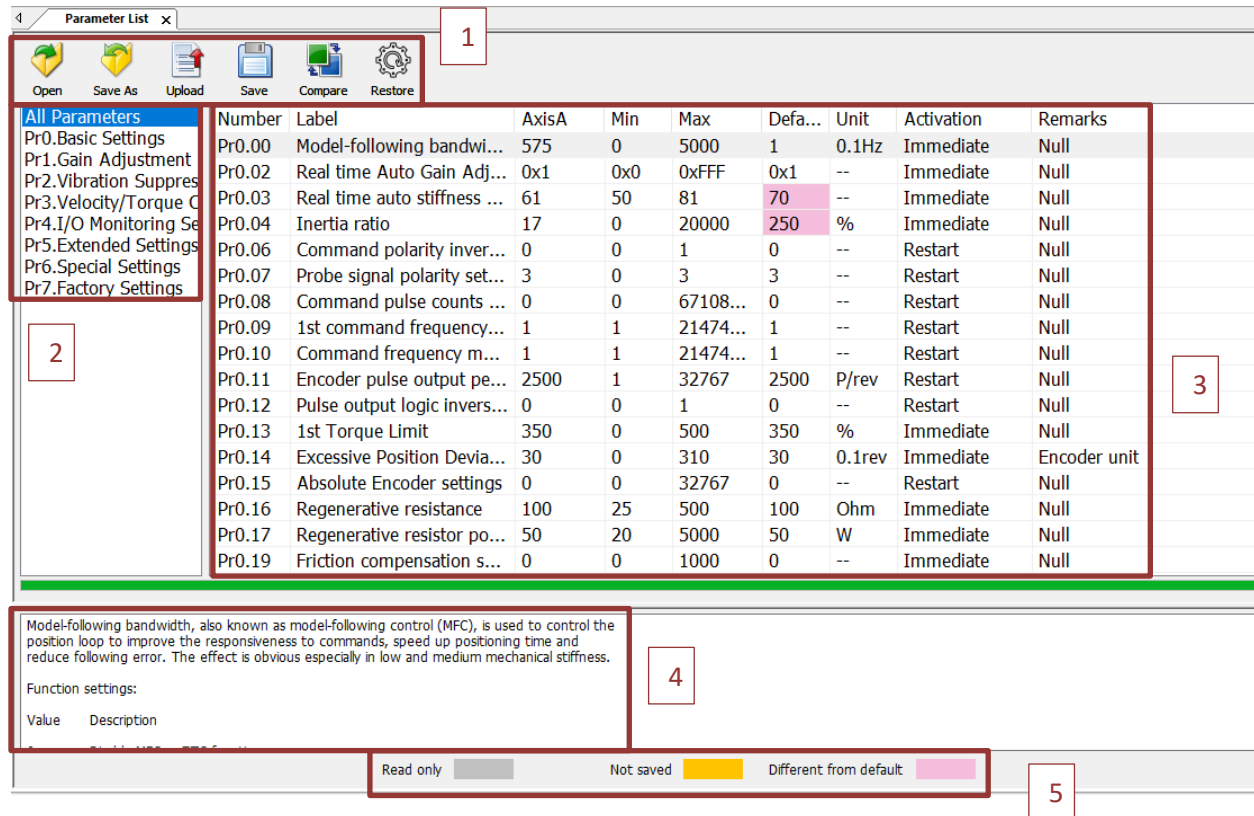

Number	Label	AxisA	Min	Max	Defa...	Unit	Activation	Remarks
Pr0.00	Model-following bandwi...	575	0	5000	1	0.1Hz	Immediate	Null
Pr0.02	Real time Auto Gain Adj...	0x1	0x0	0xFFFF	0x1	--	Immediate	Null
Pr0.03	Real time auto stiffness ...	61	50	81	70	--	Immediate	Null
Pr0.04	Inertia ratio	17	0	20000	250	%	Immediate	Null
Pr0.06	Command polarity inver...	0	0	1	0	--	Restart	Null
Pr0.07	Probe signal polarity set...	3	0	3	3	--	Restart	Null
Pr0.08	Command pulse counts ...	0	0	67108...	0	--	Restart	Null
Pr0.09	1st command frequency...	1	1	21474...	1	--	Restart	Null
Pr0.10	Command frequency m...	1	1	21474...	1	--	Restart	Null
Pr0.11	Encoder pulse output pe...	2500	1	32767	2500	P/rev	Restart	Null
Pr0.12	Pulse output logic inver...	0	0	1	0	--	Restart	Null
Pr0.13	1st Torque Limit	350	0	500	350	%	Immediate	Null
Pr0.14	Excessive Position Devia...	30	0	310	30	0.1rev	Immediate	Encoder unit
Pr0.15	Absolute Encoder settings	0	0	32767	0	--	Restart	Null
Pr0.16	Regenerative resistance	100	25	500	100	Ohm	Immediate	Null
Pr0.17	Regenerative resistor po...	50	20	5000	50	W	Immediate	Null
Pr0.19	Friction compensation s...	0	0	1000	0	--	Immediate	Null

Model-following bandwidth, also known as model-following control (MFC), is used to control the position loop to improve the responsiveness to commands, speed up positioning time and reduce following error. The effect is obvious especially in low and medium mechanical stiffness.

Function settings:

Value	Description

Read only Not saved Different from default

1	Function buttons	<ul style="list-style-type: none"> To open saved parameter files, save parameters as .lsr files for backup, upload parameters to drive and save parameters to drive. Parameters that are saved as .lsr or current parameter can be compared to default parameters. Use “Restore” button to reset driver/motor parameter back to factory default.
2	Parameter class	Different categories of parameters are listed on the left panel of the interface.
3	Parameters	Parameter value can be set on this list, please be aware that some modifications of parameters will only take effect after restart or axis halted. Please refer to Activation column for details.
4	Description	Descriptions for commonly use parameters are provided in this space down below. For further explanations on the parameters, please refer to respective AC servo drive series user manual which will be available on Leadshine homepage.
5	Status	Status indicator of parameters for the convenience of user when undertaking axis tuning.

I/O settings

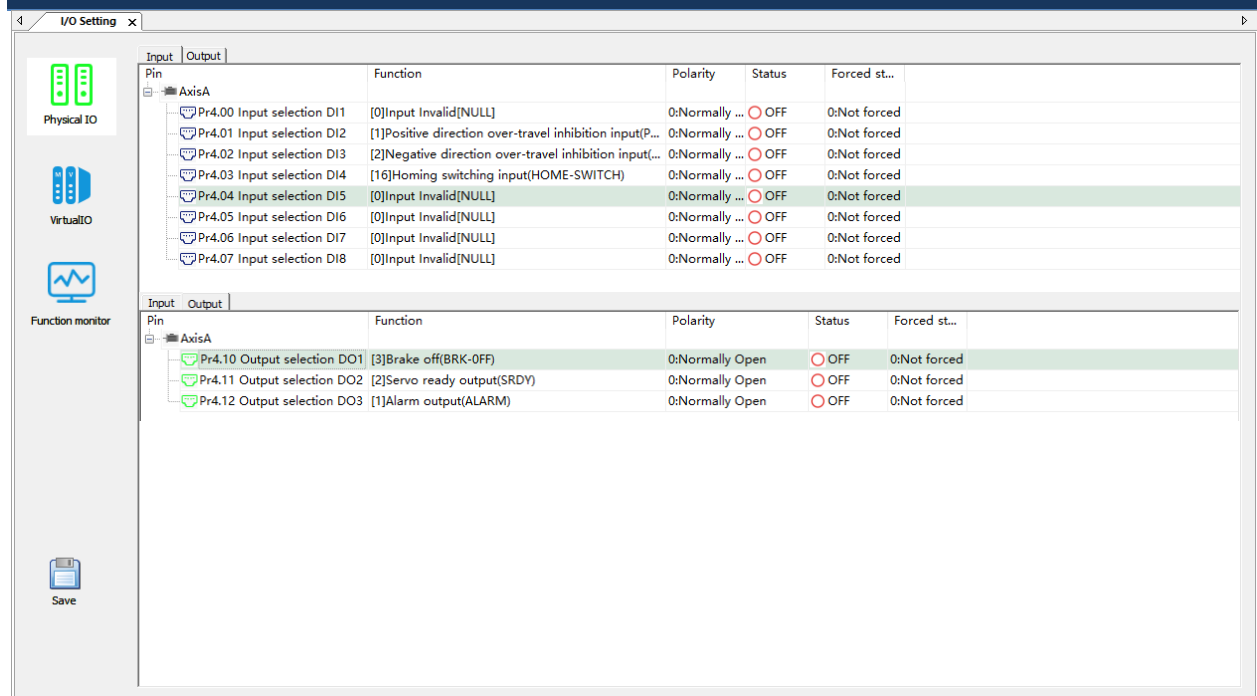

Pin	Function	Polarity	Status	Forced st...
Pr4.00 Input selection DI1	[0]Input Invalid[NULL]	0:Normally ...	<input type="radio"/> OFF	0:Not forced
Pr4.01 Input selection DI2	[1]Positive direction over-travel inhibition input(P...	0:Normally ...	<input type="radio"/> OFF	0:Not forced
Pr4.02 Input selection DI3	[2]Negative direction over-travel inhibition input(...	0:Normally ...	<input type="radio"/> OFF	0:Not forced
Pr4.03 Input selection DI4	[16]Homing switching input(HOME-SWITCH)	0:Normally ...	<input type="radio"/> OFF	0:Not forced
Pr4.04 Input selection DI5	[0]Input Invalid[NULL]	0:Normally ...	<input type="radio"/> OFF	0:Not forced
Pr4.05 Input selection DI6	[0]Input Invalid[NULL]	0:Normally ...	<input type="radio"/> OFF	0:Not forced
Pr4.06 Input selection DI7	[0]Input Invalid[NULL]	0:Normally ...	<input type="radio"/> OFF	0:Not forced
Pr4.07 Input selection DI8	[0]Input Invalid[NULL]	0:Normally ...	<input type="radio"/> OFF	0:Not forced

Pin	Function	Polarity	Status	Forced st...
Pr4.10 Output selection DO1	[3]Brake off(BRK-OFF)	0:Normally Open	<input type="radio"/> OFF	0:Not forced
Pr4.11 Output selection DO2	[2]Servo ready output(SRDY)	0:Normally Open	<input type="radio"/> OFF	0:Not forced
Pr4.12 Output selection DO3	[1]Alarm output(ALARM)	0:Normally Open	<input type="radio"/> OFF	0:Not forced

To assign required functions/signals to digital input, output of servo drive, polarity of DI/DO can be switched between Normally Open and Normally Close. Please make sure to check the wiring on the CN1 port of the servo drive as to match the assigned function/signal of the channel. Click on “Save” to save the modified settings to driver.

Scope

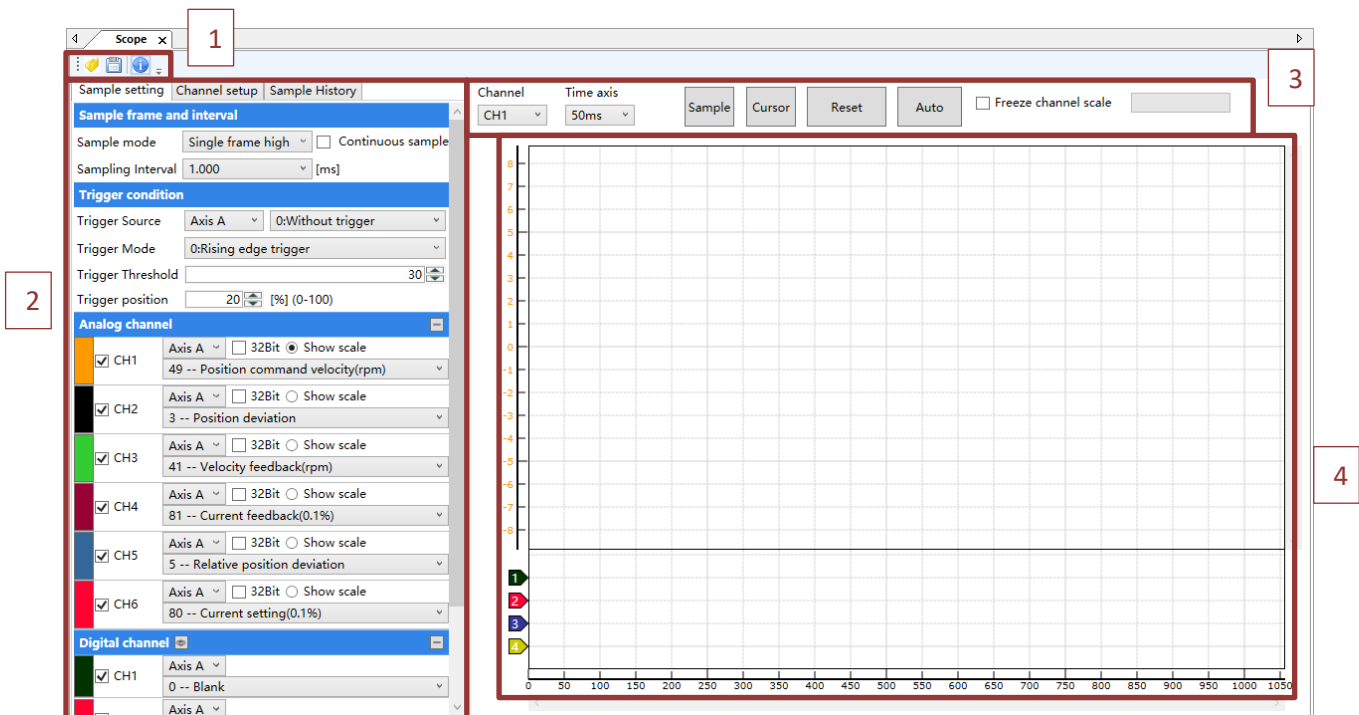

1. Function buttons

- To save waveforms recorded using Scope or to view previous saved waveforms.

2. Sampling settings

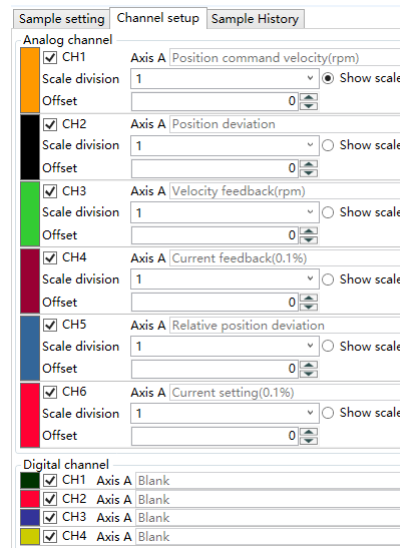
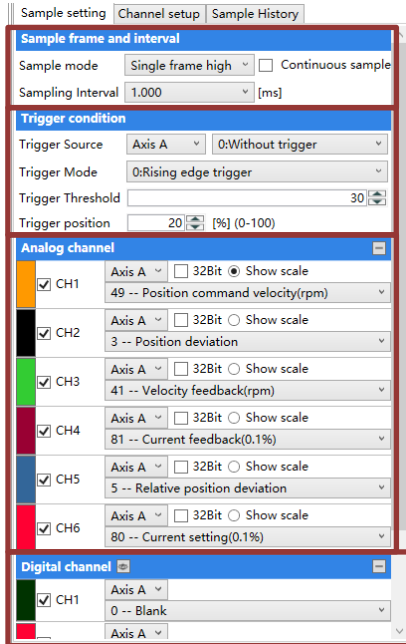

Scale division can be set and only scale of 1 chosen channel can be shown on the axis.
Use offset to set recorded waveform as accordance to view.

Sampling frame and interval	<p>Sample mode: Single frame high precision, Multi frame high precision, Multi frame low precision Sampling interval: Please keep in mind that sampling interval needs to be matched to motor velocity as to have a fully recorded data. Continuous sample: Data sampling goes on until this option is not ticked.</p>
Trigger Condition	<p>Trigger source: Set up trigger signal. Trigger mode: Trigger by signal rising or falling edge Trigger threshold: Sampling starts as condition value reaches set threshold value. Trigger position: Position from the whole motion where sampling begins</p>
Analog channel	<p>All 6 channels can be configured individually as per requirement. For more settings, please navigate to Channel Setup page. More variables have been added on Motion Studio 2 as to better monitor performance of the servo system and for easier analysis of servo error that might occur.</p>
Digital Channel	<p>To monitor the status of digital signal.</p>

3. Operation tab

Channel: CH1 | Time axis: 50ms | Sample | Cursor | Reset | Auto | Freeze channel scale

Oscilloscope Cursor

Cursor A

Horizontal axis cursor | t1 <> | t2 - t1: -585.000 ms |
 Vertical axis cursor | v1 <> | v2 <>

t2 <> | 1 / (t2 - t1): -1.709 Hz

Analog	Label	t1	t2	Max	Min	Mean	RMS	v1	v2
CH1	Position command velocity(rpm)	0	0	0.000	0.000	0.000	0.000	10.653	23.913
CH2	Position deviation	0	0	0.000	0.000	0.000	0.000	2.131	4.783
CH3	Velocity feedback(rpm)	0	0	0.000	0.000	0.000	0.000	2.131	4.783
CH4	Current feedback(0.1%)	-7610	-7610	-7610.000	-7610.000	-7610.000	7610.0	2296.7	5155.7
CH5	Relative position deviation	0	0	0.000	0.000	0.000	0.000	2.131	4.783
CH6	Current setting(0.1%)	0	0	0.000	0.000	0.000	0.000	2296.7	5155.7

Digital	Label	t1	t2
CH1	Blank	0	0
CH2	Blank	0	0
CH3	Blank	0	0
CH4	Blank	0	0

Channel	To show recorded waveform as to scale of selected channel
Time axis	To modify the scale of time axis
Sample	To start sampling
Cursor	By clicking on "Cursor", Oscilloscope Cursor interface will be opened and can be used to monitor the data of the recorded waveform. Data changes as according to the position of the cursor.
Reset	To reset Scope settings back to default. Default settings are good enough for most applications or can be used as reference for users that might not be familiar with Scope functions.
Auto	To automatically adapt recorded waveform to screen
Freeze channel scale	Freeze channel scale as not to accidentally change with scroll wheel on mouse
Progress bar	To show loading progress of recorded waveform.

- Waveform will be shown here with analog channel on the top and digital channel on the bottom. Digital channel can be hidden if not used.

Position trial run

Step 1: First, select the **motion mode** of trial run. It can be a to-and-fro (move in both directions) movement or a one-way motion in either negative or positive direction. Under **positioning mode**, you can pick either to teach the start and end point of the run or directly key in the required start/end position or distance. If start and end point are to be taught, please set lower velocity and acceleration if user is not familiar with particular models. Use “Forward” and “Reverse” button to move the motor and “Position 1 / 2” to set start and end point.

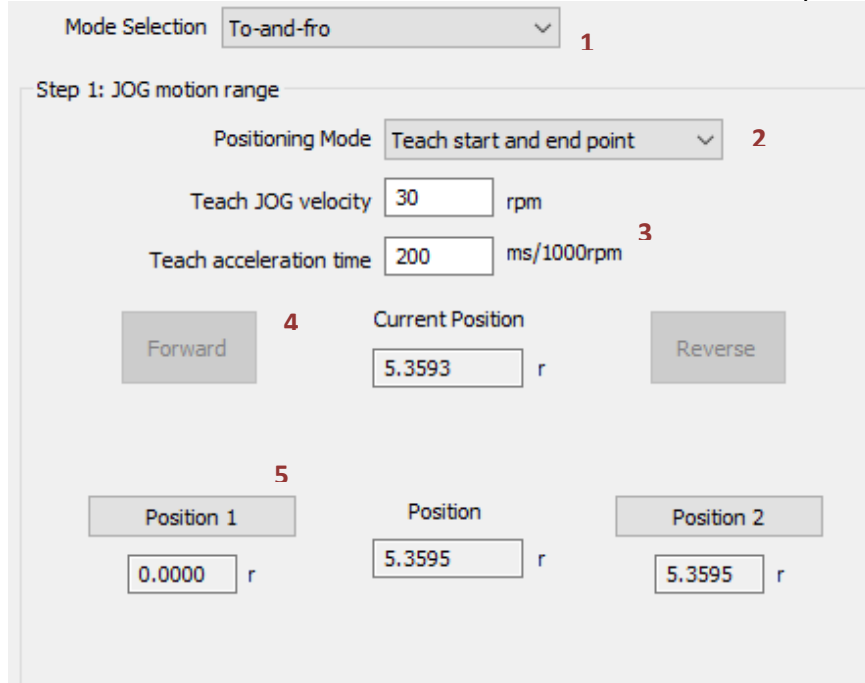

Step 2: Set JOG velocity, torque and acceleration (for actual trial run motion). No. of cycles would be how many times does the user want the complete trial run motion to perform and waiting time would be the interval time between each motion. Before performing trial run, please enable servo drive (Refer to the instructions below)

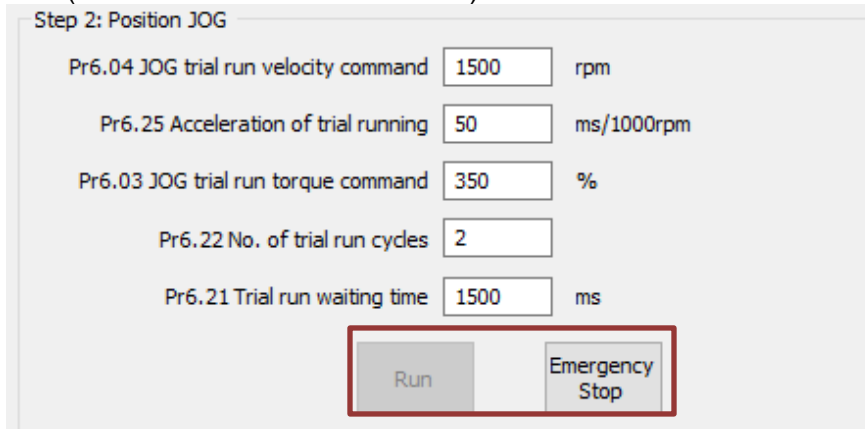

Use “**Run**” to start trial run after the above parameters are set correctly and servo drive is enabled. Please make sure the axis is within safe travel distance with no obstacles in the way.
Use “**Emergency Stop**” to stop axis in case of uncontrolled circumstances.

Step 3:

Enable servo drive by clicking on the button. Indicator on the right will turn to **ON** when servo drive is enabled.

Servo Enable **OFF**

External enabling disabled

Please tick on this option to make sure there won't be any other control signal interfering the trial run process.



Inertia ratio will be calculated automatically but would not be saved into driver's parameters. If inertia ratio needs to be set, please refer to Inertia Ratio Identification section for further explanations.

Calculated inertia ratio 16
Motor load rate 120
Motor speed 0

Motor load rate and speed are shown here for the convenience of monitoring.

Positive limit
Negative limit
Torque limit

Positive and negative limit of the axis can be monitored here. Torque limit is as set in parameter.

Scope function can be opened using this button.

Start Scope

Velocity trial run

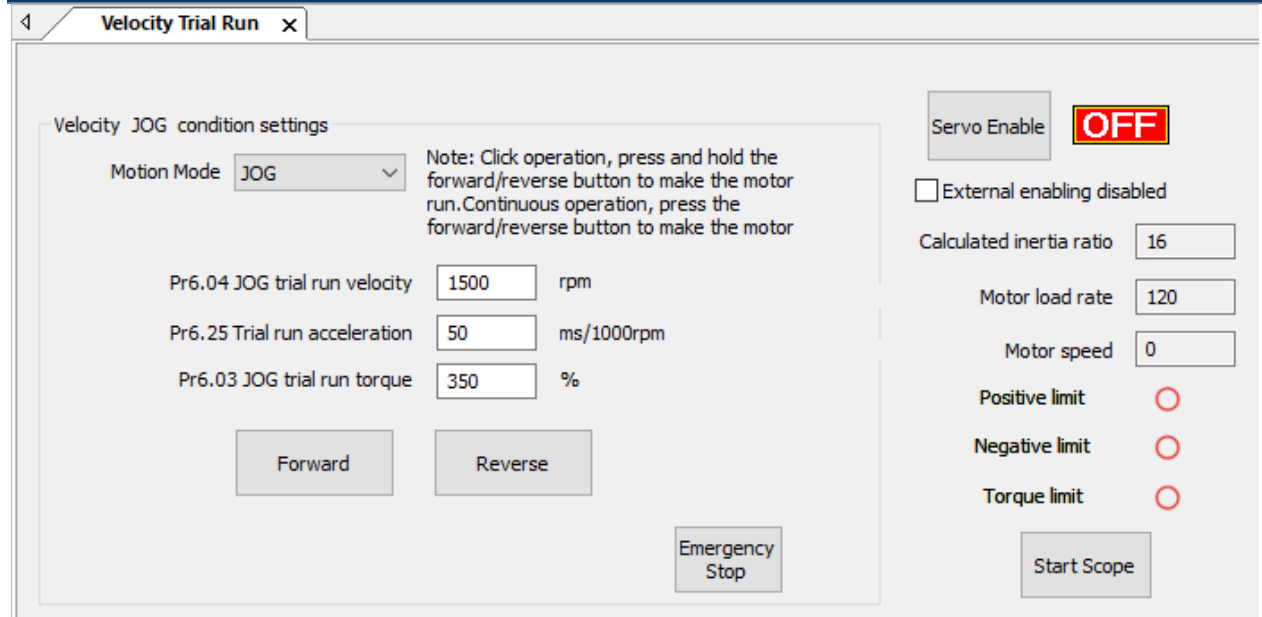

Motion mode	Choose between JOG or continuous motion
Parameters	Set up trial run velocity acceleration and torque. Please keep in mind to start from lower values with unfamiliar models.
Forward/Reverse	For JOG mode , press and hold either buttons to move the motor. In continuous mode , click on “Forward” to turn motor in positive direction and “Reverse” to turn motor in negative direction. Use “ Emergency Stop ” to stop axis in case of uncontrolled circumstances.

**Please refer to the section above for the operation involving the panel on the right.*

Pr-Motion

Using Pr-Motion function in Motion Studio 2, PR parameters in class 8 can be set including trigger settings, software position limit, JOG, homing, emergency stop, etc. Manual triggering of homing, path motion or emergency stop can also be triggered on this interface.

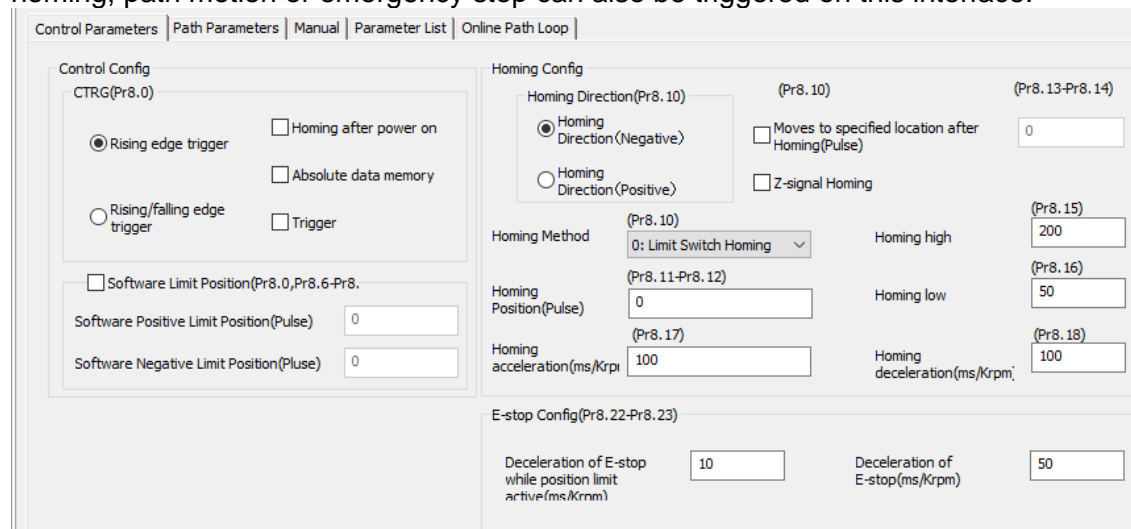

Most of PR control related parameters can be set on this page.

Motion Studio 2 User Manual

Path...	Positioning Mode	Positi...	Velocity(...	Acceleratio...	Deceleratio...	Pause Ti...	S-C...
0	0000H:._END	0	60	100	100	0	0x00
1	0000H:._END	0	60	100	100	0	0x00
2	0000H:._END	0	60	100	100	0	0x00
3	0000H:._END	0	60	100	100	0	0x00
4	0000H:._END	0	60	100	100	0	0x00
5	0000H:._END	0	60	100	100	0	0x00
6	0000H:._END	0	60	100	100	0	0x00
7	0000H:._END	0	60	100	100	0	0x00
8	0000H:._END	0	60	100	100	0	0x00
9	0000H:._END	0	60	100	100	0	0x00
10	0000H:._END	0	60	100	100	0	0x00
11	0000H:._END	0	60	100	100	0	0x00
12	0000H:._END	0	60	100	100	0	0x00
13	0000H:._END	0	60	100	100	0	0x00
14	0000H:._END	0	60	100	100	0	0x00
15	0000H:._END	0	60	100	100	0	0x00

Symbol description of positioning mode: Interrupt function (.: interrupt) (!: No Interrupt) + Position type (P: Position mode) (V: Velocity mode) (HOME: Homing mode) (CAP: Relative reference) + Absolute/relative (ABS: absolute command) (INC: Relative command) (REL: Relative to the motor) (CAP: Relative reference) + Jump Function (SJ: Positioning jump) (CJ: Continuous jump) (END: Stop)

Please refer to the explanation below to set up Positioning Mode column

All class 9 parameters for 0-15 paths can be found here once connected to a servo drive that supports PR mode.

Control Parameters | Path Parameters | Manual | Parameter List | Online Path Loop

Motion Operation

Pr9.02 Position(P) 'velocity(rpm) Pr9.03 Acceleration(ms/Krpm) Pr9.04 Deceleration(ms/Krpm) Pr9.05 Pause Time(ms) Pr9.06

Pr9.00 Positioning Mode

Homing

Pr8.46 Input: Command:

Pr8.47 Output: Motor Position(Pulse): Auto Refresh

Trigger Pr-Mode

Manual control of servo drive in PR mode can be done in this page.

Motion Operation	To set up parameters for Path 0. Click on "Start" and parameters will be automatically uploaded to driver. Use for simple tuning of PR motion involving only 1 path.
Homing	I/O and position display; Homing and emergency stop button. These homing settings differ from the settings on Control Parameters interface as these are only for manual homing.
Trigger Pr-Mode	To trigger operation of any of the 16 PR paths. Parameters for path 1 to 15 are set in Path Parameters interface.

Motion Studio 2 User Manual

Address	Number	Label	Value	Min	Max	Default	Unit	Remarks
40960	PAS.00	Pr control setting	0x0	0x0	0xFFFF	0x0	--	Set in the Control Parameter Window
40962	PAS.01	Pr motion path number	16	16	16	16	--	None
40964	PAS.02	Control register	0x0	0x0	0xFFFF	0x0	--	None
40974	PAS.07	Positive software limit L	0	-214...	21474...	0	pluse	None
40978	PAS.09	Negative software limit L	0	-214...	21474...	0	pluse	None
40980	PAS.10	Homing Method	0x0	0x0	0xFFFF	0x0	--	Set in the Control Parameter Window
40984	PAS.12	Homing position L	0	-214...	21474...	0	pluse	None
40988	PAS.14	Homing stop position L	0	-214...	21474...	0	pluse	None
40990	PAS.15	Homing high speed	200	1	6000	200	rpm	None
40992	PAS.16	Homing low speed	50	1	6000	50	rpm	None
40994	PAS.17	Homing acceleration	100	1	32767	100	ms/Krpm	None
40996	PAS.18	Homing deceleration	100	1	32767	100	ms/Krpm	None
40998	PAS.19	Holding time of homing...	100	0	65535	100	ms	None
41000	PAS.20	Torque value of homing...	100	0	65535	100	%	None
41002	PAS.21	Overpass distance settin...	0	0	65535	0	0.1r	None
41004	PAS.22	Deceleration of E-stop w...	10	1	32767	10	ms/Krpm	None
41006	PAS.23	Deceleration of E-stop	50	1	32767	50	ms/Krpm	None
41010	PAS.25	Absolute encoder positl...	0	-214...	21474...	0	--	None
41012	PAS.26	IO combined trigger mo...	0	0	65535	0	--	None
41014	PAS.27	IO combined filtering	5	0	65535	5	ms	None
41016	PAS.28	Output value of S code	0x0	0x0	0xFFFF	0x0	--	None
41018	PAS.29	PR alarm	0x0	0x8...	0x7FFF...	0x0	--	None

All PR mode and control exclusive parameters can be found on this list for convenience of tuning

**Most of the parameters can be found on the interfaces of this function and it would be easier to set up the parameters on respective interfaces.*

***Please refer to the model specific user manual for how-to on setting up the parameters*

Control Parameters | Path Parameters | Manual | Parameter List | Online Path Loop

Loop triggering

Pr8.43

Command position (P) Current path Outer loop count Run Emergency stop

Pr8.45

Motor position (P) Current loop count Suspend

Path	Path loop count	Interval(ms)	Jump interval(ms)
0	1	100	100
1	1	100	100
Right click the list to add a ...			

To run PR mode in a loop

Trigger Pr-Motion using physical I/O

1. Set up servo drive parameter such as Pr0.01 = 6. Required PR I/Os are set in Pr4.00-Pr4.15
2. Set up PR control parameters such as trigger, homing, emergency stop, velocity, etc as shown below
3. Set PR path parameter such as motion type, S-code, etc as shown below. The interface is divided into 3 parts:

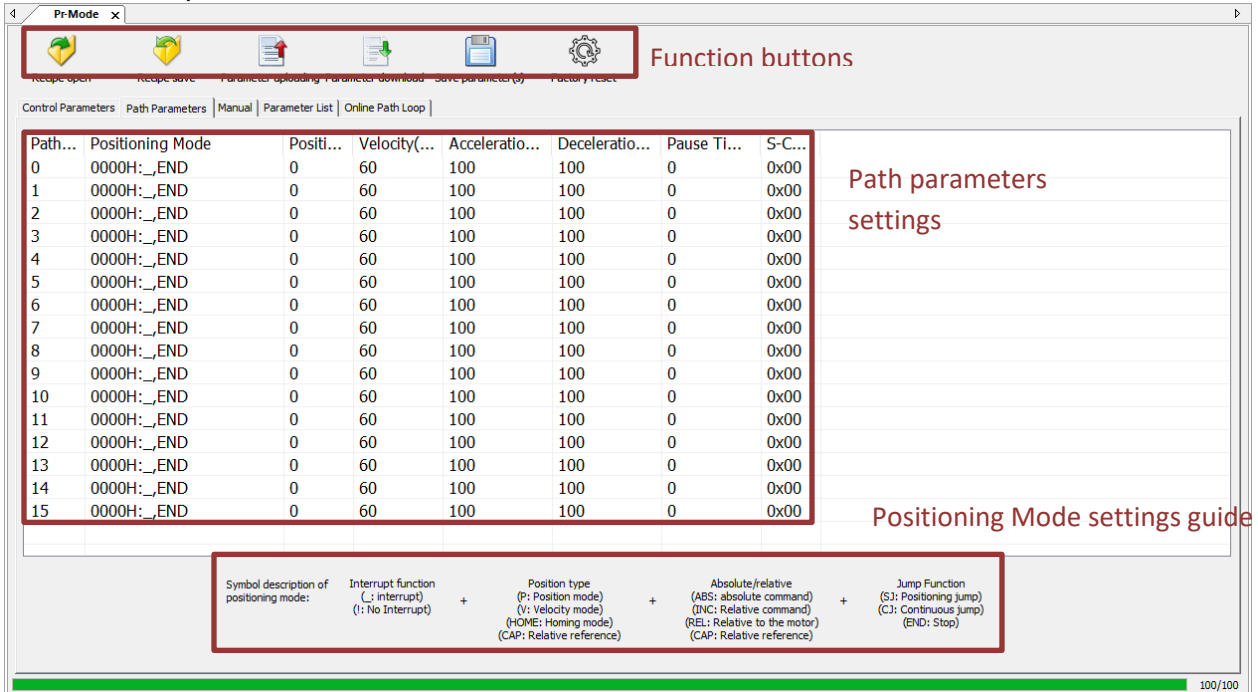

The screenshot shows the Pr-Mode interface with three main sections:

- Function buttons:** A toolbar at the top containing icons for Open, Save As, Upload, Download, Save, and Restore.
- Path parameters settings:** A table with columns for Path, Positioning Mode, Position, Velocity, Acceleration, Deceleration, Pause Time, and S-Code. The table lists 15 paths, all with Positioning Mode '0' and S-Code '0x00'.
- Positioning Mode settings guide:** A legend at the bottom explaining the symbols used in the Positioning Mode column, such as 'P' for Position mode and 'V' for Velocity mode.

Function buttons	Upload, download parameters to/from drives, save parameter, backup and reset to factory default.
Path parameters	Set PR path related parameters here. For more detailed explanations, please refer to servo drive model specific user manual.
Positioning mode settings guide	Short explanation on how to set up Positioning mode column

Remember to upload parameters to drive and save to drive after parameters setup.

4. Set up homing, trigger, I/O in PR mode as shown below:

****Please select required path when using edge trigger. Make sure the corresponding path is chosen in I/O path selection**

***Please set up I/O combination filter time when using I/O combination trigger. Make sure I/O signal filter time covers the change in signal level.**

Zero Tracking Control

Zero tracking control (ZTC) is able to realize a zero position deviation during acceleration/deceleration. This function increase multi axis precision and master-slave following.

- ZTC only available under position control mode.
- ZTC can only be enabled when Pr0.00 is valid.
- Model following control (MFC) and Zero Tracking Control (ZTC) cannot be used together at the same time.
- ZTC will be more effective after all the tuning work of the servo system has been done.

Parameter	Label	Description
Pr2.50	Model following control	0: Model following control - Default 1: Zero tracking control
Pr2.53	Dynamic friction compensation coefficient	Range: 0-1000, unit: 0.1% Unit: Changes in torque with the effect of friction on rotational speed. Only valid when MFC is activated
Pr0.00	Model following bandwidth	If Pr0.00 = 0, MFC and ZTC is deactivated. When Pr2.50 = 1 (Zero tracking control), higher bandwidth will improve following performance but noise will be higher.
Set the following parameters to default		
Pr2.51	Velocity feedforward compensation coefficient	Default value = 0 for zero tracking control.
Pr2.52	Torque feedforward compensation coefficient	
Pr2.54	Overtravel time constant	
Pr2.55	Overtravel suppression gain	

Before turning Zero Tracking Control ON

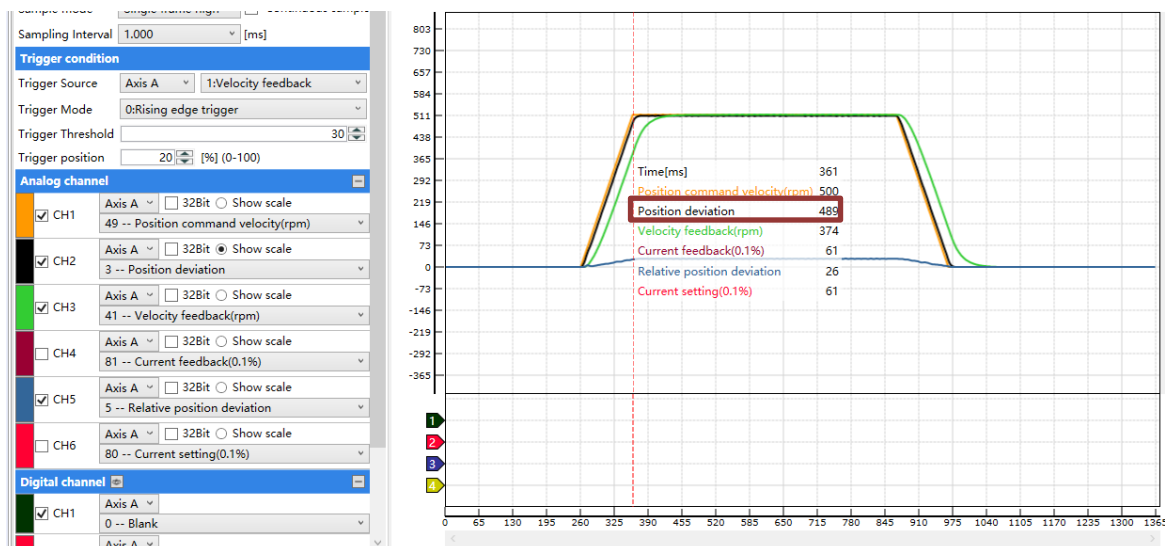

After turning Zero Tracking Control ON

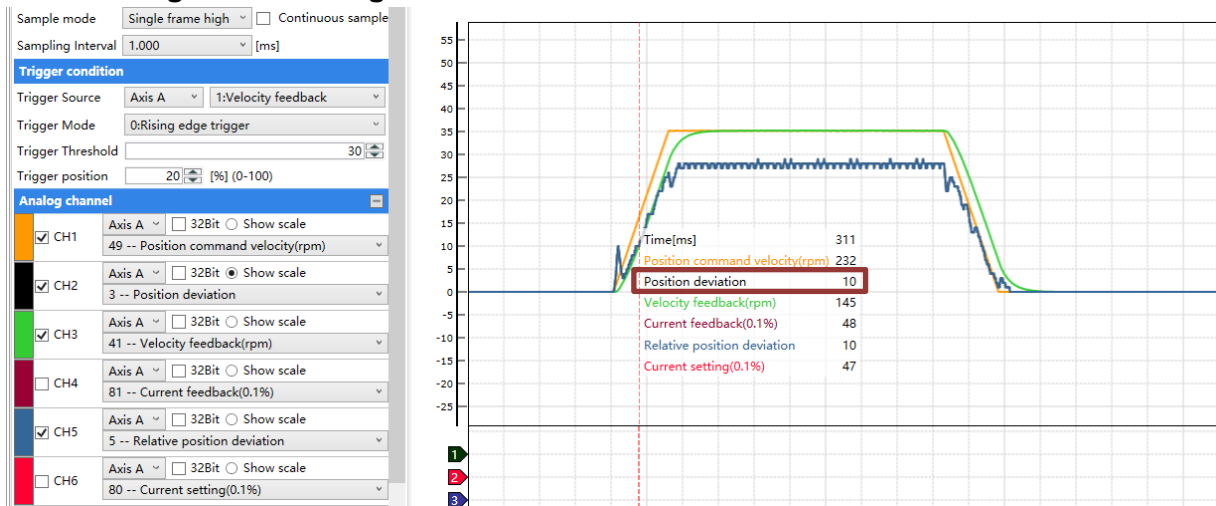

- Position deviation dropped drastically as a result of ZTC.

Step 1: Set Pr2.22 Position Command Smoothing Filter and Pr2.23 Position Command FIR Filter to 0. Set up vibration suppression and tune servo drive parameter to optimal values.

Step 2: Set Pr2.50 to 1 to activate Zero Tracking Control (ZTC)

Step 3: Refer to the explanation above to check the result of ZTC

Step 4: If position deviation is still relatively high at acceleration/deceleration phase, please tune Pr2.53 Dynamic friction compensation coefficient.

Dynamic friction coefficient

$$= \left| \frac{\text{Torque}(\text{Rotational speed 1}) - \text{Torque}(\text{Rotational speed 2})}{\text{Rotational speed 1} - \text{Rotational speed 2}} \right|$$

* *rated rotational speed*

(Rotational speed 1 and 2 is the speed at starting and end point of constant velocity phase after ZTC is activated. Torque can be checked on Motion Studio 2).

Step 5: If excessive position deviation still persists at the start-stop of acceleration/deceleration phase, increase Pr0.00 bandwidth and gain. It might reduce the position deviation but at the same time might cause some electrical noises.

One-Click Tuning – Easy Tuning

Set a mechanical stiffness level and the driver will automatically tune the parameters accordingly, including inertia measuring and vibration suppression to fulfill responsiveness and stability needs. At same time, more advanced functions can be applied, for example: Command pulse filter, low frequency vibration suppression, etc.

Recommended for applications where inertia changes is minute. Single parameter tuning is more complicated to set up compared to one-click tuning. Use single parameter tuning when one-click tuning doesn't fulfill the needs.

Easy Mode

1. Click on “Single Parameter Tuning” under Setup Wizard. Choose “Enable automatic inertia identification” and “Enable automation vibration identification”. If the system is heavily loaded with Pr0.03 mechanical stiffness value lower than 70, by selecting “Set low stiffness”, initial Pr0.03 value in Single Parameter Tuning will start at 70.

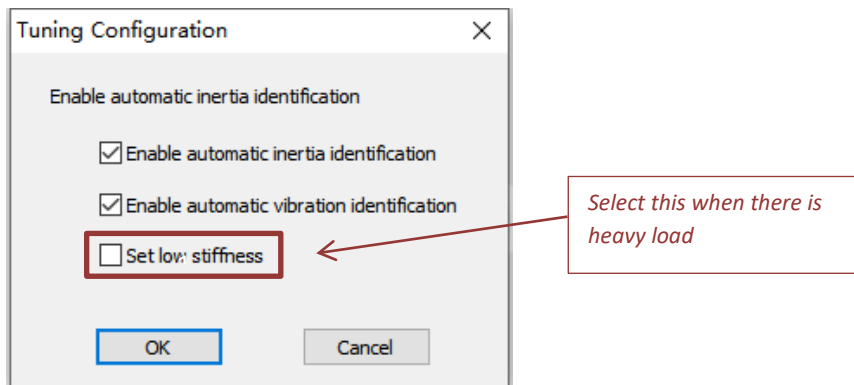

2. Set the value of MFC bandwidth, stiffness as per the table below under Easy Setup.

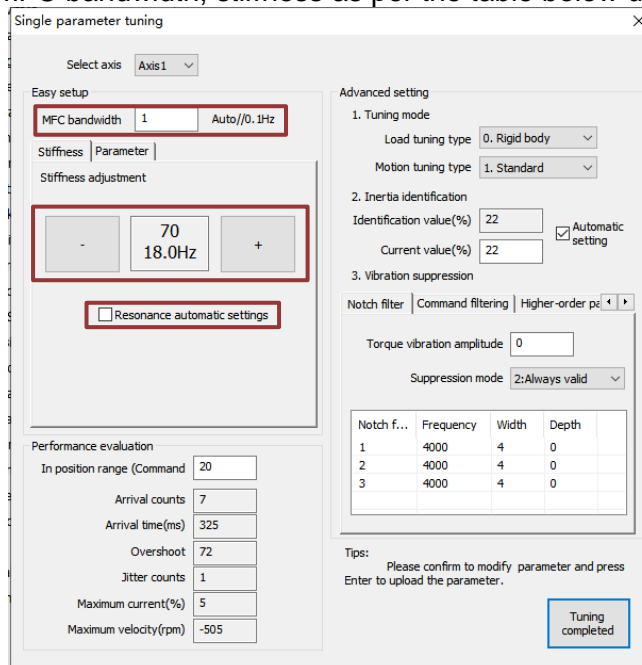

MFC bandwidth set value	Description
0	Deactivate model-following control function
【1】	Automatically adjust MFC bandwidth
2~9	Invalid
10~2000	Manually adjust MFC bandwidth; Recommended 30-100 for transportation belt applications

Stiffness level goes from 81-50 with 50 being highest stiffness level. Velocity response improves with higher stiffness level but vibration might occur. For flexible structures, decrease stiffness level and setup vibration suppression.

3. Resonance automatic settings: Automatically identified vibration under actual stiffness level settings. Default value is restored when no vibration is detected. If not selected, value will not be restored to default.

Advanced mode

4. Set Tuning mode.

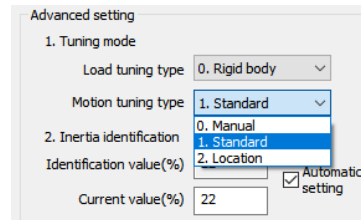
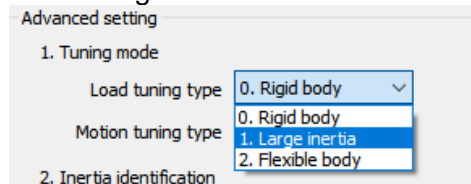

Load tuning type

Rigid body: Structure with low flexibility (i.e. screw leads)

High Inertia: 30-40 times higher than load inertia.

Flexible body: Low stiffness (i.e. belt)

Motion tuning type

Manual: Auto adjustment off. Parameters under Easy Setup available to be modified.

Standard: Prioritize stability. No switch gaining.

Location: Recommended for horizontal axis with variable load or ball screw structures.

5. Inertia identification is automatically enabled at the start.
 Identification value (%): Inertia ratio will be automatically identified with yellow box blinking on every successful identification
 Current value (%): If "Automatic setting" is selected, inertia ratio will be automatically synchronize to Pr0.04. If not selected, user can press Enter to set the value to Pr0.04.

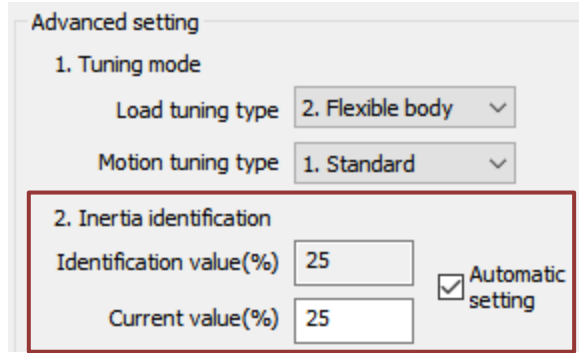

6. Vibration suppression: Notch filter
Torque vibration amplitude: 0% - Max. sensitivity, 100% - Deactivated (*Adjust accordingly*)
Suppression mode: 0 – Adaptive notch filter **deactivated**
 1 – Adaptive notch filter **valid for once**
 2 – Adaptive notch filter **always valid**
Notch filter: 1st, 2nd and 3rd notch filter
 Frequency(Hz): 50~2000
 Width: 0~20
 Depth: 0~99

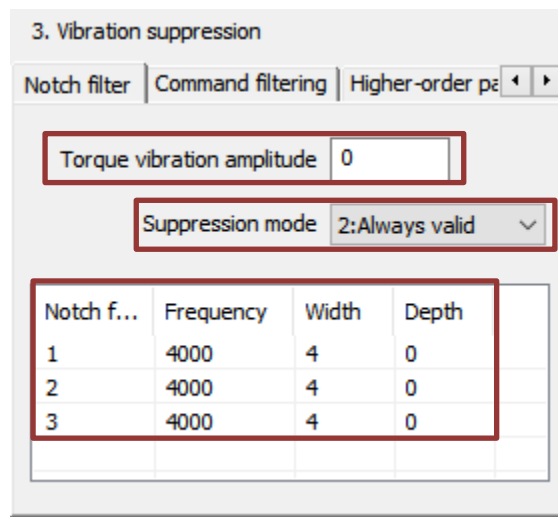

*Right click on notch filter parameters to **cut, paste or reset** the parameters*

Vibration suppression: Command filtering
 (These parameters are manually set, cannot be automatically identified.)

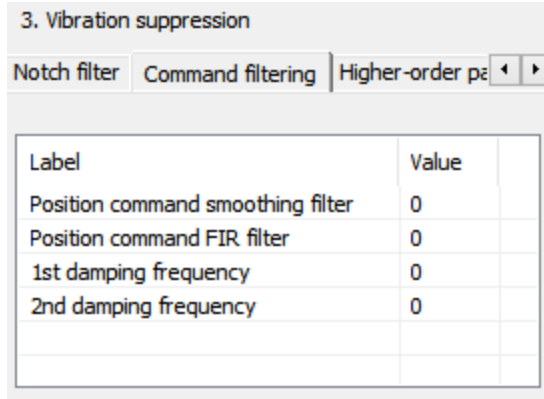

Parameter	Range(Unit)	Description
Position command smoothing filter	0~32767(0.1ms)	Large set value might elongate tuning time
Position command FIR filter	0~10000(0.1ms)	
1 st damping frequency	10~2000(0.1Hz)	To suppress mechanical end vibration
2 nd damping frequency	10~2000(0.1Hz)	

Vibration suppression: Higher-order Parameters

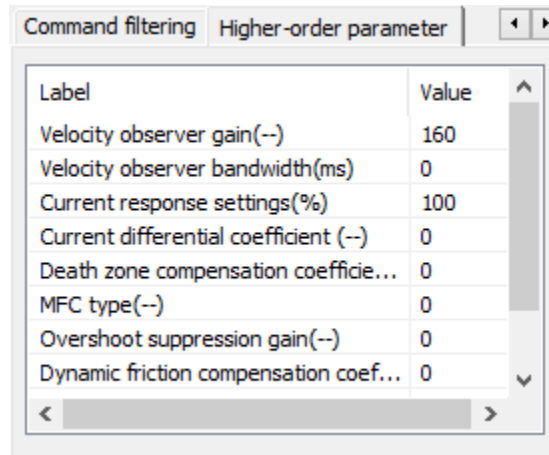

Parameter	Range(Unit)	Description
Velocity observer gain	0~32767	Defaulted to stable gain and bandwidth. Set = 1 to deactivate.
Velocity observer bandwidth	0~32767(ms)	
Current response settings	50~100(%)	Current loop related effective value ratio

7. After the settings are done, use trial run to run the motor for at least 5 cycles.

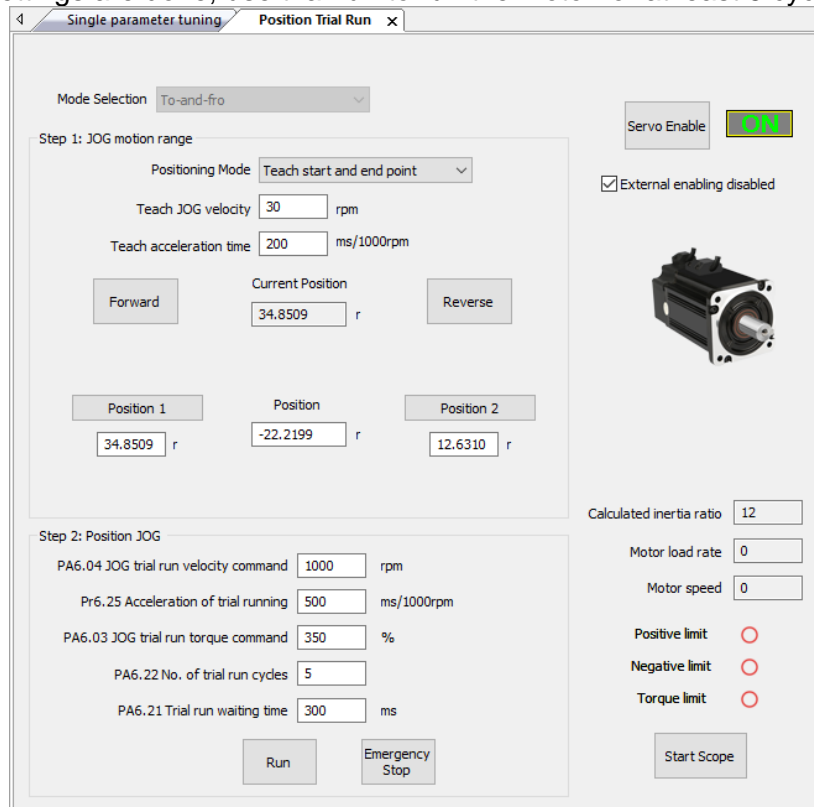

- Jog speed > 300rpm
- Acceleration < 600ms
- Position 1 and Position 2 should be around 5r
- Interval waiting time between cycles should be < 500ms with at least 5 cycles

8. Performance evaluation

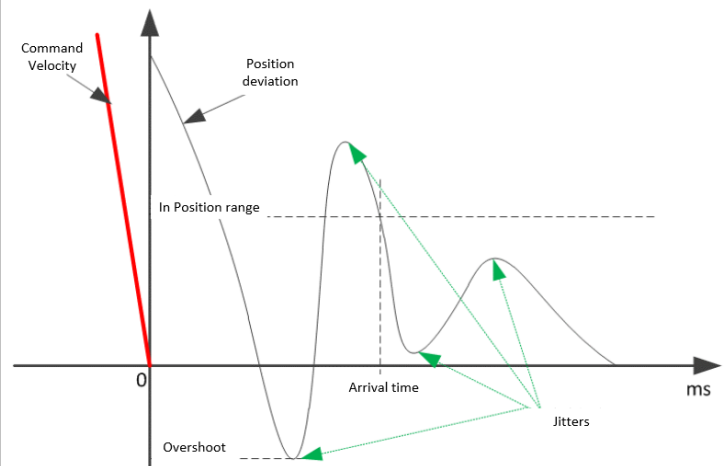
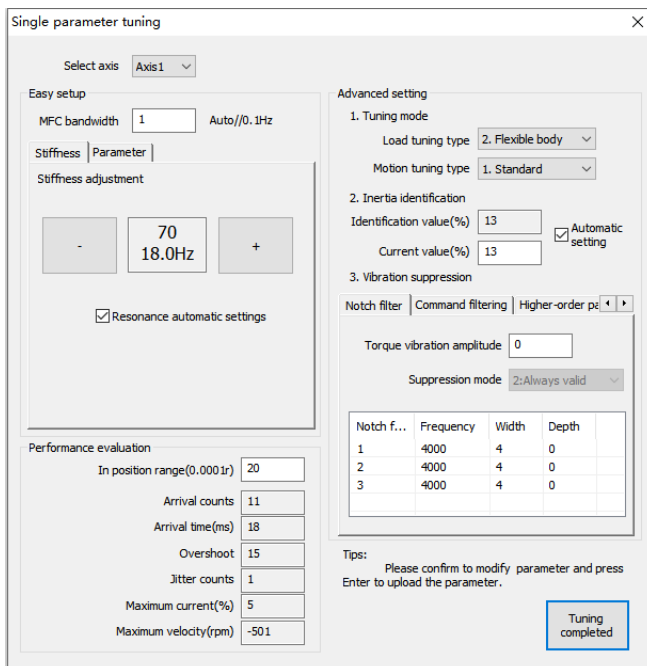

In position range	To set the velocity deviation between target velocity and actual velocity
Arrival counts	Number of times target value is arrived
Overshoot	The difference between target value and actual value. 10%(White) < Overshoot(Yellow) < 100% (Red)
Jitter counts	Detected jitters. Jitter count = 1(Yellow), more than 1(Red). Default(White)
Max. current	Percentage of max. current

Use Scope to get desired waveform by decreasing stiffness value manually.

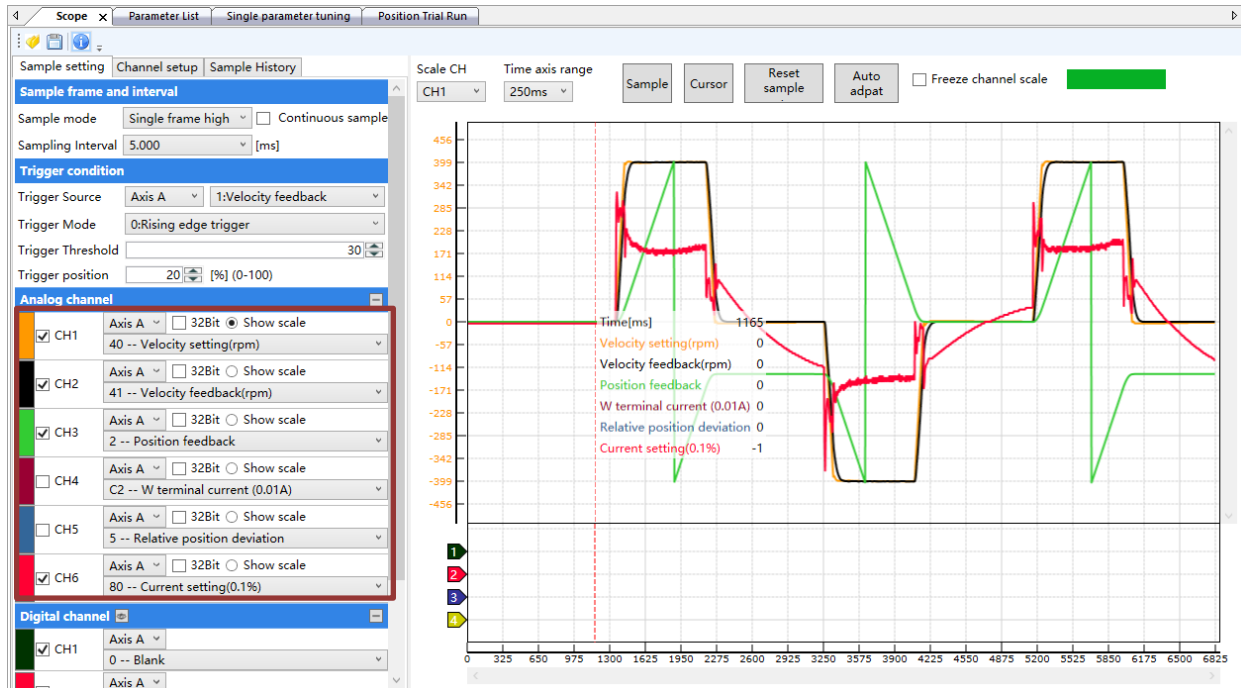

- Disable automatic inertia and vibration identification. Confirm to save parameters or restore to previous settings if the tuning setup is not wanted.

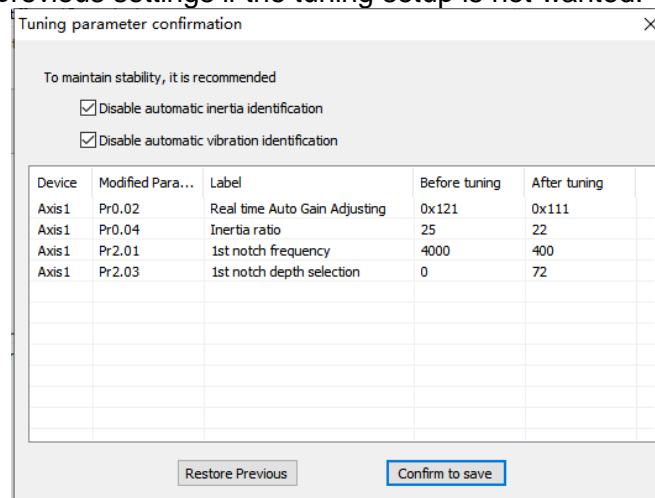

One-click Tuning – Easy Tuning

This function is able to automatically tune the most optimal gain parameters for the specific applications after the axis is in operation and learning. Corresponding paths and responsiveness level need to be set before using this function. Please refer to the flow chart below. Parameter will be saved to parameters file and can be used on similar axes.

Recommended for applications where inertia changes is minute.

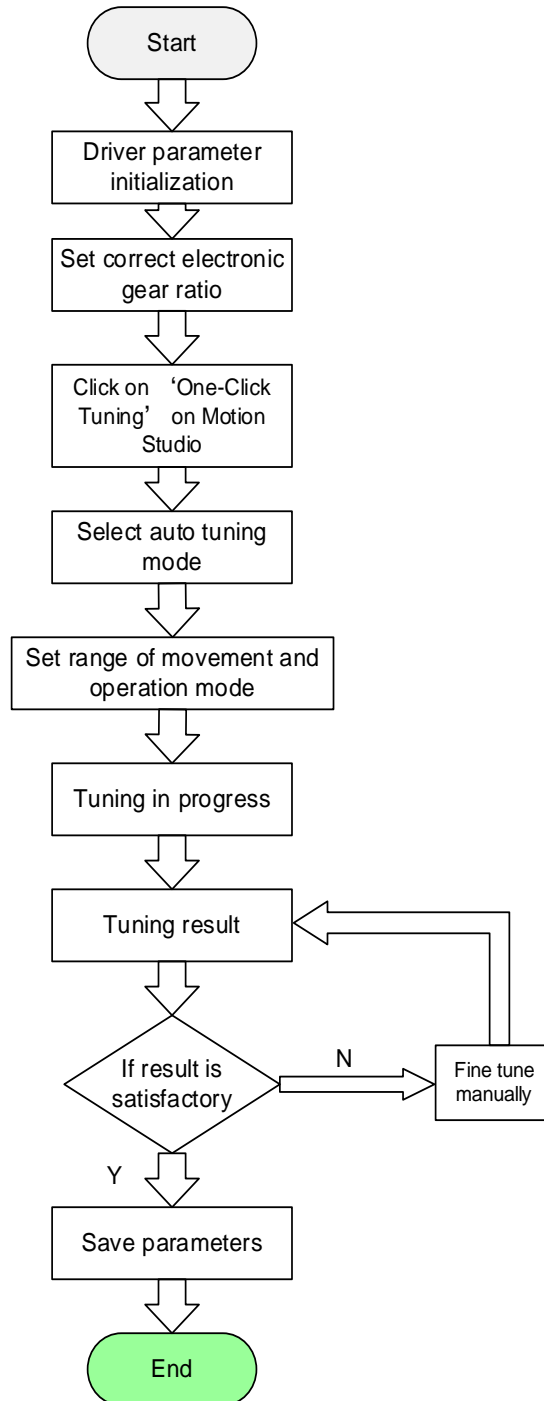

1. Restore parameters back to default to prevent the axis from going out of control during the tuning process.

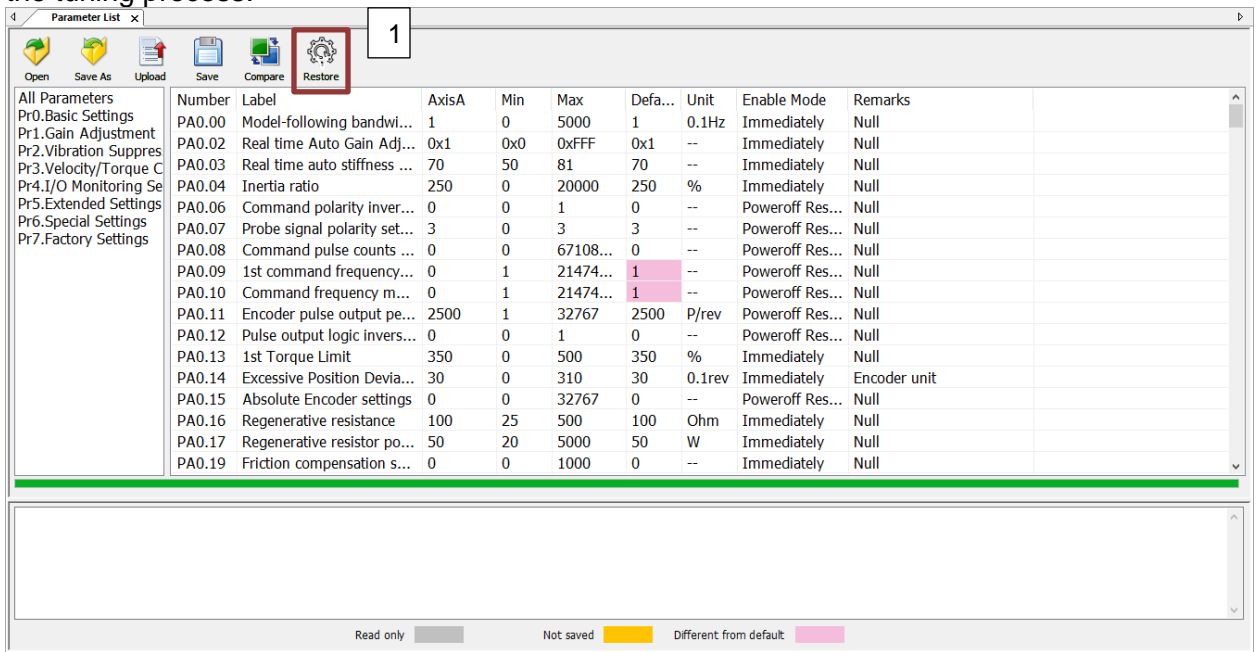

Number	Label	AxisA	Min	Max	Defa...	Unit	Enable Mode	Remarks
PA0.00	Model-following bandwi...	1	0	5000	1	0.1Hz	Immediately	Null
PA0.02	Real time Auto Gain Adj...	0x1	0x0	0xFF	0x1	--	Immediately	Null
PA0.03	Real time auto stiffness ...	70	50	81	70	--	Immediately	Null
PA0.04	Inertia ratio	250	0	20000	250	%	Immediately	Null
PA0.06	Command polarity inver...	0	0	1	0	--	Poweroff Res...	Null
PA0.07	Probe signal polarity set...	3	0	3	3	--	Poweroff Res...	Null
PA0.08	Command pulse counts ...	0	0	67108...	0	--	Poweroff Res...	Null
PA0.09	1st command frequency...	0	1	21474...	1	--	Poweroff Res...	Null
PA0.10	Command frequency m...	0	1	21474...	1	--	Poweroff Res...	Null
PA0.11	Encoder pulse output pe...	2500	1	32767	2500	P/rev	Poweroff Res...	Null
PA0.12	Pulse output logic invers...	0	0	1	0	--	Poweroff Res...	Null
PA0.13	1st Torque Limit	350	0	500	350	%	Immediately	Null
PA0.14	Excessive Position Devia...	30	0	310	30	0.1rev	Immediately	Encoder unit
PA0.15	Absolute Encoder settings	0	0	32767	0	--	Poweroff Res...	Null
PA0.16	Regenerative resistance	100	25	500	100	Ohm	Immediately	Null
PA0.17	Regenerative resistor po...	50	20	5000	50	W	Immediately	Null
PA0.19	Friction compensation s...	0	0	1000	0	--	Immediately	Null

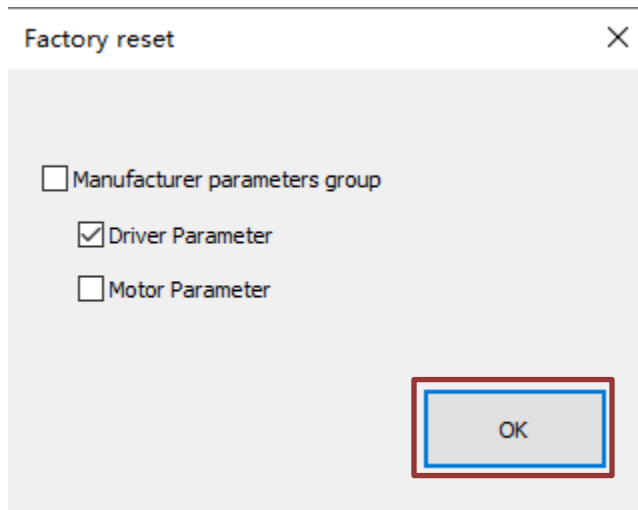

Factory reset

Manufacturer parameters group

Driver Parameter

Motor Parameter

OK

2. Click on “Self Adjusting” and choose “One-Click Tuning” from the drop down list. Set tuning response level accordance to mechanical stiffness of specific application, tuning mode, target in position range and its unit. Click “Next” to go on to next step.

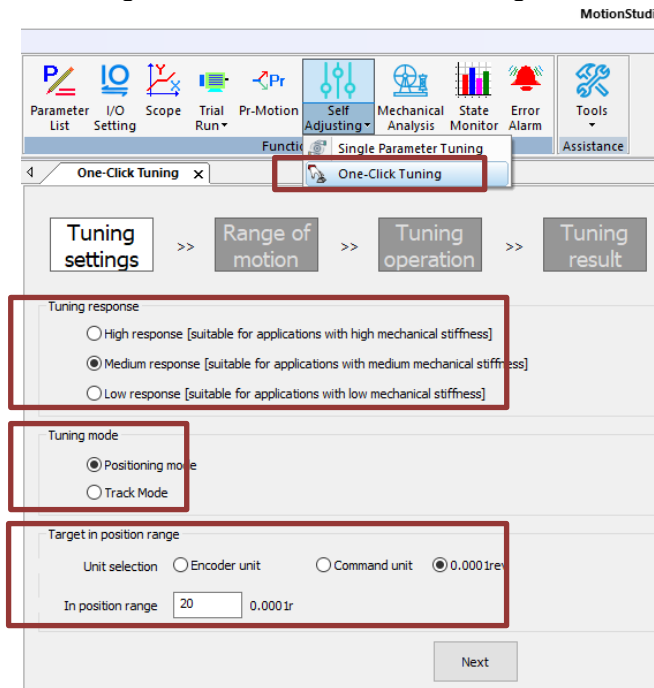

High response for structures with high mechanical stiffness such as ball screw. Medium response is more commonly used. Low response is usually for belt applications.

3. Set the velocity, acceleration and range of motion for the tuning process. Please make sure the difference between position 1 and 2 is more than 0.5r for more accurate inertia ratio identification. Recommended to set at around 5 revolutions. Click on “Next” to start tuning.

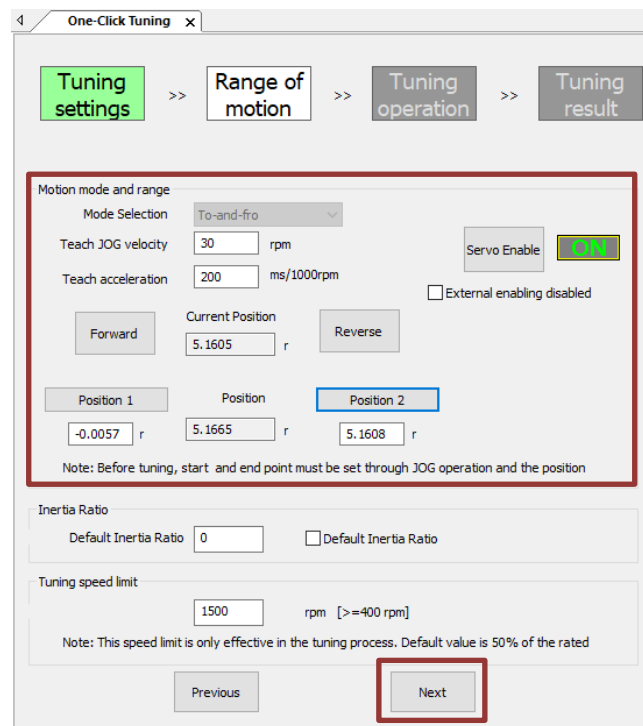

- Please secure the motor properly as it might undergo rather strong vibration during tuning. Inertia ratio will also be identified during the process. Please wait until progress bar reaching 100%. It might jump automatically to tuning results. If motor goes out of control during the process, please use “Emergency Stop” button to stop the process.

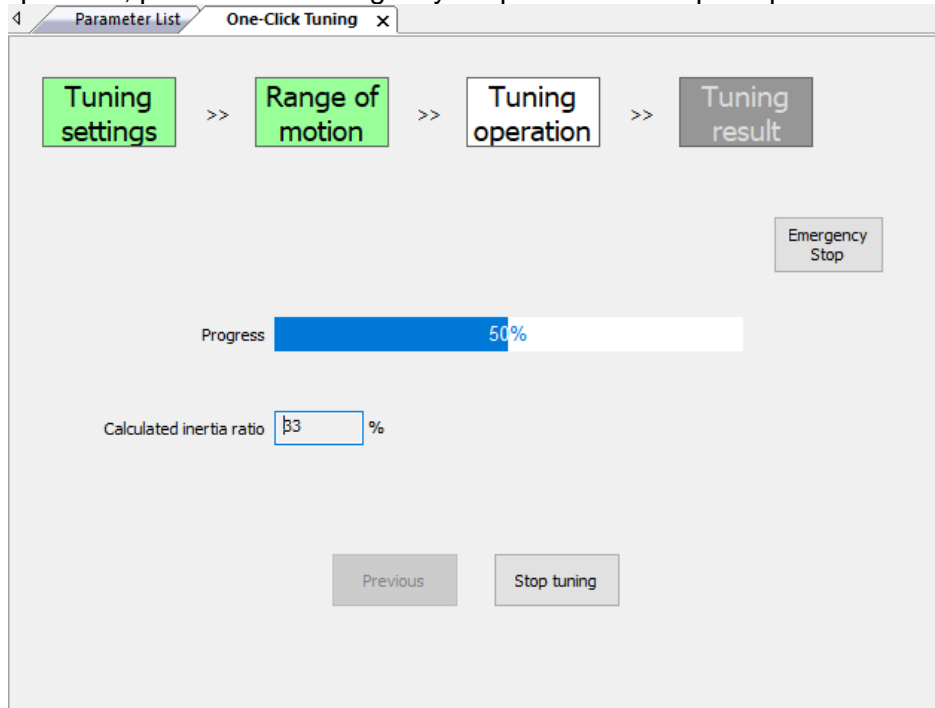

- After getting the result of the tuning, please click on “Manual fine adjustments” tab to do some fine adjustments if needed according to the waveforms on Scope.

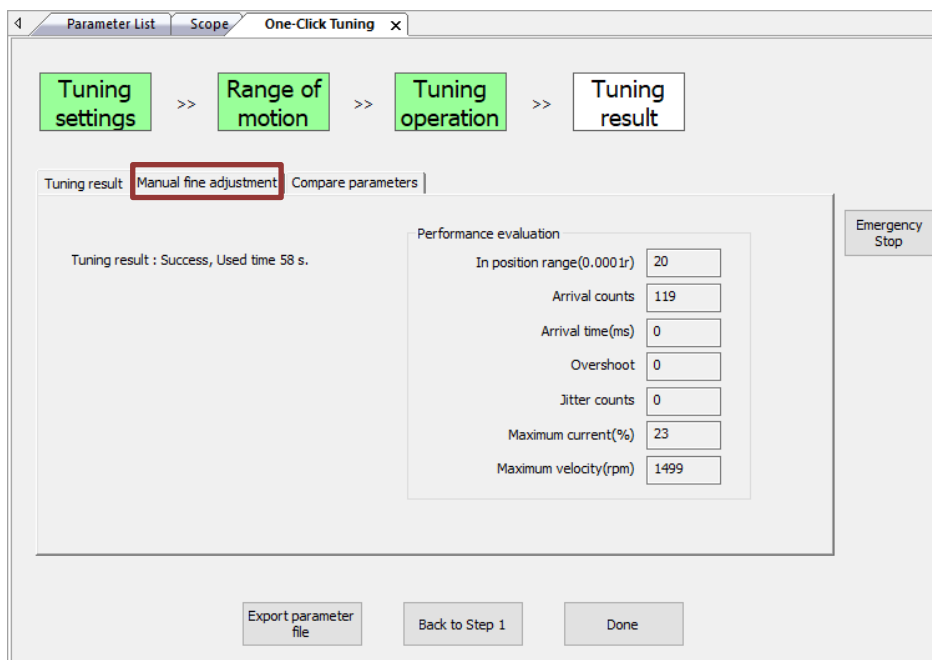

- After doing some fine adjustments to the parameters, start Scope to check if users have got the required results.

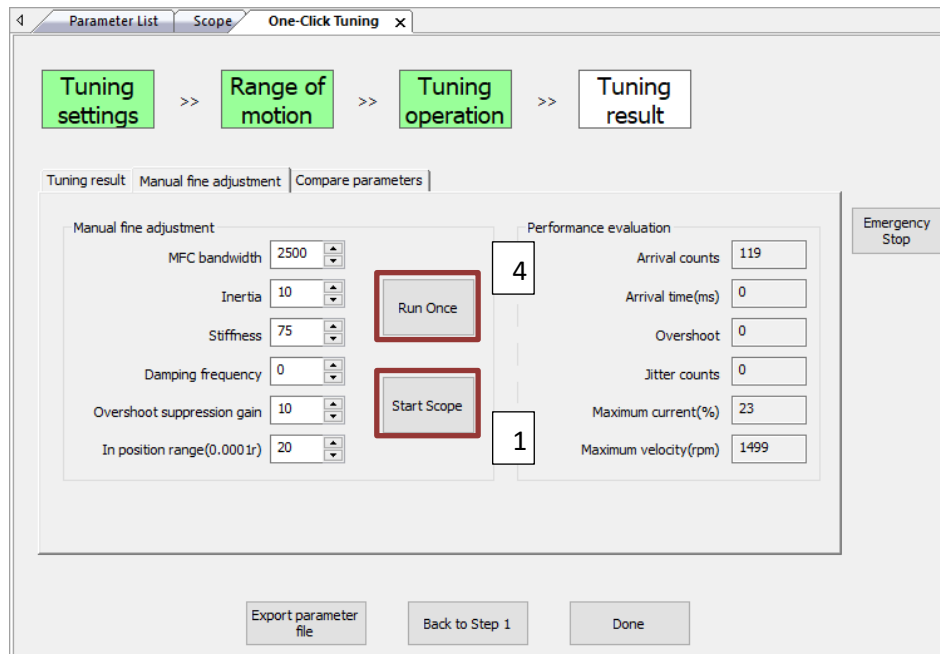

Click on “Reset” to set Scope to default and click on “Sample” to start monitoring servo system data. Then, click on “Run Once” to start monitoring. Waveform will be automatically updated.

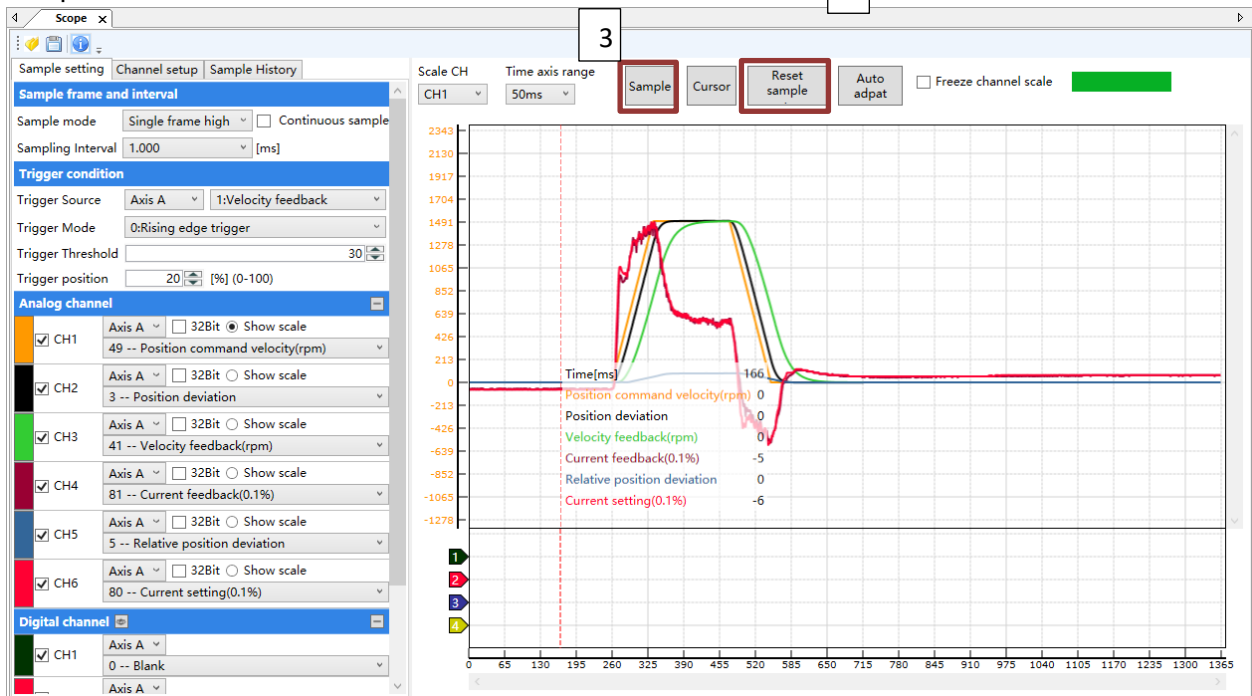

**Only click on “Reset” button once after first starting Scope tool.*

Mechanical Properties Analysis

To determine mechanical and set up notch filter parameters to suppress vibration caused by resonance.

The screenshot displays the 'Mechanical Properties Analysis' window. It features two primary plots: 'Amplitude (dB)' vs 'Frequency' (log scale) and 'Phase (deg)' vs 'Frequency' (log scale). The Amplitude plot shows a resonance peak at approximately 200 Hz. The Phase plot shows a phase shift of about 180 degrees at the same frequency. The right panel contains notch filter design parameters for Notch filter 1 through 6, including resonant frequency, Q value, and anti-resonant frequency. The bottom panel includes excitation amp settings (Distance, Velocity, Acceleration) and notch filter settings (Target, Resonant, Antiresonant).

To avoid strong vibration, please first set lower excitation amplitude. However, if the set value is too low, data waveform will include some degree of distortion.

If vibration occurs during tests which can't be reduce through lowering electrical current excitation, it might be due to excessive gain. Please lower velocity gain and set notch filter as accordance from the mechanical properties analysis. Or might be due to inertia settings (Pr0.04) is too large, please use optimal inertia ratio value.

Click on “Start” to start mechanical properties analysis. Click on Notch Filter Design to get the identified notch filter settings. Use the arrow keys on the right panel to save the parameters to driver. Notch filter 1 and 2 is available on all servo drive models while notch filter 5 and 6 is model dependent. All analysis can be saved and read as .mch files.

To manually tune notch filter

1. Perform resonance frequency analysis.

To perform resonance frequency analysis

- a. Through Motion Studio 2 – Mechanical properties analysis
 - b. By setting Pr2.00 = 1, resonant frequency will be detected automatically when servo motor runs, the result will be saved into 3rd notch filter. Fill the parameter values from 3rd notch filter into the rest of the notch filters, then measure resonant frequency again.
2. Set actual occurring resonance frequency as notch filter resonant frequency.

3. Set the frequency obtained from step 1 into notch filter parameter value settings. Please set the width and depth of the notch filter as well.
4. If resonance is successfully suppressed, it means notch filter has taken effect. Please do continue to fine tune gain. As gain value increases, resonance might occur again. If so, please repeat the above steps.
**If resonance persists over prolonged period of time during tuning, please disable servo drive.*

Notch Filter Width

Notch filter width level is equivalent to the ratio of notch filter width and notch filter center frequency.

$$\text{Notch filter width level} = \frac{fH - fL}{fT}$$

fT : Notch filter center frequency, which is mechanical resonant frequency

$fH-fL$: Notch filter width. Corresponding to center frequency with decay amplitude of -3dB frequency bandwidth

Notch Filter Depth

Notch filter depth level is the ratio of input and output at center frequency. When notch filter depth level = 0, input at center frequency is totally suppressed; When it is = 100, input is totally free to go through. As so, the low the set value, the lower the depth of notch filter and suppression of mechanical resonance improves as well but it might cause system instability. Please use with caution.

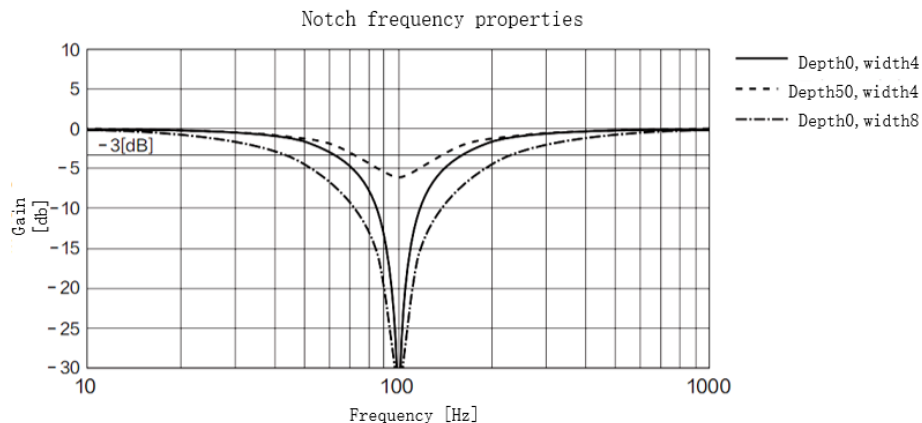

****If there is no obvious peak from mechanical properties analysis but vibration still occurs. It might be that the vibration is due to gain settings reaching its limit and not due to resonance. Please reduce gain or torque command filter time to reduce vibration.*

***Please set the frequency of the notch filter to at least 4 times of the velocity loop frequency response as wrongly set notch filter frequency might cause mechanical damage to the servo system.*

**Please only set notch filter when servo motor is totally at stop.*

State Monitor

The difference between short interval monitoring and general monitoring is the data sampling time interval. All data/variables can be added or removed from each monitoring list and the time intervals can be modified according to users' needs. We have added more useful variables in Motion Studio 2.

Short Interval monitoring: Sampling time interval of 50-200ms per cycle.

General monitoring: Sampling time interval 300ms up to 5000ms per cycle.

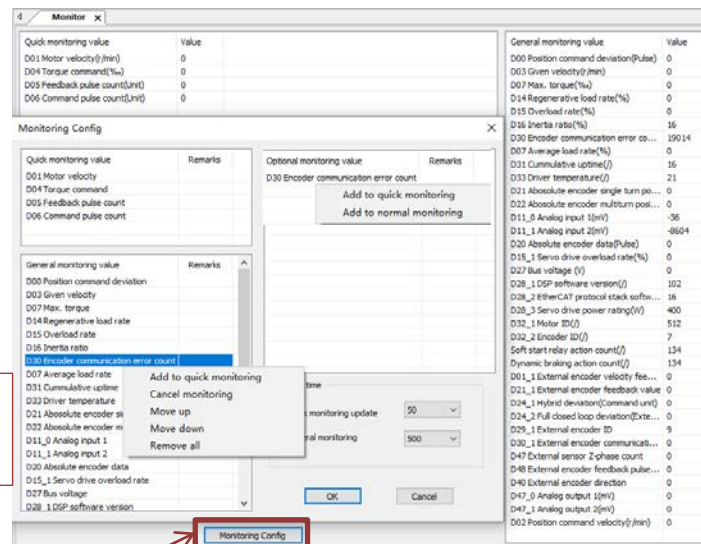

Add variables to required monitoring mode

Right click on variable to add, remove or rearrange variables in the list

Click to start State Monitor configuration.

Set sampling time interval for 2 different modes

Error Alarm

To check error messages, causes and recommended solutions. Clear alarm after handling the error successfully. Historical records of alarms can also be found in this function. Alarms related to motor stops rotating is highlighted in different for users to easy detect the cause of error(s), solve the error and return axis to normal operational status.

Alarm

Current | History | Cause(s) of motor not rotating

Device	Alarm Code	Alarm label	Clearable	Error Level
Axis1	Err0D2	No main power supply detected	Yes	2

Click on the error in this list to get error analysis on the table below

Clear

Error Analysis

ID	Cause	Check	Handle
1	No main power supply	Verify L1,L2,L3 terminal voltage	1. Increase main power supply voltage ; 2. Secure conn...

Error Diagnostic

ID	Label	Value
----	-------	-------

Please make sure to handle alarm as recommended before clearing

Alarm

Current | History | Cause(s) of motor not rotating

Select axis: Axis1 | Clear | Generate Report

Alarm Code	Alarm label	ID	Label	Value
Err000	No alarm	0	Downtime(s)	NULL
Err000	No alarm	1	Position command velocity(rpm)	NULL
Err000	No alarm	2	Relative position deviation(P)	NULL
Err000	No alarm	3	Velocity setting(rpm)	NULL
Err000	No alarm	4	Motor velocity(rpm)	NULL
Err000	No alarm	5	Motor torque(0.1%)	NULL
Err000	No alarm	6	U/A phase current(0.1%)	NULL
Err000	No alarm	7	W/B phase current(0.1%)	NULL
Err000	No alarm	8	DC bus voltage(V)	NULL
Err000	No alarm	9	Driver/MCU temperature(°C)	NULL
Err000	No alarm	10	Command position(P)	NULL
Err000	No alarm	11	Feedback position(P)	NULL
Err000	No alarm	12	Encoder error count(Time)	NULL
Err000	No alarm	13	Max. motor current under 2s(0.1%)	NULL
Err000	No alarm	14	Motor overload ratio(%)	NULL
Err000	No alarm	15	Regenerative resistor overload ratio(%)	NULL
Err000	No alarm	16	Internal status	NULL
Err000	No alarm	17	Input status	NULL
Err000	No alarm	18	Output status	NULL
Err000	No alarm	19	Encoder status	NULL
Err000	No alarm	20	6040&6041(Control word& status word)	NULL
Err000	No alarm	21	6060&6061(Operation mode selection & display)	NULL
Err000	No alarm	22	607A (Target position)	NULL
Err000	No alarm		6064 (Actual position feedback)	NULL

Alarm historical record

Data record when alarm occurs

Error report can be generated and saved as .csv file.

Tool

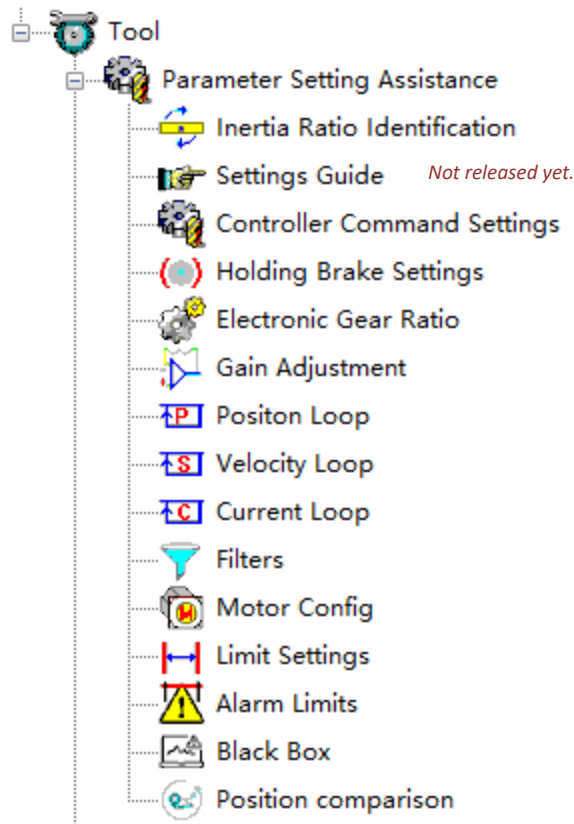

Most of the tools to tune servo drive can be found under this category. Please set up accordingly. Inertia Ratio should always be done first as it is the basis to get better results from other tuning processes. Newly added functions such as Black Box and Position Comparison in EL8 Series AC Servo Drives can be found under this category as well. Please refer to the instruction down below to set up these functions.

Inertia Ratio Identification

1. Start Motion Studio and maneuver to inertia ratio identification page under performance tuning. Set trial run velocity Pr6.04 and acc-/deceleration time Pr6.25, click on 'Download' to save parameters to servo driver.
2. Tick "External enabling disabled" and click on "Servo on".
3. Click and hold "Forward" to start the motor. Current position will show motor cycles of revolution. Click on "Position 1" to save current position as starting point. Click and hold "Reverse" to start the motor again. Click on "Position 2" to save current position as ending point.
4. Set the waiting time between each cycle in Pr6.21 and no. of cycles in Pr6.22. Click on 'Run' and motor will run according to the parameters set.

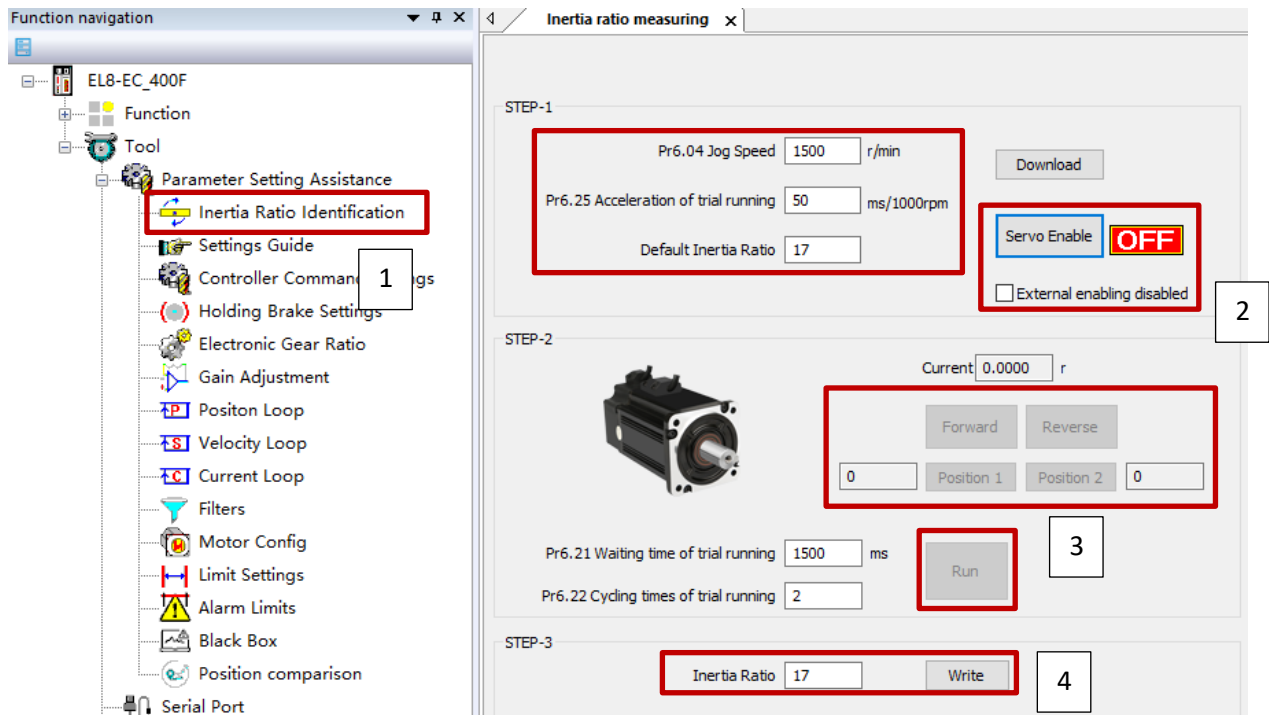

5. After the calculation is done, inertia ratio will be calculated automatically and click on 'write' to enter the calculated value into Pr0.04.

6. Click on “Parameter List” to enter parameters management to check or modify Pr0.04. Then, click on “Save” to save parameters to driver.

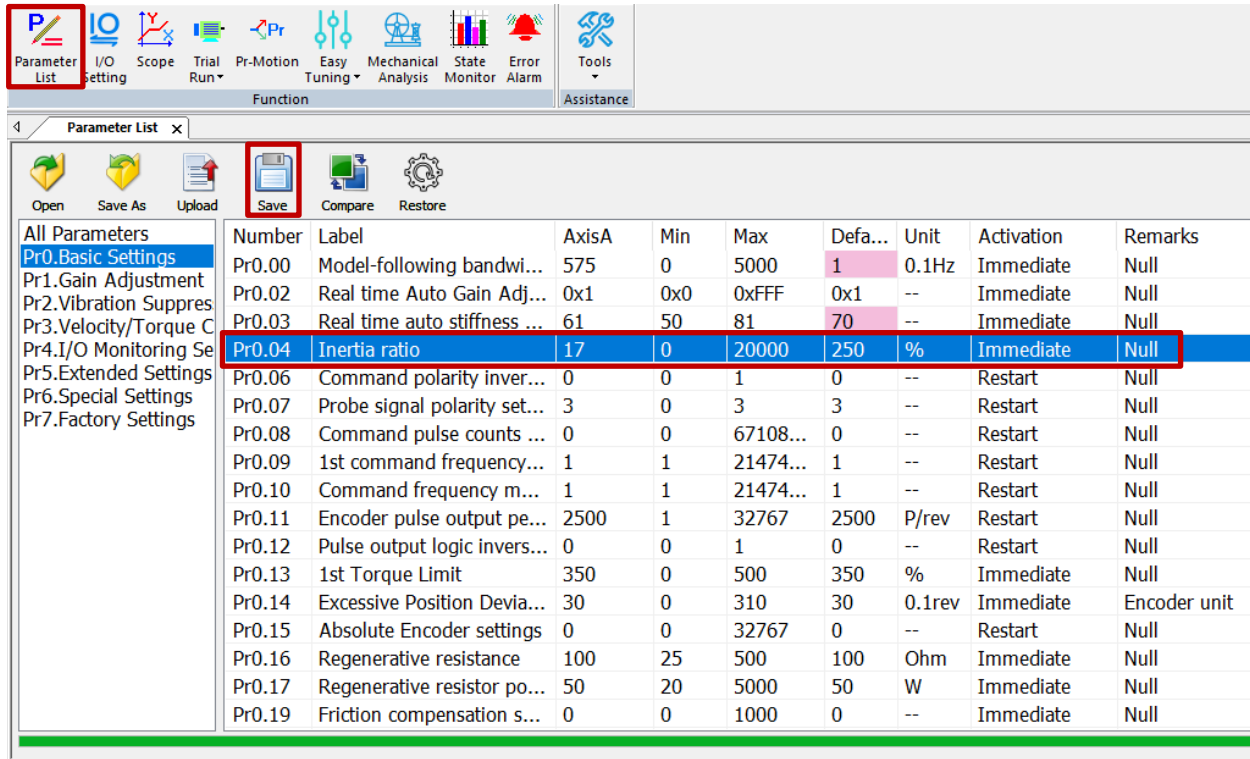

Number	Label	AxisA	Min	Max	Defa...	Unit	Activation	Remarks
Pr0.00	Model-following bandwi...	575	0	5000	1	0.1Hz	Immediate	Null
Pr0.02	Real time Auto Gain Adj...	0x1	0x0	0xFF	0x1	--	Immediate	Null
Pr0.03	Real time auto stiffness ...	61	50	81	70	--	Immediate	Null
Pr0.04	Inertia ratio	17	0	20000	250	%	Immediate	Null
Pr0.06	Command polarity inver...	0	0	1	0	--	Restart	Null
Pr0.07	Probe signal polarity set...	3	0	3	3	--	Restart	Null
Pr0.08	Command pulse counts ...	0	0	67108...	0	--	Restart	Null
Pr0.09	1st command frequency...	1	1	21474...	1	--	Restart	Null
Pr0.10	Command frequency m...	1	1	21474...	1	--	Restart	Null
Pr0.11	Encoder pulse output pe...	2500	1	32767	2500	P/rev	Restart	Null
Pr0.12	Pulse output logic invers...	0	0	1	0	--	Restart	Null
Pr0.13	1st Torque Limit	350	0	500	350	%	Immediate	Null
Pr0.14	Excessive Position Devia...	30	0	310	30	0.1rev	Immediate	Encoder unit
Pr0.15	Absolute Encoder settings	0	0	32767	0	--	Restart	Null
Pr0.16	Regenerative resistance	100	25	500	100	Ohm	Immediate	Null
Pr0.17	Regenerative resistor po...	50	20	5000	50	W	Immediate	Null
Pr0.19	Friction compensation s...	0	0	1000	0	--	Immediate	Null

Set 1st inertia ratio, the inertia ratio between load and motor rotating inertia.

Set inertia ratio according to actual load inertia.
 When both are uniform, actual motor velocity loop responsiveness and gain settings will be consistent.
 If inertia ratio is greater than actual value, velocity loop gain settings will be higher and vice versa.
 For motor with high inertia, Pr0.04 can be left unfilled but optimal setting of Pr0.04 could improve system performance.

Please take note:

1. Let motor run at above 400rpm, make sure there are acceleration, constant velocity and deceleration phase during the whole run. Cycle through 2-3 times to calculate load-inertia ratio.
2. Trial run velocity and distance should be optimal to prevent any axis from bumping into objects.
3. It is recommended to move only in 1 direction for vertically mounted axis. Take precaution before moving the axis.
4. For applications with higher frictional drag, please set a minimal travel distance.

Holding Brake Settings

To set up holding brake output signal, activation and delay time. Use only when motor comes with holding brake.

← Brake Setting ×

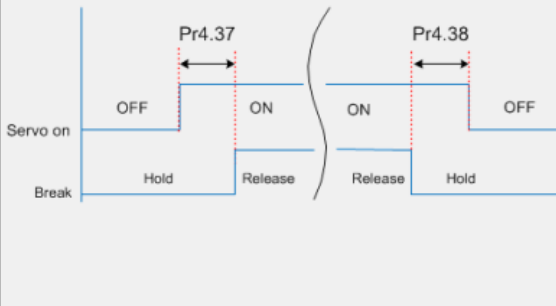

Number	Label	AxisA	Unit
Pr4.37	Motor power-off delay time	150	ms
Pr4.38	Delay time for holding brake r...	0	ms
Pr4.39	Holding brake activation speed	30	r/min
-	Holding brakeOutput	DO-1	-
-	Polarity	Normally O...	-

Electronic Gear Ratio

To set up pulses per revolution or electronic gear ratio. Calculation formulas are provided.

← Electronic Gear Ratio ×

Pulses Per Revolution 609 p

Electronic Gear Ratio

Numerator 6091-01

Denominator 6091-02

Lead screw transmission:

Pulses per revolution = Screw lead/pulse equivalent

Gear transmission:

Pulses per revolution = (modulus*number of pinion*Helical Angle*3.1415927)/(gear ratio*pulse equivalent)

Gain adjustment

Gain adjustment can be done automatically or manually. There are options for easy adjustments such as Single Parameter Tuning or One-click Tuning. Please refer to related AC servo drive series user manual for details on gain adjustment. Step-by-step guide to gain adjustment of different modes are available in product user manual. This section is only for introduction to gain and filter parameters tuning interface. Parameters descriptions are available in attached parameters file or in series specific user manual.

Gain Adjustment
✕

Gain Config

Filter Config

Number	Label	Axis1	Unit
Pr0.02.0	Motion Setting	2:Position	--
Pr0.02.1	Load Setting	0:Rigid structu...	--
Pr0.03	Real time auto stif...		--
Pr1.00	1st position loop g...	480	0.1/s
Pr1.01	1st velocity loop g...	270	0.1Hz
Pr1.02	1st Integral Time ...	210	0.1ms
Pr1.03	1st velocity detecti...	15	--
Pr1.04	1st Torque Filter T...	84	0.01ms
Pr1.05	2nd Position Loop...	570	0.1/s
Pr1.06	2nd velocity loop ...	270	0.1Hz
Pr1.07	2nd Integral Time ...	10000	0.1ms

Notch Filter

Vibration Filter

Number	Label	Axis1	Unit
Pr2.00	Adaptive filtering ...	0:Disable auto...	--
Pr2.01	1st notch frequency	2000	Hz
Pr2.02	1st notch bandwid...	2	--
Pr2.03	1st notch depth se...	0	--
Pr2.04	2nd notch frequen...	2000	Hz
Pr2.05	2nd notch bandwi...	2	--
Pr2.06	2nd notch depth s...	0	--
Pr2.07	3rd notch frequency	2000	Hz
Pr2.08	3rd notch bandwi...	2	--

Pr0.01 Control mode
9:EtherCAT

Pr0.04 Inertia ratio

OK

OK

Click on "OK" to save modified parameters.

Position Loop

To set up position loop control related parameters.

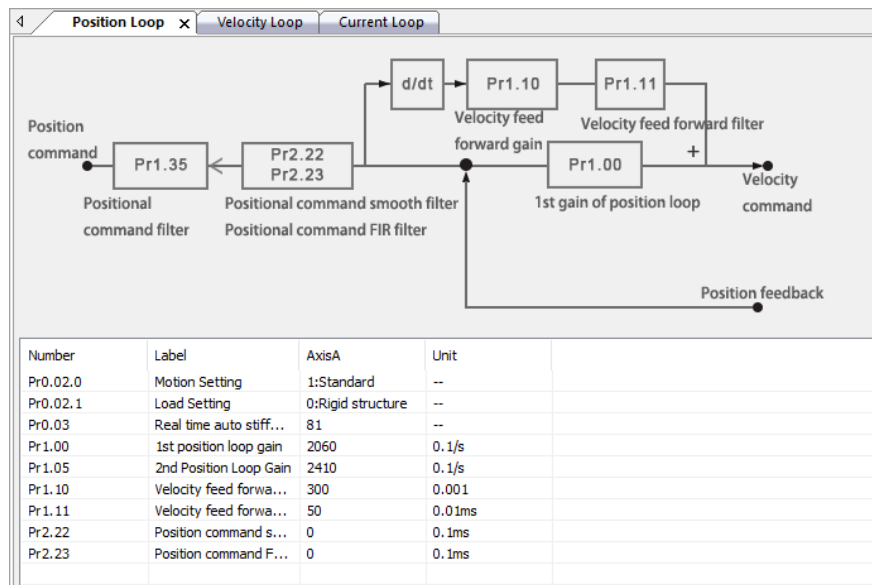

Velocity Loop

To set up velocity loop control related parameters.

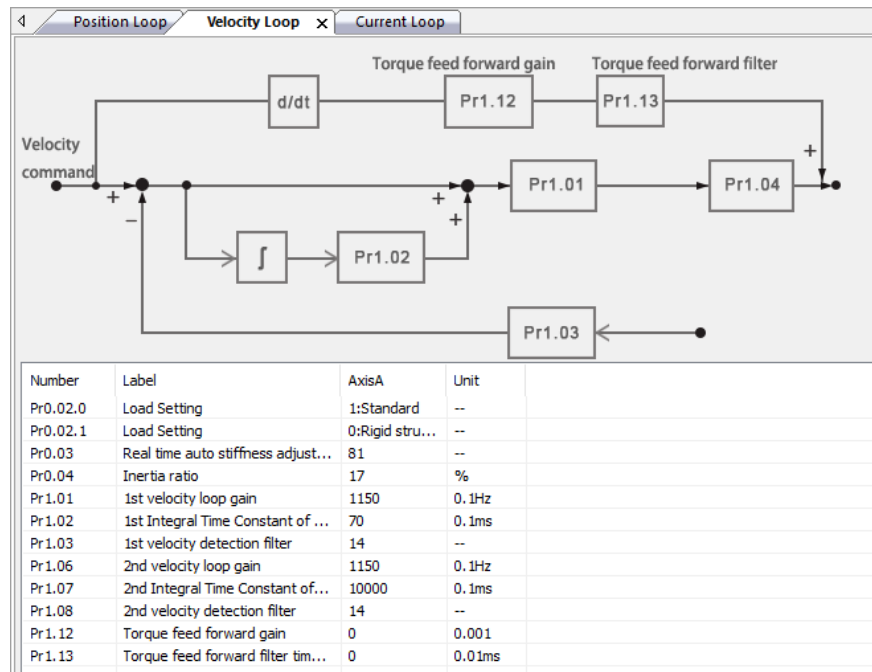

Current Loop (Torque Loop)

To set up current loop (Torque loop) related parameters. Notch filters can be activated if vibration suppression is required. Pr2.01 - Pr2.06 are valid if Pr2.00 adaptive filtering mode is disabled.

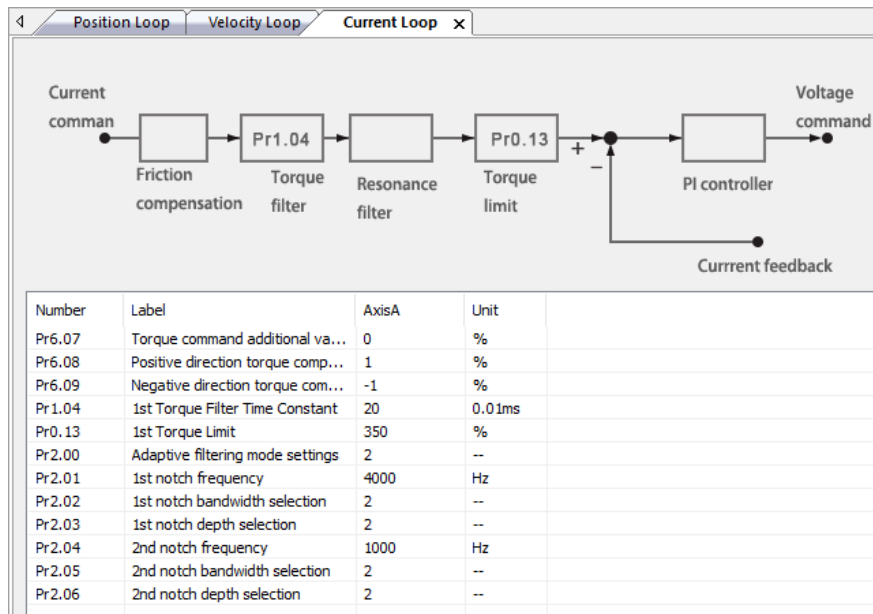

Motor Config. (Encoder Settings)

Set up absolute encoder related settings on Absolute Encoder page. For other types of encoder, encoder model and related parameters can be set up on Motor Angle Encoder page. Set up Pr6.01 Encoder Zero Position to perform encoder zero correction if necessary.

Encoder Setting x

Absolute Encoder | Motor Angle Encoder

Pr7.16 Encoder

Pr0.15 Absolute

Pr5.20 Position setup unit

OK

Encoder Setting x

Absolute Encoder | Motor Angle Encoder

Select axis

Pr7.16 Encoder model

Pr7.23 Encoder precision

Pr7.02 Motor rotor initial angle

Pr7.18 Encoder index angle

Pr6.01 Encoder zero position

Encoder identification

OK

Limit Settings

To set up positional, torque and velocity limits. Max. motor speed is the min. value of limit set in Pr7.11 and 6080h.

Number	Label	AxisA	Unit
607D-01	607D-01 Positive Limit	0	P
607D-02	607D-02 Negative Limit	0	P
Pr5.21	Torque limit selection	0	--
Pr0.13	1st Torque Limit	350	%
Pr5.22	2nd torque limit	300	%
60E0	60E0 Positive Torque Limit	7500	0.1%
60E1	60E1 Negative Torque Limit	7500	0.1%
6072	6072 Max. motor torque	7500	0.1%
6080	6080 Max. motor velocity	8000	rpm
Pr7.11	Motor maximum speed	7000	r/min

Alarm Limits

To set alarm threshold value (value which alarm occurs once exceeded).

Number	Label	AxisA	Unit
Pr7.25	Temperature setting for fan on	50	°C
Pr7.27	Driver over-temperature alarm threshold setting	105	°C
Pr7.30	Undervoltage threshold value	180	V
Pr7.34	Overvoltage threshold value	400	V
Pr7.32	Vent on threshold value settings	380	V
Pr0.16	Regenerative resistance	100	Ohm
Pr0.17	Regenerative resistor power rating	50	W
Pr7.35	Relay control mode setting	0	--
Pr7.36	Relay close threshold value	200	V
Pr0.14	Excessive Position Deviation Settings	30	0.1rev

Black Box

- Click on “Black Box” under “Tool” to enter Black box setup. There 3 methods to trigger black box function: 1. Random error, 2. Specific error, 3. Conditions triggering. Choose trigger method as accordance to needs. Please pay attention to Data Overlay Mode and choose the option needed before start.

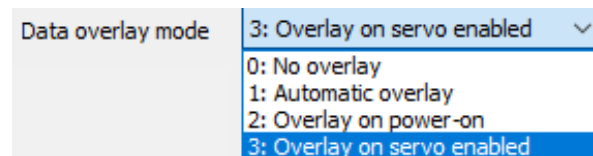
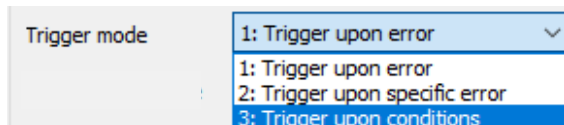
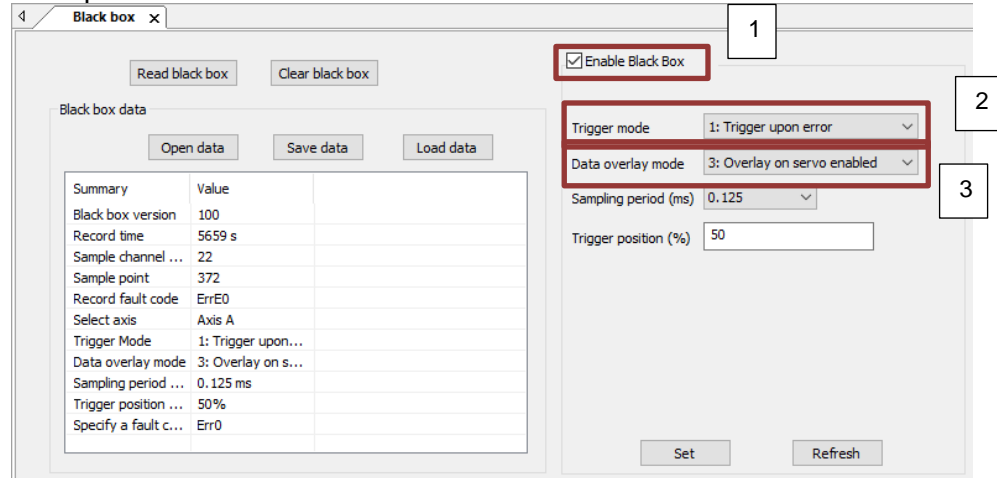

- Trigger mode 2: Trigger black box whenever a chosen specific error occurs.

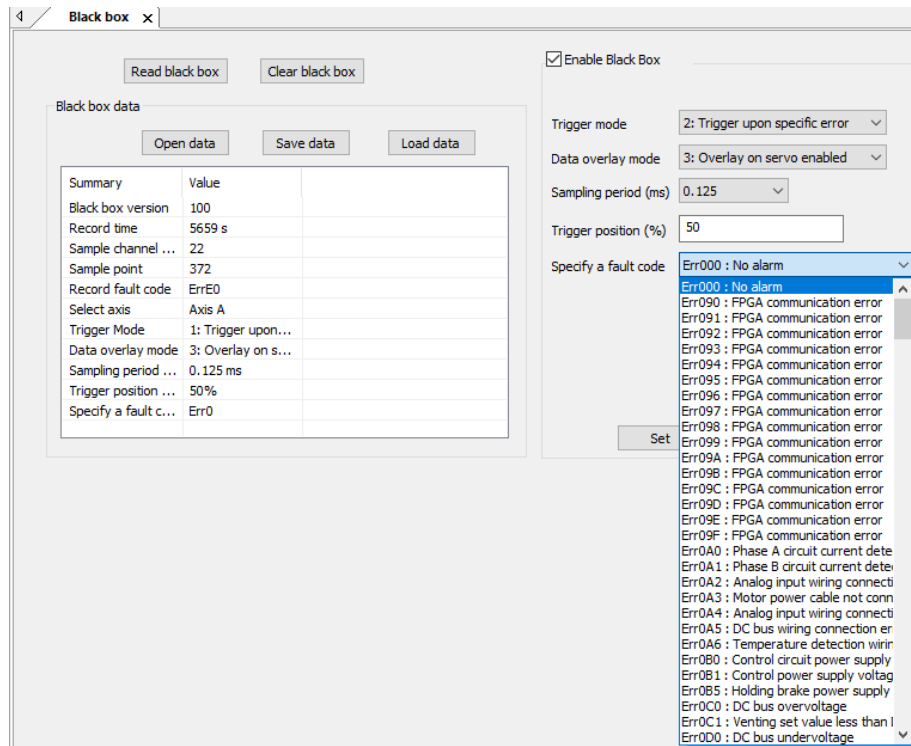

3. Trigger mode 3: Conditions for black box functions to be triggered can set. Set the source, level and edge of the trigger as shown below.

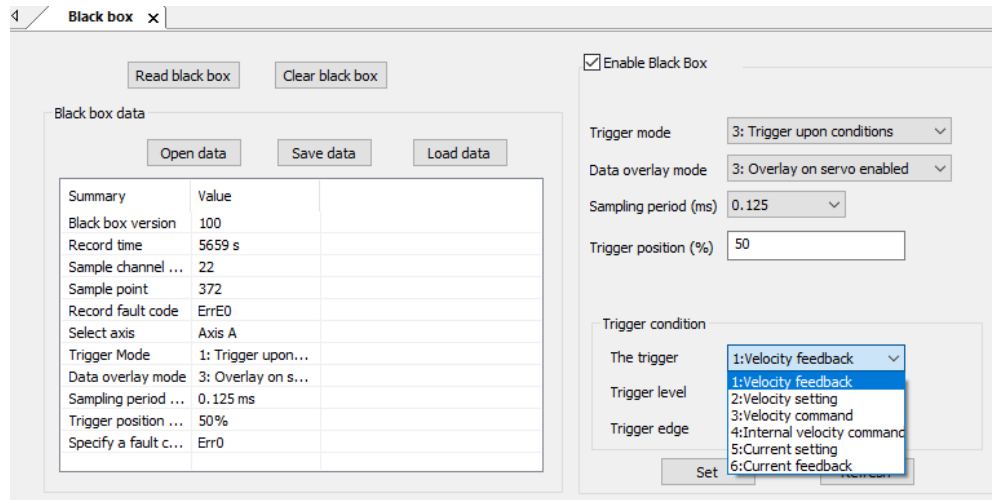

4. Data overlay mode: To select how and when black box data is overlaid. 0: Do not overlay data (Black box will only preserve the data of the first trigger). 1: Always overlay (Black box data will be overlaid every time). 2: Overlay upon powered on (Data overlaid occurs when servo drive is powered on) 3: Overlay when enabled (Data overlaid occurs when servo drive is enabled).
5. Sampling period (ms): The lower the set value, the more precise the samples are but sampling time will be shorter.
6. Trigger position (%): Set the position of trigger within the sampling period.
7. Click on “Set” to save the settings to driver.

Data recorded in Black Box can be read and cleared. The data can also be saved and read by anyone from this function interface for further analysis.

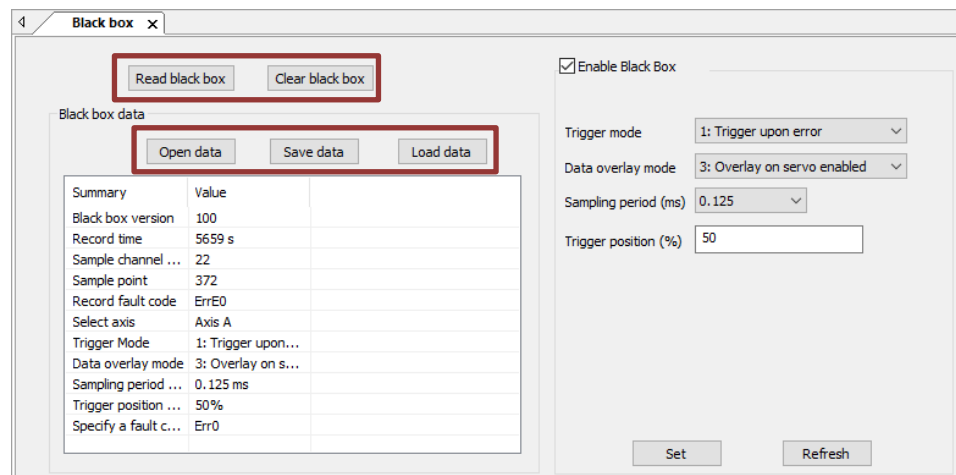

Position Comparison

Position comparison is achieved by using instantaneous position data in comparison with preset position in position parameters. When the condition(s) is fulfilled, a pulse width configurable DO signal or ABZ/OCZ signal through frequency divider will be delivered. This function is operated in CPLD, without communication delay between processors hence it is suitable for application where high velocity motion is required.

Please refer to user manual for further details.

1. Click on “Position Comparison” under Tools in Function Navigation to start the interface of position comparison function.

Single cycle position comparison

2. Enable position comparison function. Select “[0] Single cycle” for Mode and set output pulse width, start/end point as per required. Remember to click on “Download and save” to save the settings.

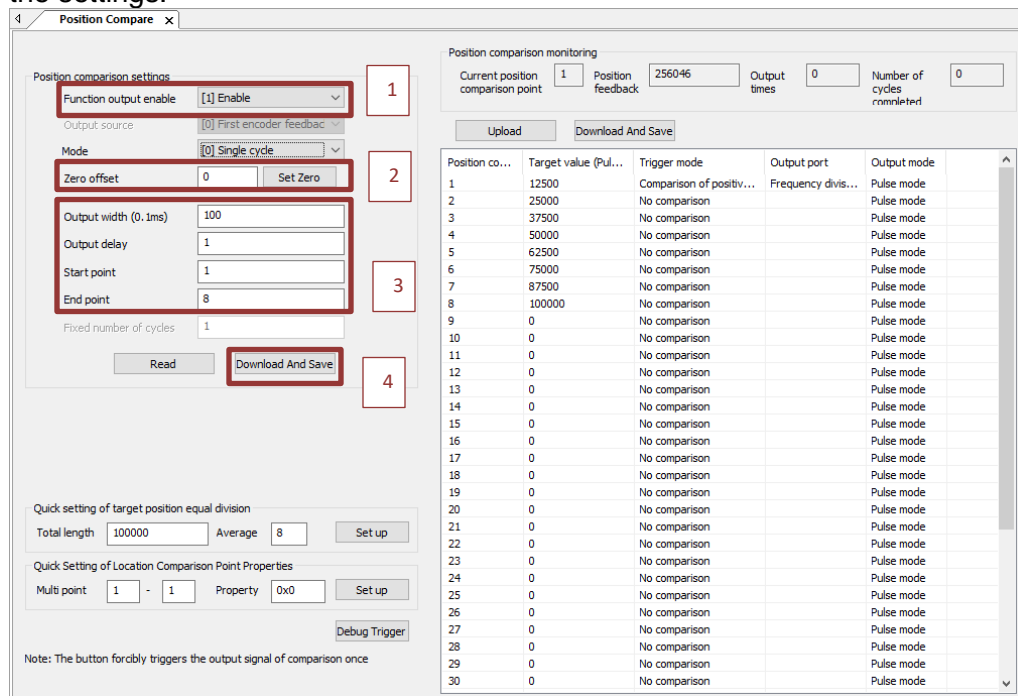

Position co...	Target value (Pul...	Trigger mode	Output port	Output mode
1	12500	Comparison of positv...	Frequency divis...	Pulse mode
2	25000	No comparison		Pulse mode
3	37500	No comparison		Pulse mode
4	50000	No comparison		Pulse mode
5	62500	No comparison		Pulse mode
6	75000	No comparison		Pulse mode
7	87500	No comparison		Pulse mode
8	100000	No comparison		Pulse mode
9	0	No comparison		Pulse mode
10	0	No comparison		Pulse mode
11	0	No comparison		Pulse mode
12	0	No comparison		Pulse mode
13	0	No comparison		Pulse mode
14	0	No comparison		Pulse mode
15	0	No comparison		Pulse mode
16	0	No comparison		Pulse mode
17	0	No comparison		Pulse mode
18	0	No comparison		Pulse mode
19	0	No comparison		Pulse mode
20	0	No comparison		Pulse mode
21	0	No comparison		Pulse mode
22	0	No comparison		Pulse mode
23	0	No comparison		Pulse mode
24	0	No comparison		Pulse mode
25	0	No comparison		Pulse mode
26	0	No comparison		Pulse mode
27	0	No comparison		Pulse mode
28	0	No comparison		Pulse mode
29	0	No comparison		Pulse mode
30	0	No comparison		Pulse mode

Motion Studio 2 User Manual

- For example to set up 8 points of comparison with equivalent distance between each points of comparison.

N = points of comparison

d = distance between each points

Total length = $8 * d$

Target value of each point = $N * d$

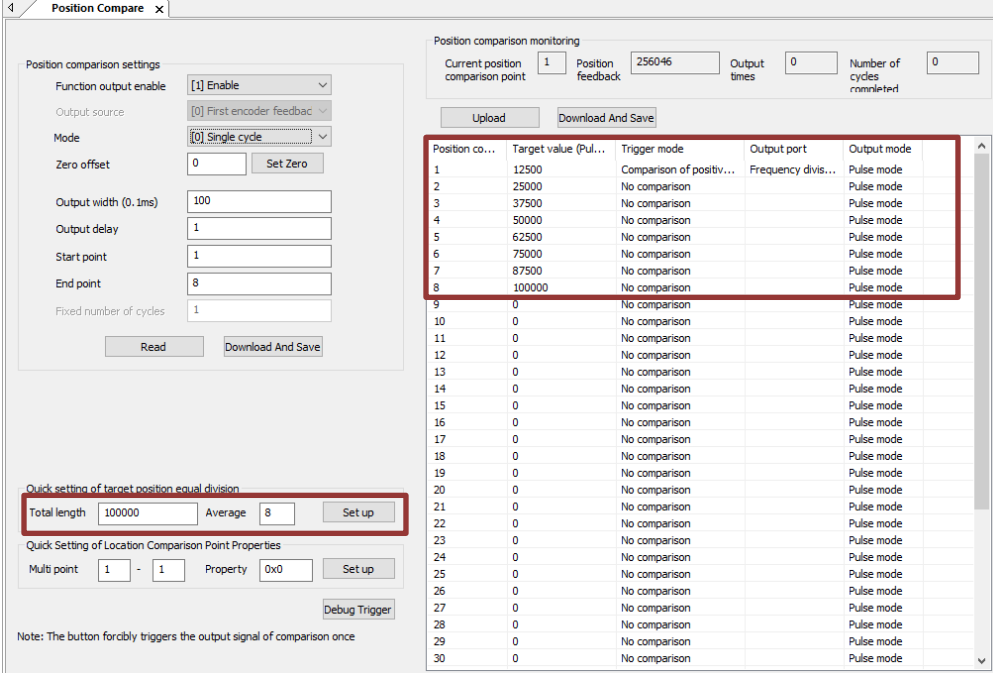

The screenshot shows the 'Position Compare' window. On the left, 'Position comparison settings' are configured: Function output enable is [1] Enable, Output source is [0] First encoder feedback, Mode is [0] Single cycle, Zero offset is 0, Output width (0.1ms) is 100, Output delay is 1, Start point is 1, End point is 8, and Fixed number of cycles is 1. Below this, 'Quick setting of target position equal division' is set with Total length 100000 and Average 8. 'Quick Setting of Location Comparison Point Properties' shows Multi point 1 - 1 and Property 0x0. On the right, 'Position comparison monitoring' shows Current position comparison point 1, Position feedback 256046, Output times 0, and Number of cycles completed 0. A table lists 30 comparison points:

Position co...	Target value (Pul...	Trigger mode	Output port	Output mode
1	12500	Comparison of positiv...	Frequency divis...	Pulse mode
2	25000	No comparison		Pulse mode
3	37500	No comparison		Pulse mode
4	50000	No comparison		Pulse mode
5	62500	No comparison		Pulse mode
6	75000	No comparison		Pulse mode
7	87500	No comparison		Pulse mode
8	100000	No comparison		Pulse mode
9	0	No comparison		Pulse mode
10	0	No comparison		Pulse mode
11	0	No comparison		Pulse mode
12	0	No comparison		Pulse mode
13	0	No comparison		Pulse mode
14	0	No comparison		Pulse mode
15	0	No comparison		Pulse mode
16	0	No comparison		Pulse mode
17	0	No comparison		Pulse mode
18	0	No comparison		Pulse mode
19	0	No comparison		Pulse mode
20	0	No comparison		Pulse mode
21	0	No comparison		Pulse mode
22	0	No comparison		Pulse mode
23	0	No comparison		Pulse mode
24	0	No comparison		Pulse mode
25	0	No comparison		Pulse mode
26	0	No comparison		Pulse mode
27	0	No comparison		Pulse mode
28	0	No comparison		Pulse mode
29	0	No comparison		Pulse mode
30	0	No comparison		Pulse mode

Triggering mode, output port and output mode of specific point of position comparison can also be set accordingly. Position comparison signal turns from 0 to 1 (rising edge position comparison output signal). Current point of position comparison changes from 0 to the starting point set in point 1, position comparison will be made to this point. When feedback position reached point 1, current point of position comparison will change to the next point in the list.

Fixed number of cycles/Cycle mode

- Select "[1] Fixed number of cycles" to set numbers of cycles of position comparison as required or "[2] Cycle mode" for continuous cycles of position comparison.

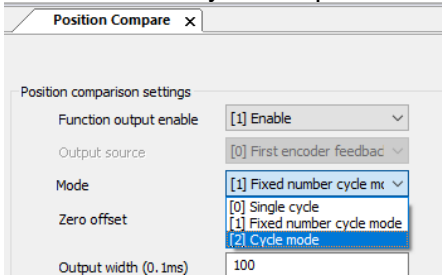

The screenshot shows the 'Position Compare' window with the 'Mode' dropdown menu open. The options are: [1] Fixed number cycle mode (highlighted), [0] Single cycle, [1] Fixed number cycle mode, and [2] Cycle mode.

- Setting up points of position comparison is the same as single cycle as shown in Step 3.

6. Position comparison signal turns from 0 to 1 (rising edge position comparison output signal). Current point of position comparison changes from 0 to the starting point set in point 1, position comparison will be made to this point. When feedback position reached point 1, current point of position comparison will change to the next point in the list. Please refer to the diagram shown below:

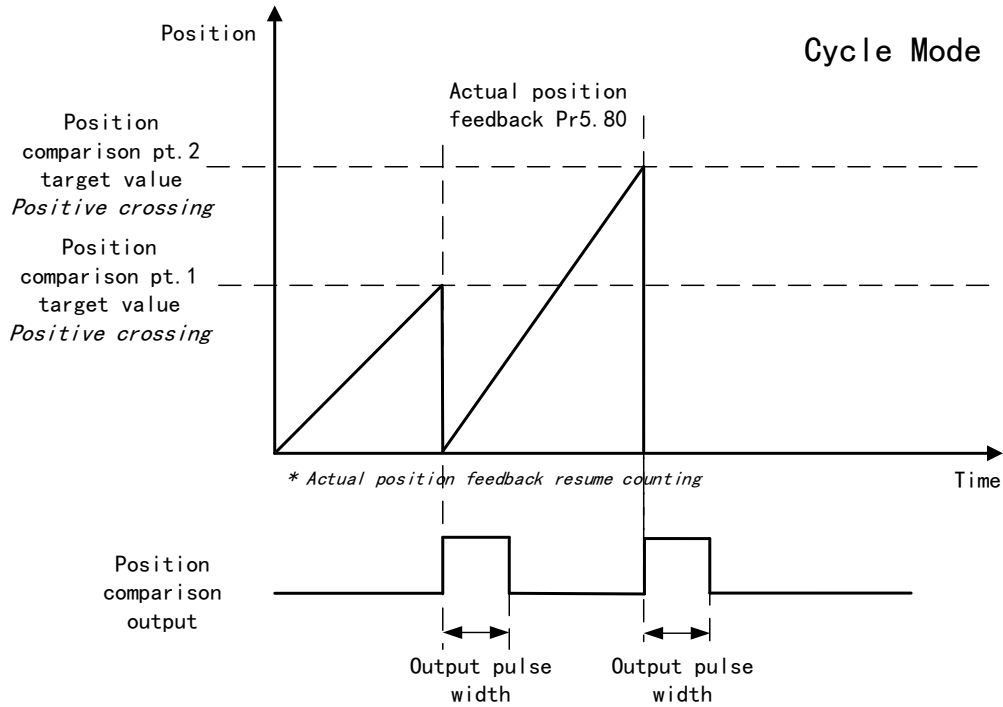

EtherCAT

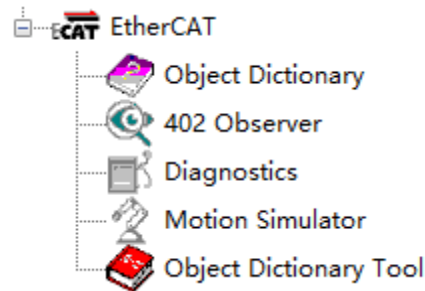

EtherCAT configuration is AC Servo Drive models specific. It will only appear when a servo drive that supports EtherCAT communication protocol is connected. Otherwise, it would be hidden automatically. Please refer to our user manual for further details on how to configure EtherCAT communication and relevant parameters.

Object Dictionary

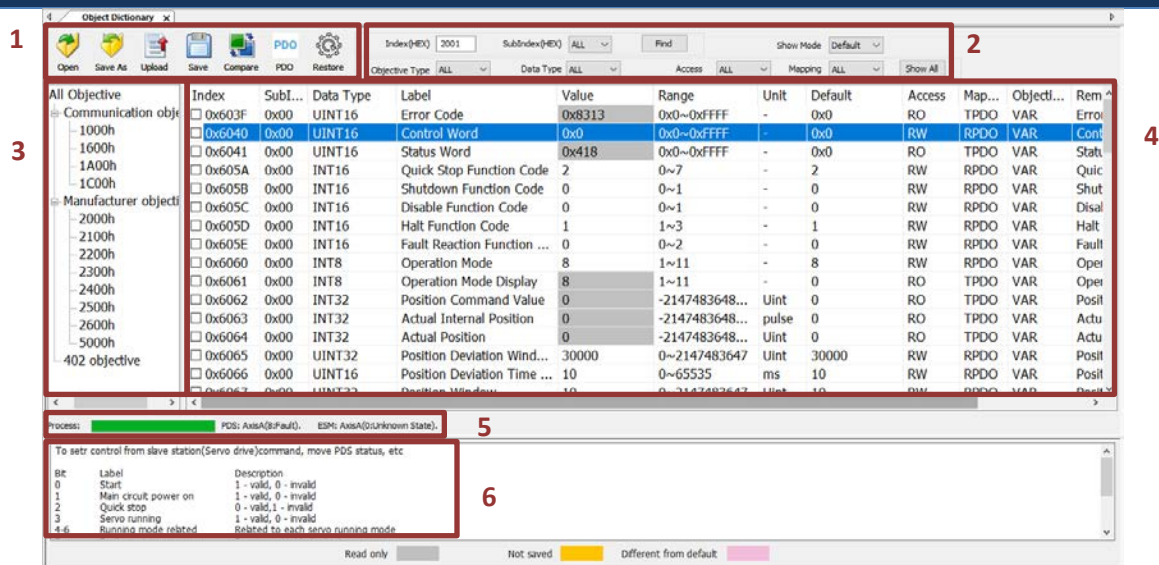

1	Function buttons	To read or save object value settings as .obd files, upload and save objects to driver, compare different sets of object settings. Use "Restore" to reset ALL objects back to factory default. <i>Please note that PDO configuration is yet to be released in Motion Studio 2.</i>
2	Search & Filter	To search for object using object index or filter a particular category of objects
3	Object categories	All objects are divided into 3 categories: Communications, Manufacturer's, 402.
4	Objects	Objects details and settings can be done in this area.
5	Status bar	Process loading progress bar, PDS and ESM status messages
6	Object description	Provides short introduction to commonly used objects (only Manufacturer's and 402). Please refer to user manual for further explanations.

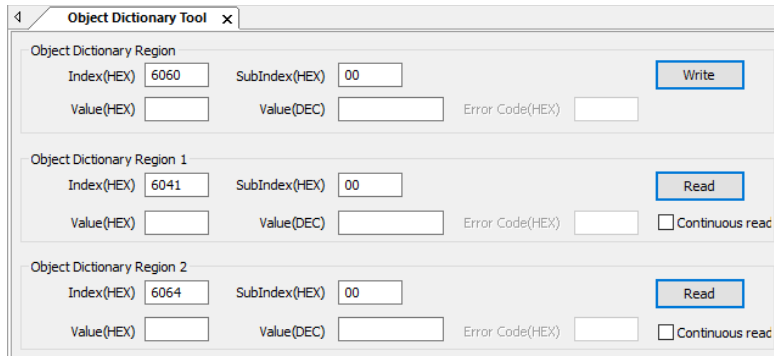

To read and write objects using object index.

402 Observer

To monitor control/status word and DI/DO state

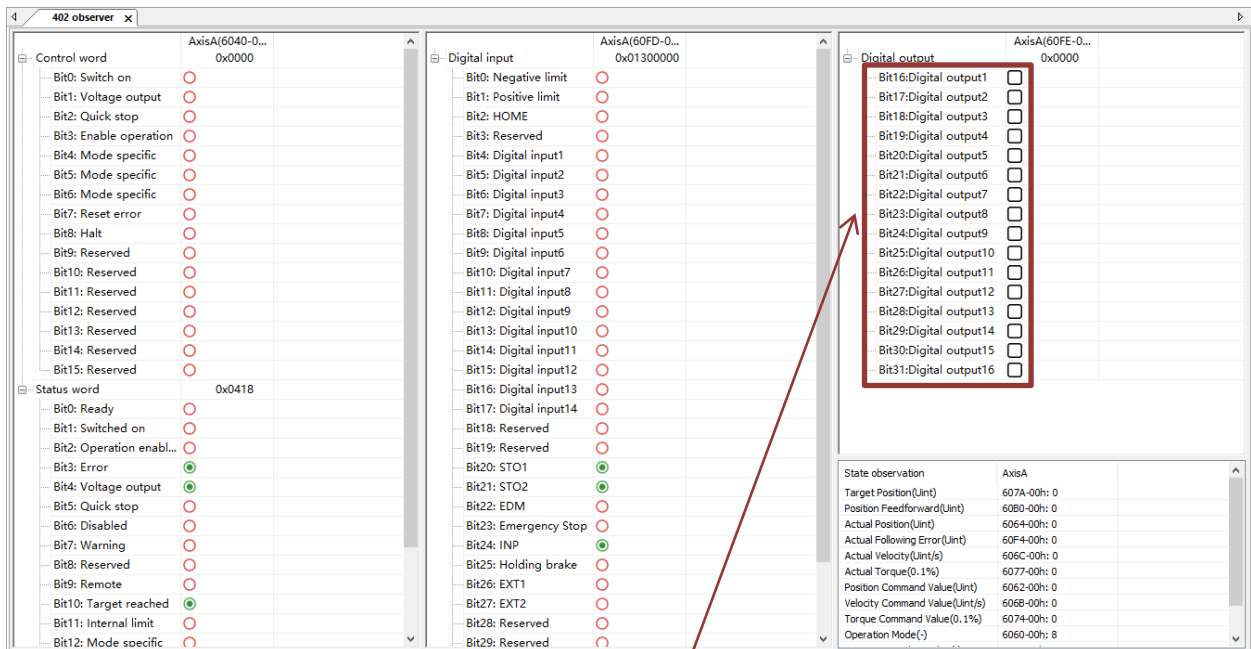

By double clicking on the checkbox, digital output state can be forced to be valid. Use for testing and tunings.

Diagnostics

Operation and Register Operation can be found here

Diagnostics			
Operation observation			
RPDO bytes:	<input type="text" value="0"/>		
TPDO bytes:	<input type="text" value="0"/>	Synchronization cycle time:	<input type="text" value="0"/> ns
SM2 lost times:	<input type="text" value="0"/>	SM2 processing time (maximum):	<input type="text" value="0"/> ns
Sync lost times:	<input type="text" value="0"/>	SM3 processing time (maximum):	<input type="text" value="0"/> ns
Synchronization overflow times:	<input type="text" value="0"/>	SM2-Sync interval (minimum):	<input type="text" value="-1"/> ns
Synchronization offset too short times:	<input type="text" value="0"/>	Sync0 offset time (maximum):	<input type="text" value="0"/> ns
Synchronous drift overload times:	<input type="text" value="0"/>	Synchronization type:	<input type="button" value="Free Run"/>
Register observation			
Port 0 invalid frame count (300h):	<input type="text" value="0"/>	Port 1 invalid frame count (302h):	<input type="text" value="0"/>
Port 0 receive error count (301h):	<input type="text" value="0"/>	Port 1 receive error count (303h):	<input type="text" value="0"/>
Port 0 forwarding error count (308h):	<input type="text" value="0"/>	Port 1 forwarding error count (309h):	<input type="text" value="0"/>
EPU error count (30ch):	<input type="text" value="0"/>	PDI error count (30dh):	<input type="text" value="0"/>
Port 0 link loss count (310h):	<input type="text" value="0"/>	Port 1 link loss count (311h):	<input type="text" value="0"/>

Contact Us

Leadshine Technology Co., Ltd.

Headquarters

Address:

15-20/F, Block B, Nanshan I Valley, No.3157, Nanshan District, Shenzhen City, Guangdong Province, China

Tel:

+86 755 26411692

Fax:

+86 755 26402718

Website:

www.leadshine.com

Emails

sales@leadshine.com

Leadshine Global Retailers Network



Get in touch with us or any of your local Leadshine certified retailers by visiting our global website.

Technical Support

Tel: 86-755-2641-8447

86-755-2641-8774 (Asia, Australia, Africa)

86-755-2665-5136 (North and South America)

86-755-8654-2465 (Europe)

Fax: 86-755-2640-2718

Email: tech@leadshine.com

Sales Hot Line

Tel: 86-755-2641-7674 (Asia, Australia, Africa)

86-755-2641-7617 (North and South America)

86-755-2640-9254 (Europe)

Email: sales@leadshine.com

Leadshine Overseas



Leadshine America, Inc.

North America

Office

Address:

26050 Towne

Centre Dr.

Foothill

Ranch California

United States

Tel:

1-949-608-7270

Fax:

1-949-638-7298

Website:

www.leadshineusa.com

Emails:

sales@leadshineusa.com