

iST-17 Series Integrated Stepper Motor

Motor + Drive, 18-38VDC, NEMA17, 0.3-0.6Nm

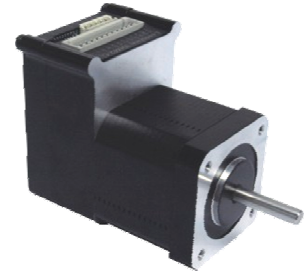

Features

- | Integrated compact size for saving mounting space & setup time, and reducing electrical interference
- | Anti-Resonance provides optimal torque and nulls mid-range instability
- | Motor auto-identification and parameter auto-configuration technology
- | Multi-Stepping allows a low resolution step input to produce a higher microstep output
- | Smooth motor movement with no vibration
- | Input voltage from 18 to 38 VDC (20-24VDC recommended)
- | Motor current programmable, from 0.5A to 3.0A.
- | 0.3-0.6 Nm (42-84 oz-in) holding torque stepper motor with NEMA 17 frame size installation
- | 15 micro step resolution options via DIP switches; or any value from 200-102,400 (increased by 1) via software configuration
- | Soft-start with no “jump” when powered on
- | Automatic idle-current reduction (Reduction rate can be software configured)
- | Isolated control inputs of Pulse, Direction and Enable
- | Pulse input frequency can be 200K or 500K (Software-configured)
- | Pulse input mode can be PUL/DIR or CW/CCW (Software-configured)
- | Fault outputs to external motion controllers for complete system controls.
- | Over voltage and over-current protection

Descriptions

Leadshine's iST-17xx integrated stepper is a NEMA 17 stepper motor integrated with an advanced DSP stepper drive. At very compact size and with all components integrated, the iST-17xx can save mounting space, eliminate motor wiring time, reduce interference, and cut/reduce cable and labor costs. By adopting Leadshine's latest current control technology, the drive of the iST-17xx can drive the stepper motor with high precision, smooth movement, and extra low noise at low speed movement with no obvious resonance area.

Applications

Leadshine's iST-17xx can be used in various applications such as laser cutters, laser markers, high precision X-Y tables, labeling machines, CNC router, etc. Its unique features make the iST-17xx an ideal choice for applications that require both low-speed smoothness and small mounting space.

Specifications

Electrical Specifications of Drive

Parameter	Min	Typical	Max	Unit
Input Voltage	18	24	38	VDC
Output Current	0	-	4.2(Peak)	A
Pulse Input Frequency	0	200	500	kHz
Pulse Voltage	3.3	5	24	V
Logic Signal Current	7	10	16	mA
Isolation Resistance	100	-	-	MΩ

Operating Environment

Cooling	Natural Cooling or Forced cooling	
Operating Environment	Environment	Avoid dust, oil fog and corrosive gases
	Ambient Temperature	0°C — 40°C (32°F — 104°F)
	Humidity	40%RH — 90%RH
	Operating Temperature (Heat Sink)	70°C (158°F) Max
Storage Temperature	-20°C-65°C (-4°F - 149°F)	

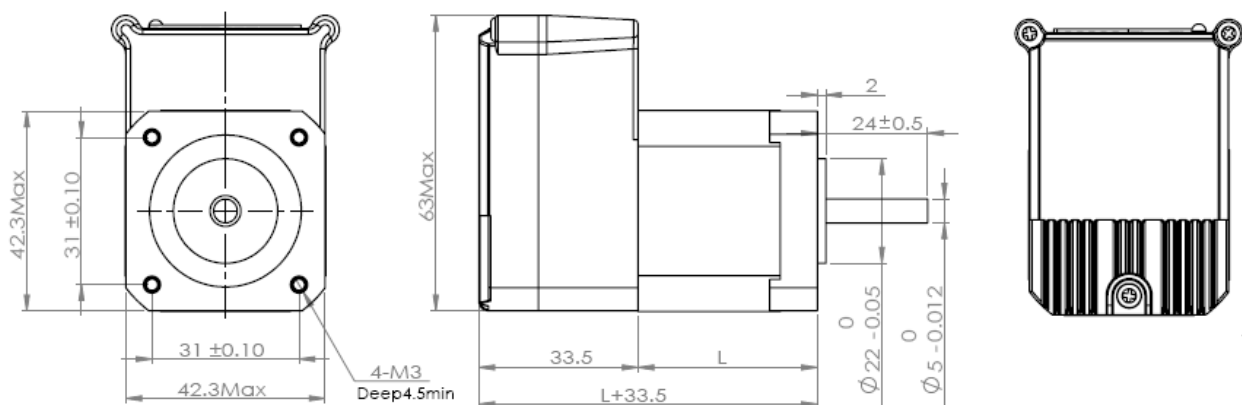

Mechanical Specifications

Part Number	Holding Torque	Motor Length (L)	Length of Motor + Drive	Weight
iST-1703	0.3Nm	39mm	72.5mm	0.44 Kg
iST-1706	0.6Nm	49mm	82.5mm	-



Protection Indications

The green light turns on when the iST-17xx is powered on and functions normally. In any case that drive protection is activated, the red LED blinks periodically (in every 3 seconds) to indicate the error type. In each blink, red light is on for 0.2 second and then off for 0.3 second.

Priority	Time(s) of Blink	Sequence wave of red LED	Description
1st	1		Over-current protection activated when peak current is greater than 7A
2nd	2		Over-voltage protection activated when drive working voltage is greater than 60±2 VDC

Connectors and Pin Assignment

Leadshine's iST-17xx has two connectors, a connector for power & control signals connections and a connector for RS232 communication connections.

Power & Control Signal Connector			
Pin	Name	I/O	Description
1	PUL+	I	<u>Pulse Signal</u> : In single pulse (pulse/direction) mode, this input represents pulse signal, active at each rising or falling edge (Set by DIP switch S6). In double pulse mode (software configurable), this input represents clockwise (CW) pulse, active both at each high level and low level. 4.5-24V for PUL-HIGH, 0-0.5V for PUL-LOW. For reliable response, pulse width should be longer than 2.5μs for 200K MAX input frequency or 1μs for 500K MAX input frequency.
2	PUL-	I	
3	DIR+	I	<u>Direction Signal</u> : In single-pulse mode, this signal has low/high voltage levels, representing two directions of motor rotation. In double-pulse mode (software configurable), this signal is counter-clock (CCW) pulse, active both at high level and low level. For reliable motion response, DIR signal should be ahead of PUL signal by 5μs at least. 4.5-24V for DIR-HIGH, 0-0.5V for DIR-LOW. The motor direction can also be changed by DIP switch S5.
4	DIR-	I	
5	ENA+	I	<u>Enable Signal</u> : This signal is used for enabling/disabling the drive board. By default, high level (NPN control signal) for enabling the drive board and low level for disabling the drive board. It is usually left UNCONNECTED (ENABLED). Please note that the PNP and Differential control signals are on the contrary, namely Low level for enabling. The active level of ENA signal is software configurable.
6	ENA-	I	
7	NC	-	No Connection.
8	NC	-	

Connectors and Pin Assignment (Continued)

Power & Control Signal Connector(Continued)			
Pin	Name	I/O	Description
9	ALM+	O	Alarm Signal: OC output signal, activated when one of the following protection is activated: over-voltage and over current error. They can sink or source MAX 20mA current at 24V. By default, the impedance between ALM+ and ALM- is low for normal operation and becomes high when any protection is activated. The active impedance of alarm signal is software configurable.
10	ALM-	O	
11	GND	GND	Power Ground (Negative)
12	+Vdc	I	Power Supply Input (Positive) 20-24VDC recommended, leaving reasonable reservation for voltage fluctuation and back-EMF during deceleration.

RS232 Communication Connector			
Pin	Name	I/O	Description
1	+5V	O	+5V power output (Note: Do not connect it to PC's serial port)
2	Tx	O	RS232 transmit.
3	Rx	I	RS232 receive.
4	GND	GND	Ground.
5	GND	GND	Ground.

DIP Switch Settings

Micro Step Resolution (S1-S4)

Micro step resolution of the iST-17xx can be configured via DIP switch S1-S4 or Leadshine's tuning software ProTuner. When all S1-S4 are at "ON" positions, the drive will take the micro step resolution setting set by the software (4000 by default). In this case, a user can re-configure the resolution to any value between 200 and 102,400 (increased by 1) through software. If any bit of S1-S4 is at "OFF" position, the integrated drive board will take micro step resolution setting determined by bit positions of S1-S4. Use the following table for their resolution settings via the DIP switch.

Steps/Revolution	S1	S2	S3	S4
Software Configured(Default 400)	On	On	On	On
800	Off	On	On	On
1600	On	Off	On	On
3200	Off	Off	On	On
6400	On	On	Off	On

Micro Step Resolution (S1-S4) (Continued)

Steps/Revolution	S1	S2	S3	S4
Software Configured (Default 4000)	On	On	On	On
12800	Off	On	Off	On
25600	On	Off	Off	On
51200	Off	Off	Off	On
1000	On	On	On	Off
2000	Off	On	On	Off
4000	On	Off	On	Off
5000	Off	Off	On	Off
8000	On	On	Off	Off
10000	Off	On	Off	Off
20000	On	Off	Off	Off
40000	Off	Off	Off	Off

Motor Shaft Direction (S5)

DIP switch S5 is used for changing motor shaft rotation direction. Changing position from “ON” to “OFF”, or “OFF” to “ON” will reverse rotation direction of the iST-17xx.

Active Edge of Input Pulse (S6)

DIP switch S6 is used for setting the active edge of a pulse signal. The motor shaft moves one micro step for each active pulse edge. Use the following table for your reference

S6	On	Off
	Active rising edge of input pulse	Active falling edge of input pulse

Self-Test (S7)

By default, DIP switch S7 is OFF and the iST-17xx responds to any pulse input. If it is turned ON, the iST-17xx goes into self-test mode. In self-test mode, the motor shaft rotates 5/4 revolutions CW and then 5/4 revolutions CCW. The self-motion repeats until S7 is turned OFF (the motor shaft will stop immediately). Note that you are unable to communicate with the iST-17xx via the RS232 port when it is in self-test mode.

Auto Current Reduction (S8)

DIP switch S8 is used to enable or disable the auto current reduction when there is no pulse applied to the iST-17xx.

S8	On	Off
	Disable auto current reduction.	Enable auto current reduction. The reduction rate is software-configurable and its default value is 50%.

Fine Tuning

Leadshine already loads default current-loop parameters for the iST-17xx. Those default parameter values have been optimized. They should be good enough for most industrial applications, and there is no need to tune them. However, if you want to fine tune the iST-17xx for best performance for your applications, Leadshine also offers tuning software, ProTuner, which allows you to adjust those current-loop parameters (see software manual).

Typical Connections

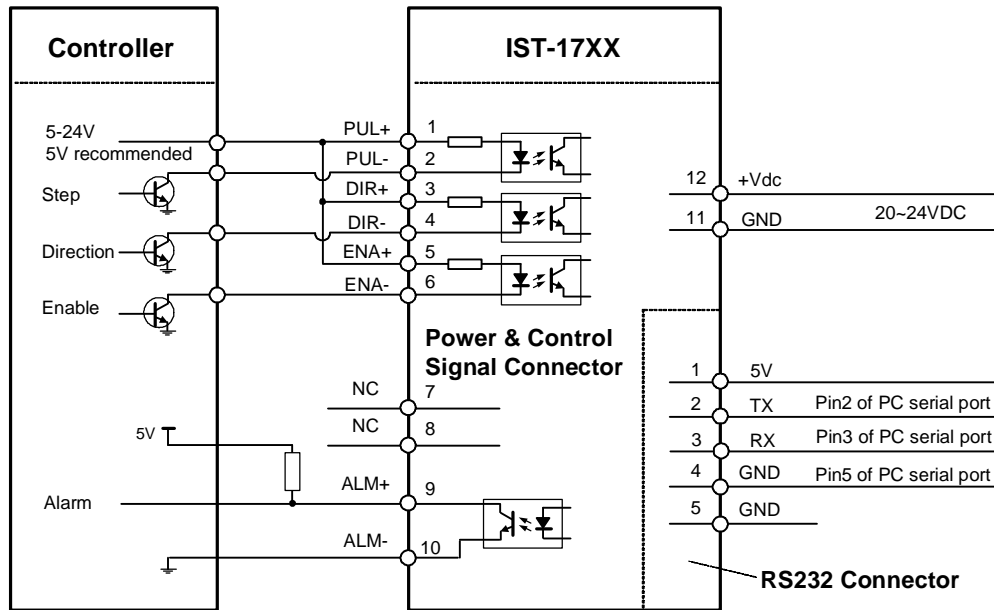

Connect IST-17XX to controller of sinking output

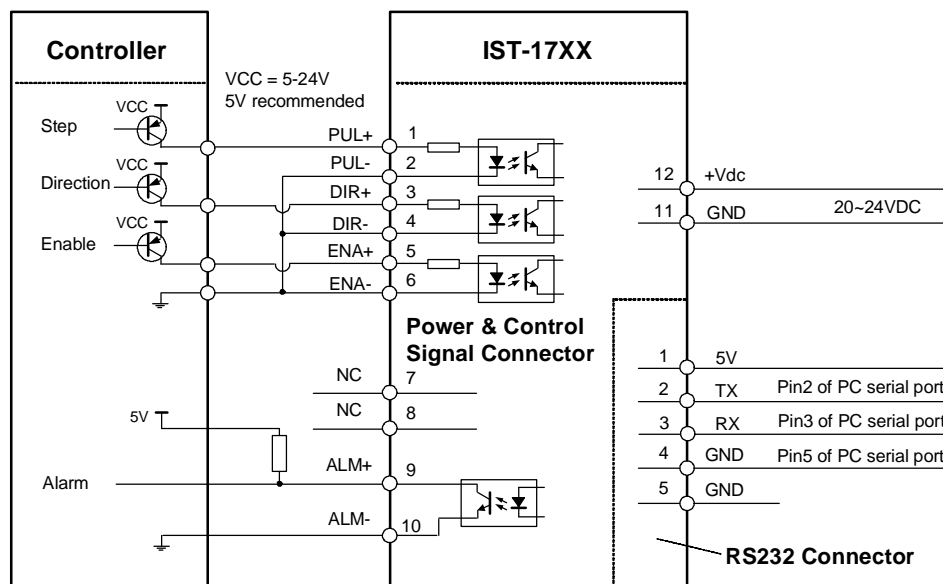

Connect IST-17XX to controller of sourcing output

Typical Connections (Continued)

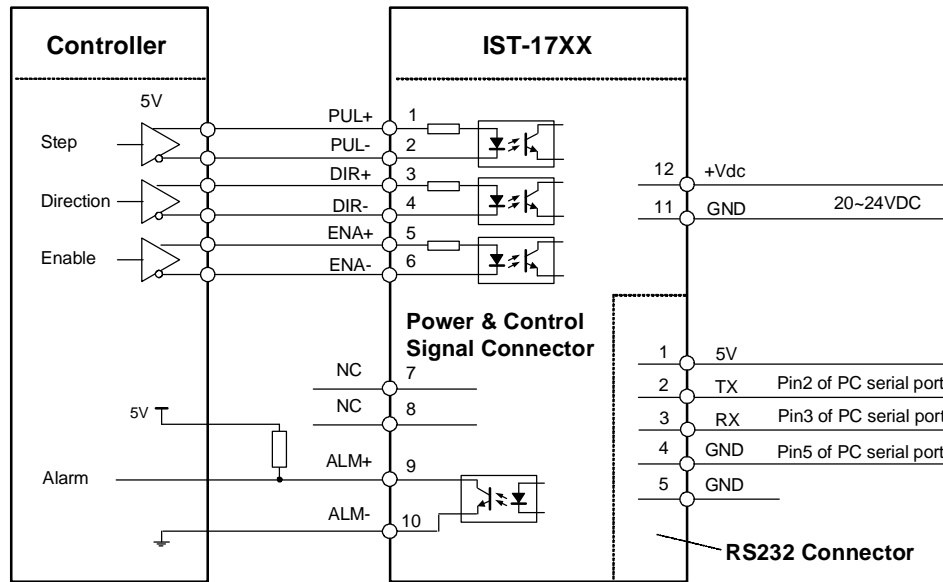

Connect IST-17XX to controller of differential output

RS232 Communication Cable Connections

Note1: The RS232 communication port is not isolated. Please use an isolated power supply for the iST-17xx when the PC's serial port is not isolated.

Note2: Do not plug or unplug the connector when power is on.

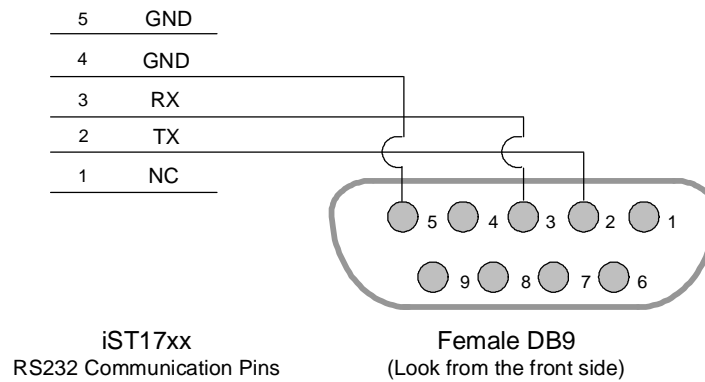

Speed-Torque Curve

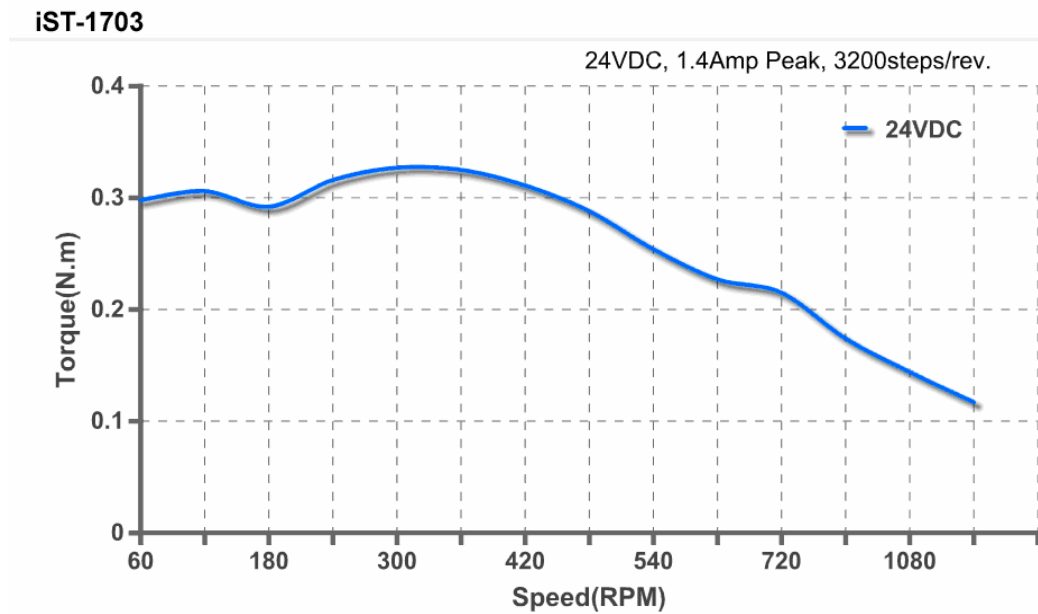

Note: The speed-torque curve is just for your reference.