

M880/M840 Microstepping Driver

1. Introduction

The M880 and the M840 are high performance microstepping drivers based on one of the most advanced technologies in the world today. They are suitable for driving 2-phase and 4-phase hybrid stepping motors. By using advanced bipolar constant-current chopping technique, they can output more speed and power from the same motor compared with traditional drivers, such as L/R drivers. Its 3-state current control technology allows coil current to be well controlled with relatively small current ripple, therefore less motor heating is achieved.



2. Features

- High performance, low cost
- Supply voltage up to +80VDC
- Output current up to 7.8A (M880), 3.9A (M840)
- Inaudible 20KHz chopping frequency
- TTL compatible and optically isolated input
- Automatic idle-current reduction
- Mixed-decay current control for less motor heating
- 14 selectable resolutions in decimal and binary, up to 51,200 steps/rev
- Suitable for 2-phase and 4-phase motors
- Over-current, over-voltage protection
- Small size

3. Applications

Suitable for a wide range of stepping motors, from NEMA size 17 to 43. It can be used in various kinds of machines, such as X-Y tables, labeling machines, laser cutters, engraving machines, pick-place devices, and so on. Particularly adapt to the applications desired with low vibration, high speed and high precision.

4. Specifications

Electrical Specifications (T_j = 25°C)

Parameters	M880/M840			Unit
	Min	Typical	Max	
Output Current	2.8/1.4	-	7.8/3.9	Amps
Supply voltage	+24	+68	+80	VDC
Logic signal current	7	10	16	mA
Pulse input frequency	0	-	300	Khz
Isolation resistance	500			MΩ

Operating Environment and other Specifications

Cooling	Natural Cooling or Forced cooling	
Operating Environment	Environment	Avoid dust, oil fog and corrosive gases
	Ambient Temperature	0°C — 50°C
	Humidity	40%RH — 90%RH
	Operating Temperature	70°C Max
	Vibration	5.9m/s ² Max
Storage Temperature	-20°C — 65°C	
Weight	Approx. 440g (15.50 oz)/M880; 330 g (11.60 oz)/M840	

Mechanical Specifications (unit:mm, 1 inch = 25.4 mm)

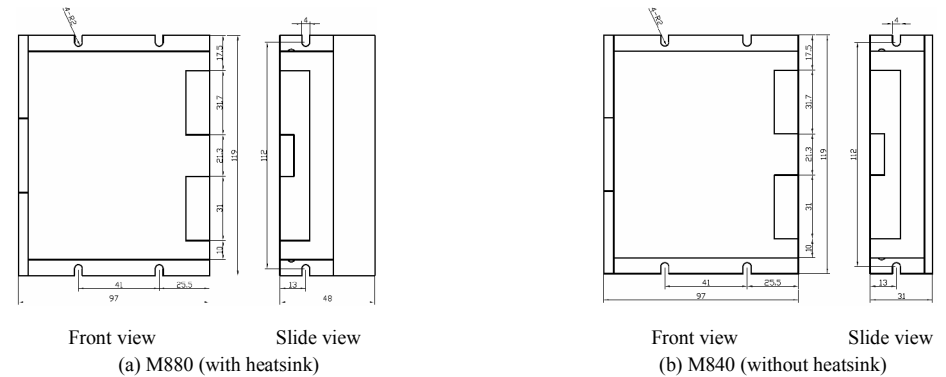

Figure 1: Mechanical specifications

*Recommend use side mounting for better heat dissipation

5. Pin Assignment and Description

The M880 and the M840 have two connectors, connector P1 for control signals connections, and connector P2 for power and motor connections. The following tables are brief descriptions of the two connectors.

Connector P1 Configurations

Pin Function	Details
PUL+(+5V)	Pulse signal: In single pulse (pulse/direction) mode, this input represents pulse signal, active at each rising or falling edge (set by inside jumper J1); 4-5V when PUL-HIGH, 0-0.5V when PUL-LOW. In double pulse mode (pulse/pulse), this input represents clockwise (CW) pulse, active at high level or low level (set by inside jumper J1). For reliable response, pulse width should be longer than 1.2μs. Series connect resistors for current-limiting when +12V or +24V used.
PUL-(PUL)	
DIR+(+5V)	DIR signal: In single-pulse mode, this signal has low/high voltage levels, representing two directions of motor rotation; in double-pulse mode (set by inside jumper J2), this signal is counter-clock (CCW) pulse, active for high level or low level (set by inside jumper J1). For reliable motion response, DIR signal should be ahead of PUL signal by 5μs at least. 4-5V when DIR-HIGH, 0-0.5V when DIR-LOW. Please note that motion direction is also related to motor-driver wiring match. Exchanging the connection of two wires for a coil to the driver will reverse motion direction.
DIR-(DIR)	
ENA+(+5V)	Enable signal: This signal is used for enabling/disabling the driver. High level (NPN control signal, PNP and Differential control signals are on the contrary, namely Low level for enabling.) for enabling the driver and low level for disabling the driver. Usually left UNCONNECTED (ENABLED) .
ENA-(ENA)	

Selecting Active Edge or Active Level and Control Signal Mode

There are two jumpers J1 and J2 inside the M880 and M840 specifically for selecting active edge or active level and control signal mode, as shown in figure 2. Default setting is PUL/DIR mode and upward-rising edge active.

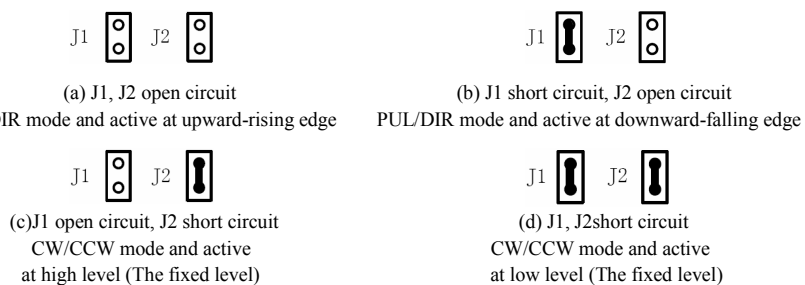

Figure 2: J1 and J2 jumpers

Connector P2 Configurations

Pin Function	Details
GND	DC power ground.
+V	DC power supply, 24-80VDC, Including voltage fluctuation and EMF voltage.
A+, A-	Motor Phase A
B+, B-	Motor Phase B

6. Selecting Microstep Resolution and Driver Output Current

This driver uses an 8-bit DIP switch to set microstep resolution, and motor operating current, as shown below:

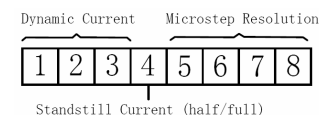

Microstep Resolution Selection

Microstep resolution is set by SW5, 6, 7, 8 of the DIP switch as shown in the following table:

Microstep	Steps/rev.(for 1.8°motor)	SW5	SW6	SW7	SW8
2	400	ON	ON	ON	ON
4	800	ON	OFF	ON	ON
8	1600	ON	ON	OFF	ON
16	3200	ON	OFF	OFF	ON
32	6400	ON	ON	ON	OFF
64	12800	ON	OFF	ON	OFF
128	25600	ON	ON	OFF	OFF
256	51200	ON	OFF	OFF	OFF
5	1000	OFF	ON	ON	ON
10	2000	OFF	OFF	ON	ON
25	5000	OFF	ON	OFF	ON
50	10000	OFF	OFF	OFF	ON
125	25000	OFF	ON	ON	OFF
250	50000	OFF	OFF	ON	OFF

Current Settings

The first three bits (SW1, 2, 3) of the DIP switch are used to set the dynamic current. Select a setting closest to your motor's required current.

Dynamic current setting

Current for M840	Current for M880	SW1	SW2	SW3
1.4A	2.8A	ON	ON	ON
1.8A	3.5A	OFF	ON	ON
2.1A	4.2A	ON	OFF	ON
2.5A	4.9A	OFF	OFF	ON
2.9A	5.7A	ON	ON	OFF
3.2A	6.4A	OFF	ON	OFF
3.5A	7.0A	ON	OFF	OFF
3.9A	7.8A	OFF	OFF	OFF

Notes: Due to motor inductance, the actual current in the coil may be smaller than the dynamic current setting, particularly under high speed condition.

Standstill current setting

SW4 is used for this purpose. OFF meaning that the standstill current is set to be half of the selected dynamic current, and ON meaning that standstill current is set to be the same as the selected dynamic current.

The current automatically reduced to 60% of the selected dynamic current one second after the last pulse. Theoretically, this will reduce motor heating to 36% (due to $P=I^2 \cdot R$) of the original value. If the application needs a different standstill current, please contact Leadshine.

9. Typical Connection

A complete stepping system should include stepping motor, stepping driver, power supply and controller (pulse generator). A typical connection is shown as figure 3.

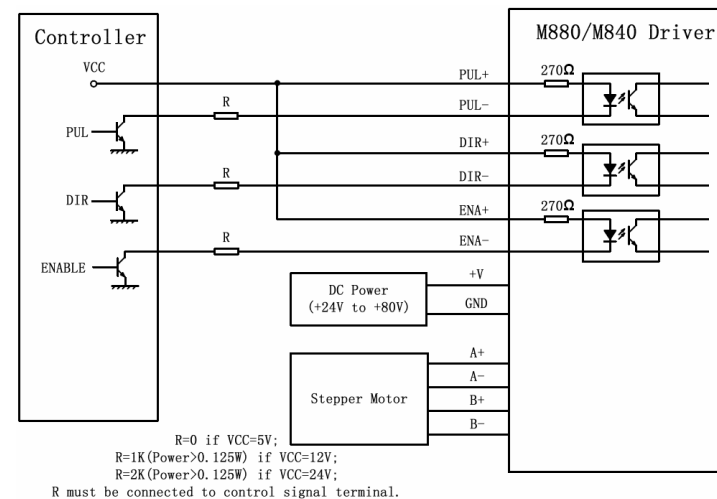

Figure 3: Typical connection