

# EM402 2-phase Digital Stepper Drive

## 20-40V, 0.07-2A, Sensorless Stall Detection, Pre-Matching Motor



- **Sensorless stall detection** eliminates cost of feedback devices and time of cable connection
- **Super-low** motor noise offers excellent quietness
- **User password protection** prevents others from copying your drive configurations
- **Anti-Resonance** optimizes torque and nulls mid-range instability
- Self-test and Auto-configuration technology offers optimum performance for different motors
- Multi-stepping allows a low resolution input to produce a higher microstep output for smoother system performance
- Options to set output current and microstep resolutions via DIP switch or software
- Command input of PUL/DIR, Microstep from 1 to 512
- Automatic idle-current reduction and reduction rate is software configurable
- Over-current, over-voltage, short-circuit protections besides sensorless stall detection
- Fault out prevents damages to your machines or the materials

### Descriptions

By implementing the latest motion control technologies, Leadshine's EM series DSP-based stepper drives deliver excellent performance not available before. Unique features of sensorless stall detection, extra smoothness and excellent high speed performance make EM stepper drives deliver servo-like performance at the cost of stepper drives. They are capable of delivering high performance without damages to your machines or the materials. Leadshine EM series stepper drives are able to drive 2-phase or 3-phase stepper motors from NEMA8 to NEMA23

### Applications

EM402 stepper drives are suitable for driving a wide range of stepper motors, from NEMA frame size 8 to 23. Typical applications include CNC routers, laser cutters, laser markers, medical equipments, X-Y tables, measurement equipments, etc.

## Specifications

### Electrical Specifications

Parameter	Min	Typical	Max	Unit
Input Voltage	20	24	40	VDC
Pulse Input Frequency	0	-	50	kHz
Logic Signal Current	7	10	16	mA
Isolation Resistance	500	-	-	MΩ

### Operating Environment

<b>Cooling</b>	Natural Cooling or Forced cooling	
<b>Operating Environment</b>	Environment	Avoid dust, oil fog and corrosive gases
	Storage Temperature	-20°C – 65°C (-4°F – 149°F)
	Ambient Temperature	0°C – 50°C (32°F – 122°F)
	Humidity	40%RH – 90%RH
	Operating Temperature (Heat Sink)	70°C (158°F) Max
	Vibration	10-55Hz, 0.15mm/s
<b>Storage Temperature</b>	-20°C – 65°C (-4°F – 149°F)	
<b>Weight</b>	107 g (3.77 oz)	

## Mechanical Specifications

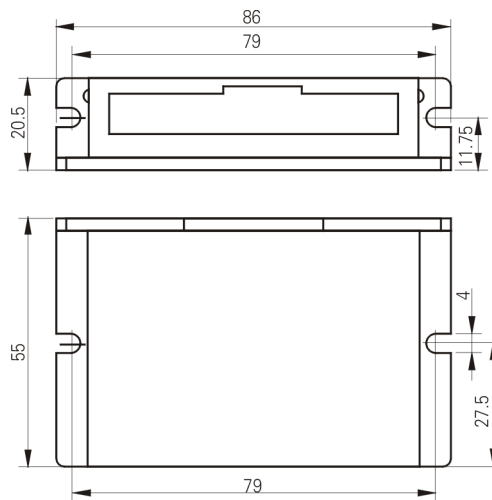

## Protection Indications

The green indicator turns on when power-up. When drive protection is activated, the red LED blinks periodicity to indicate the error type

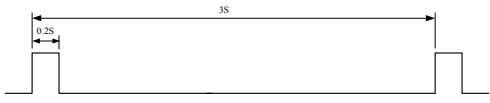
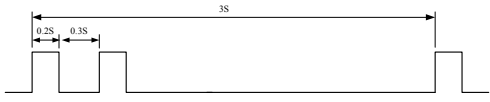
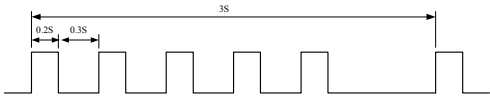
Priority	Time(s) of Blink	Sequence wave of RED LED	Description
1st	1		Over-current protection
2nd	2		Over-voltage protection
3rd	5		Motor Stall Protection

## Connectors and Pin Assignment

The EM402 has two connectors, connector for control signals connections, and connector for power and motor connections.

Control Signal Connector			
Pin	Name	I/O	Description
1	PUL+	I	<u>Pulse signal</u> : This input represents pulse signal, each rising or falling edge active (software configurable, see EM drives software operational manual for more detail); 4-5V when PUL-HIGH, 0-0.5V when PUL-LOW.
2	PUL-	I	For reliable response, pulse width should be longer than 10μs. Series connect resistors for current-limiting when +12V or +24V used. The same as DIR and ENA signal.
3	DIR+	I	<u>Direction Signal</u> : This signal has low/high voltage levels, representing two directions of motor rotation. For reliable motion response, DIR signal should be ahead of PUL signal by 5μs at least. 4-5V when DIR-HIGH, 0-0.5V when DIR-LOW. Please note that rotation direction is also related to motor-driver wiring match.
4	DIR-	I	Exchanging the connection of two wires for a coil to the driver will reverse motion direction. The direction polarity is software configurable,. See EM drives software operational manual for more detail.
5	ENA+	I	<u>Enable signal</u> : This signal is used for enabling/disabling the driver. In default, high level (NPN control signal) for enabling the driver and low level for disabling the driver. Usually left <b>UNCONNECTED (ENABLED)</b> .
6	ENA-	I	Please note that PNP and Differential control signals are on the contrary, namely Low level for enabling. The active level of ENA signal is software configurable. See EM drive's software manual for more detail.
7	FLT+	O	<u>Fault Signal</u> : OC output signal activated when over-voltage, over current and stall-error protection. This port can sink or source 20mA current at 24V. In default, the resistance between FLT+ and FLT- is low impedance in normal operation and become high impedance when EM402 goes into error. The active level of fault signal can be programmable. See EM drives software operational manual for more detail.
8	FLT-	O	

Power and Motor Connector			
Pin	Name	I/O	Description
1	A+	O	Motor Phase A+
2	A-	O	Motor Phase A-
3	B+	O	Motor Phase B+
4	B-	O	Motor Phase B-
5	+Vdc	I	Power Supply Input (Positive), 20-36VDC recommended, leaving rooms for voltage fluctuation and back-EMF.
6	GND	GND	Power Ground (Negative)

## RS232 Communication Port

It is used to configure the peak current, microstep, active level, current loop parameters and anti-resonance parameters. See EM driver's software operational manual for more information.

RS232 Communication Port			
Pin	Name	I/O	Description
1	NC	-	Not connected.
2	+5V	O	+5V power only for STU (Simple Tuning Unit).
3	TxD	O	RS232 transmit.
4	GND	GND	Ground.
5	RxD	I	RS232 receive.
6	NC	-	Not connected.

## DIP Switch Settings

### Dynamic Current

Peak	RMS	SW1	SW2
<b>Default</b>	<b>Default</b>	on	on
<b>0.7A</b>	<b>0.5A</b>	of	on
<b>1.5A</b>	<b>1.1A</b>	on	off
<b>2.2A</b>	<b>1.6A</b>	off	off

**Note:** Due to motor inductance, the actual current in the coil may be smaller than the dynamic current setting, particularly under high speed condition.

### Idle-Current

SW3 determines whether the idle current is reduced automatic or remains the same as the dynamic current setting.

	ON	OFF
SW3	The motor idle current reduces automatically when there is no pulse applied to EM402.	The motor idle current is the same as the dynamic current when there is no pulse applied to EM402.

### Auto-Configuration

Switch SW3 two times in two seconds to auto-configure the drive's current loop parameter. That is, OFF-ON-OFF or ON-OFF-ON. During Auto-configuration, motor parameters are identified and the EM drive's current loop parameters are calculated automatically. The motor shaft will vibrate a little during the process of Auto-configuration which takes about 1 to 3 seconds.

### Microstep Resolution

Steps/Revolution	SW4	SW5
Software Configured (Default 200)	on	on
400	off	on
800	on	off
1600	off	off

### Motor Selection and Pre-matching Leadshine Motor

Matching Motor	Connection	SW6	SW7	SW8	Description
35HS01	-	on	on	on	Select pre-matching Leadshine stepper motor. EM402 has been tuned for these motors.
39HS02	-	off	on	on	
42HS03	Parallel	on	off	on	
57HS04	Series	off	off	on	
Custom1	-	on	on	off	Select non-Leadshine motor. EM402 needs tuning either by Auto-configuration or the PC software.
Custom2	-	off	on	off	
Custom3	-	on	off	off	There are up to four custom positions for customer selection.
Custom4	-	off	off	off	

### Speed Torque Curve for Pre-matching Leadshine Motor

Stepper Motor: 35HS01

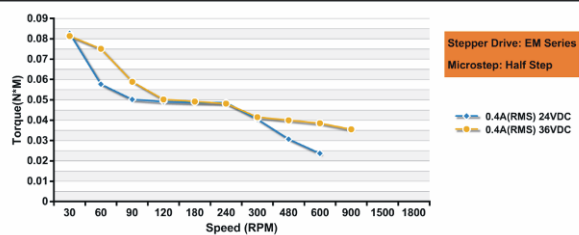

Stepper Motor: 39HS02

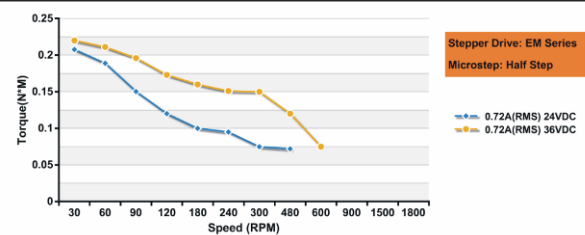

Stepper Motor: 42HS02

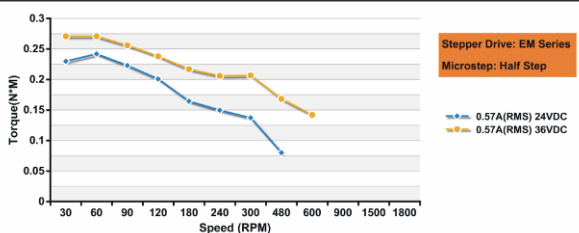

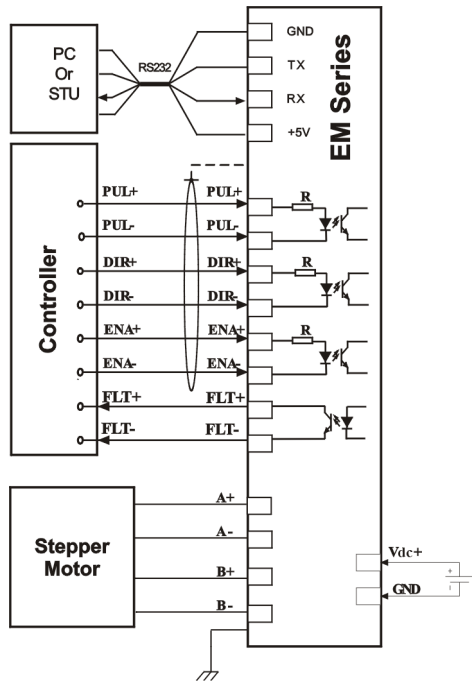
**Typical Connections**
**Differential Control Signal**

**NPN Control Signal**
